



High energy photon production in bent crystals: the latest measurements.

**S. Hasan¹ on behalf of the INSURAD Collaboration:
A.G. Afonin⁷, E. Bagli², S. Baricordi², A. Berra¹, D. Bolognini¹, Yu. A. Chesnokov⁷,
P. N. Chirkov⁷, P. Dalpiaz², G. Della Mea^{3,4}, D. De Salvador^{4,5}, V. Guidi², V. A.
Maishev⁷, A. Mazzolari², M. Prest¹, E. Vallazza⁶, D. Vincenzi², I. A. Yazynin⁷**

¹ Università degli Studi dell'Insubria, Via Valleggio 11, 22100 Como, Italy and INFN Sezione di Milano Bicocca, Piazza della Scienza 3, 20126 Milano, Italy.

² INFN Sezione di Ferrara and Dipartimento di Fisica, Università di Ferrara, Via Saragat 1, 44100 Ferrara, Italy

³ Dipartimento di Ingegneria dei Materiali e Tecnologie Industriali, Università di Trento, Via Mesiano 77, 38050 Trento, Italy

⁴ Dipartimento di Fisica Università di Padova, Via 8 Febbraio 1848 2, 35121 Padova, Italy

⁵ INFN Laboratori Nazionali di Legnaro, Viale Università 2, 35020 Legnaro (PD), Italy

⁶ INFN Sezione di Trieste, Via Valerio 2, 34127 Trieste, Italy

⁷ Institute of High Energy Physics, Moscow Region, RU-142284 Protvino. Russia



Why

- Measure **radiation** from **bent crystals**?

2009 beam test to measure the radiation emission (positrons of 120GeV)

- How we measure **deflection** and **radiation**
- **Results:**
 - **Channeling and Volume Reflection**
 - **Comparison with theory**

Going beyond

- Multi crystals and axial effects → **to increase the intensity**

Why measure radiation from bent crystals?

 Bent crystals are devices that can be used for many applications; the most important are: beam collimation, beam extraction, beam splitting

 At the moment they are addressed to hadron machines (e.g. LHC collimation)

 A future application to electron-positron machines should take into account the radiation issue

 The high amount of energy loss inside a bent crystal can be used to perform collimation in an electron-positron machine

 The electromagnetic cascade inside a bent crystal can be exploited to design a high intensity electron-positron source

 Bent crystals can be used as a high intensity photon source dedicated to nuclear physics studies or detector tests such as calibration

How we measure the deflection properties:

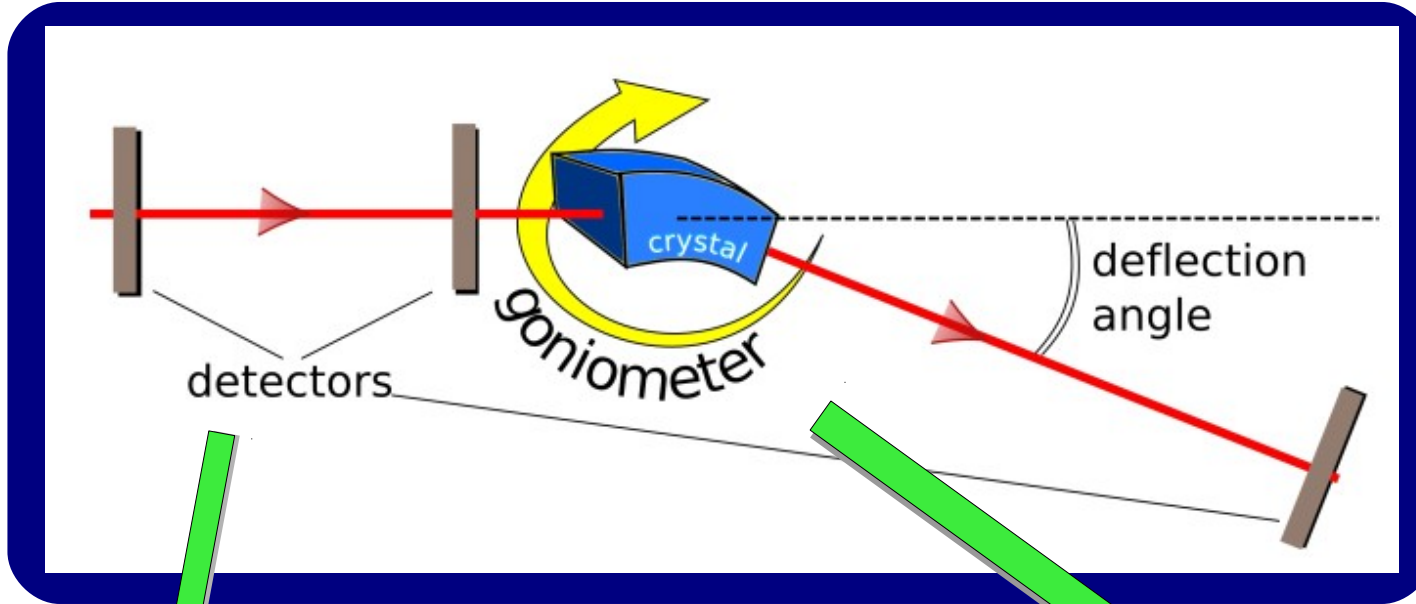

Tracking system

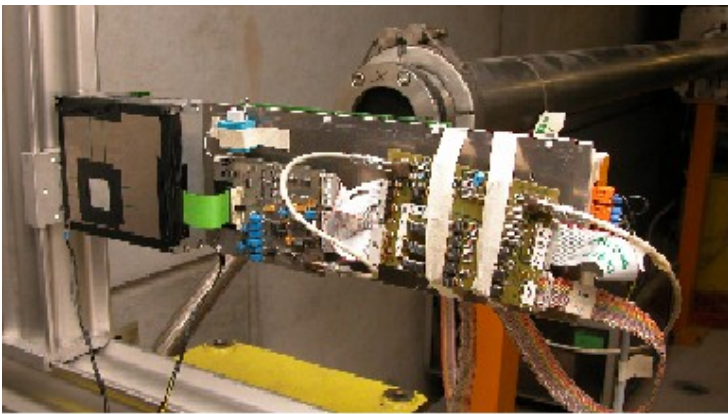

Double sided silicon microstrip detector
Physical strip pitch: 25um
Resolution: 6um

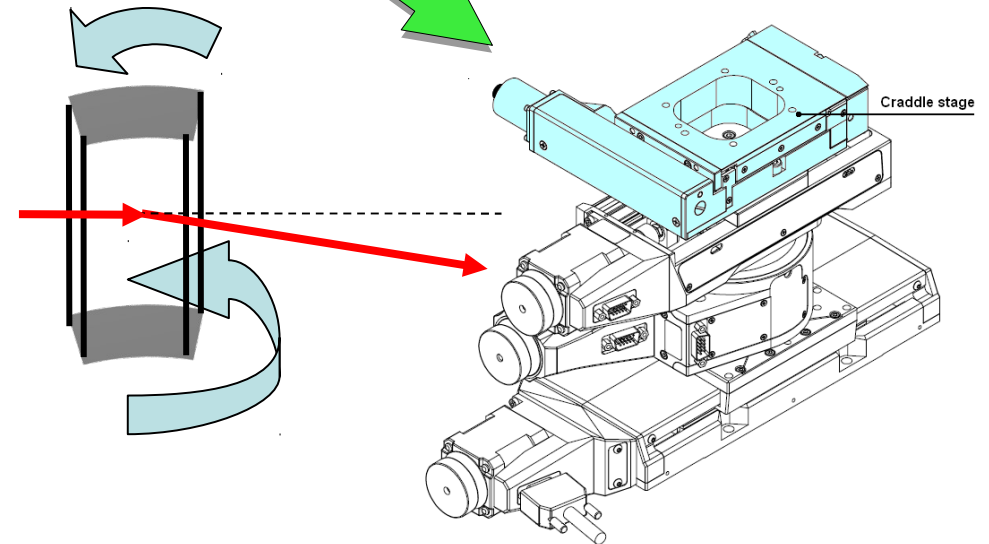

High resolution goniometer (res: ~1urad)
2 rotational and 2 linear movements

Deflection measurements

Misaligned crystal →
Amorphous behaviour

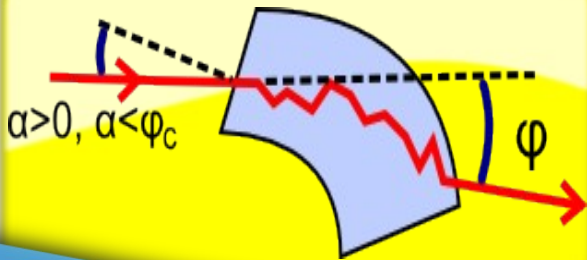
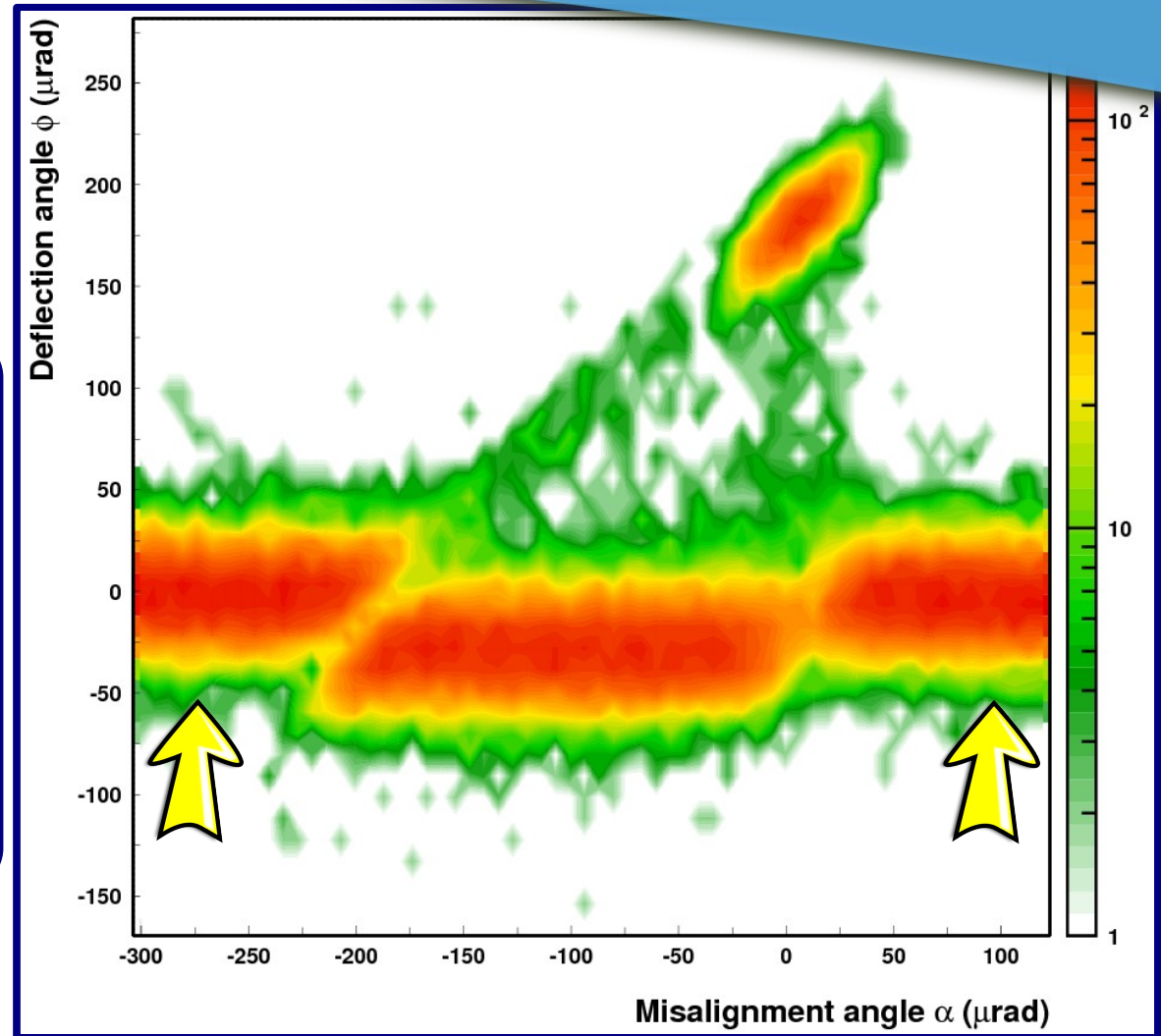
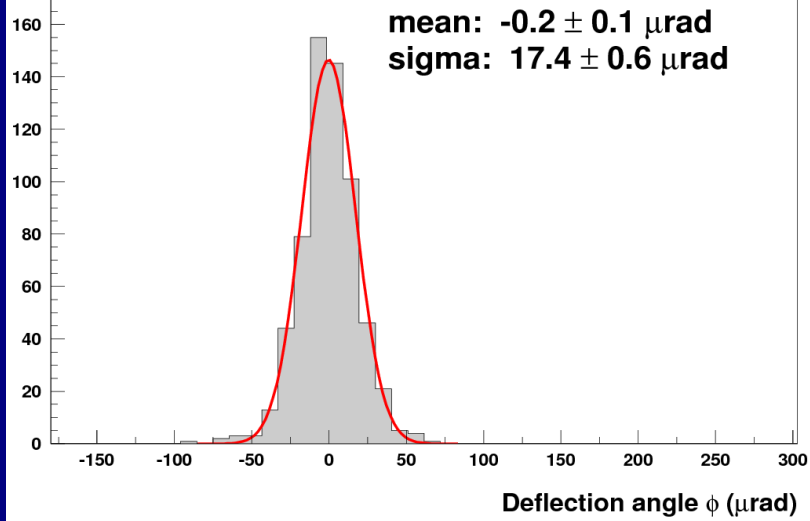

2mm silicon strip crystal aligned along the (110) plane

Deflection measurements

Perfect alignment → channeling

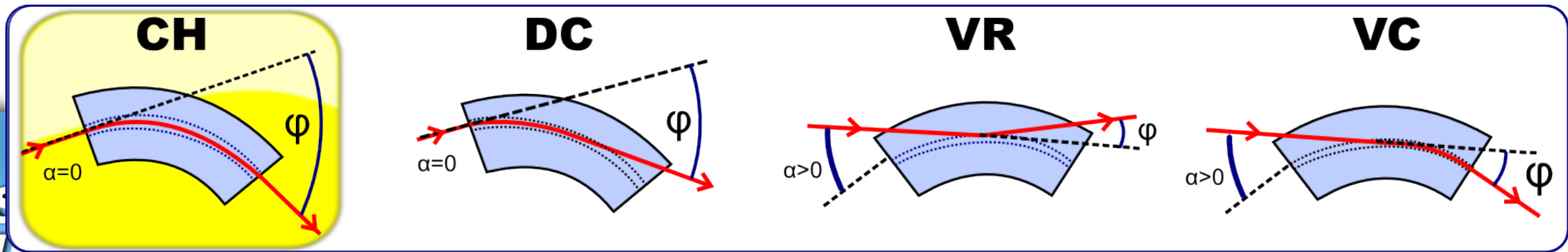
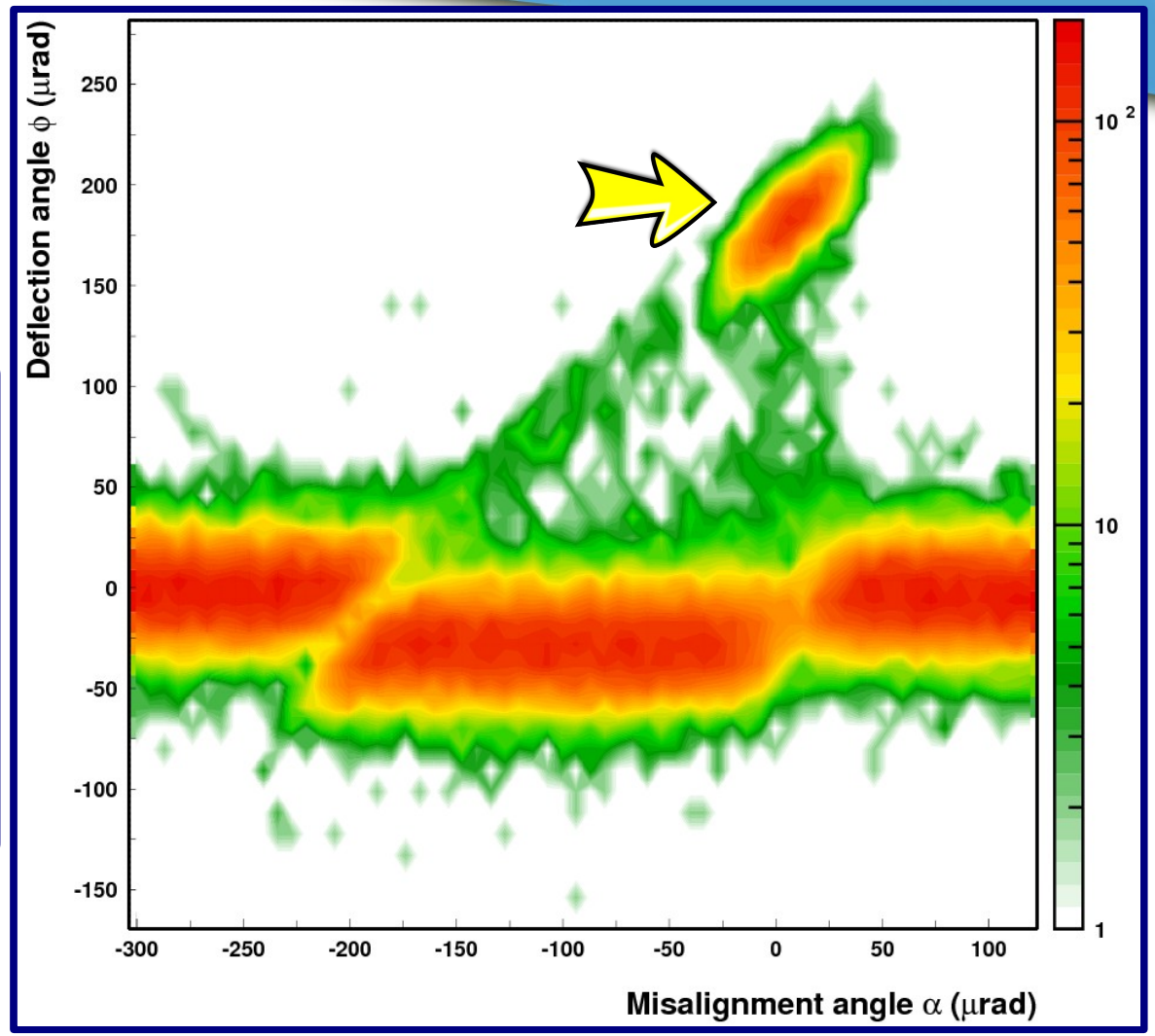
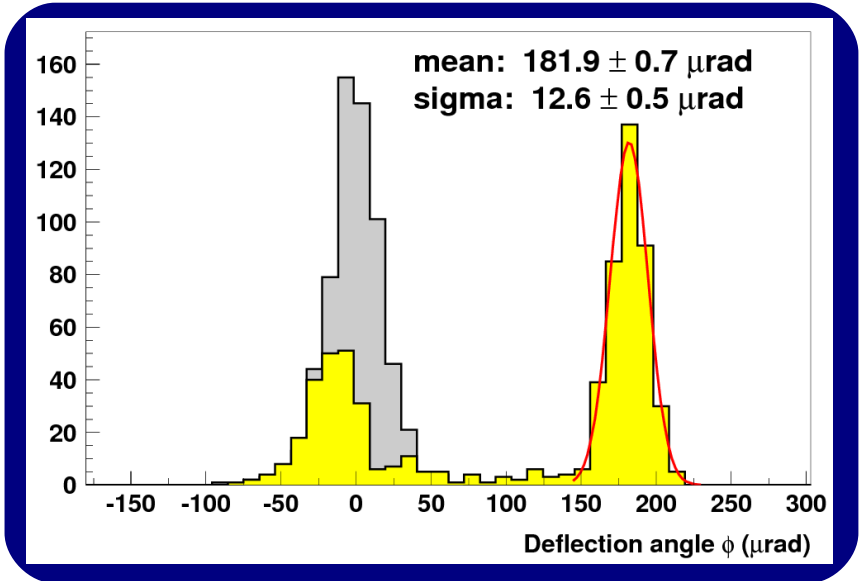

Deflection measurements

Perfect alignment →
dechanneling

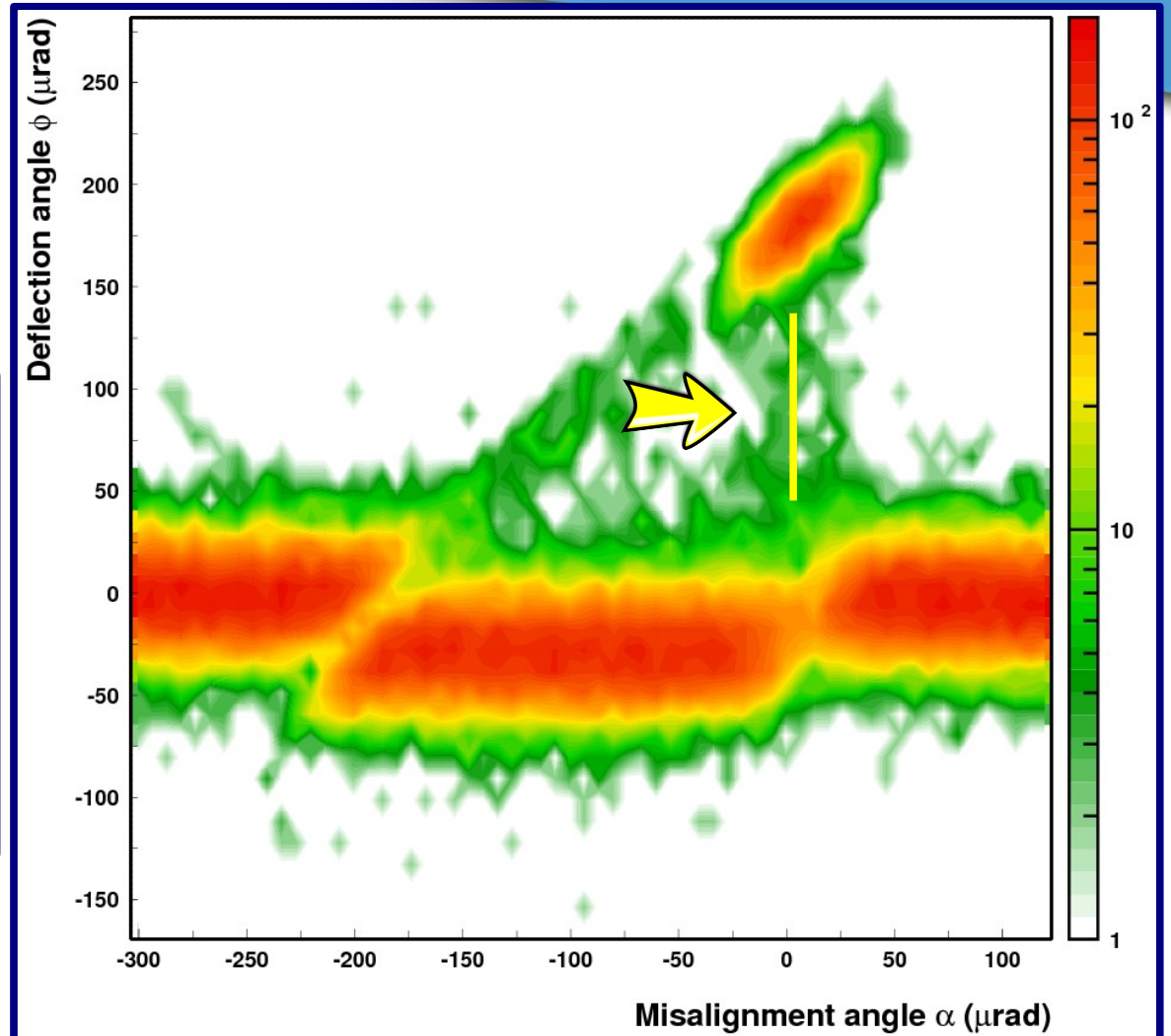
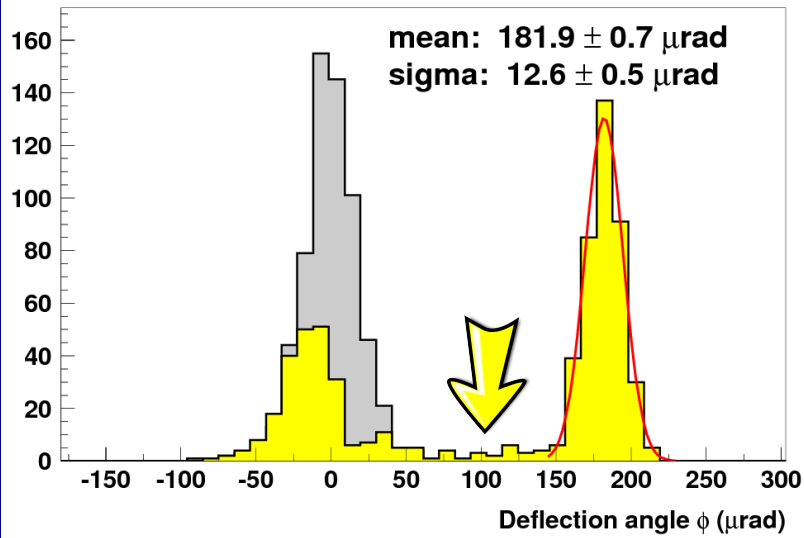

CH

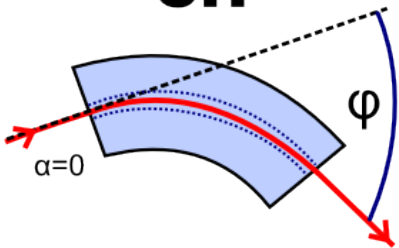

DC

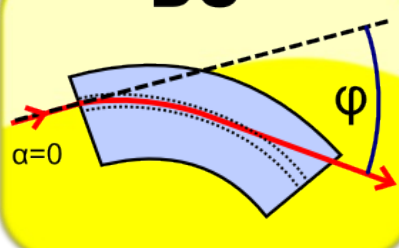

VR

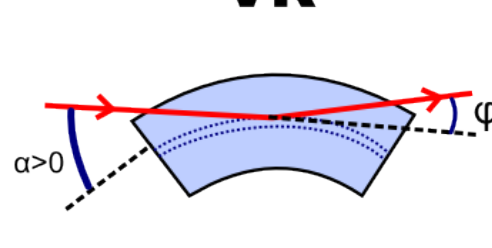

VC

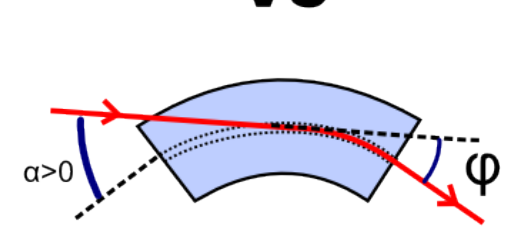

Deflection measurements

Tangency inside crystal
→ Volume Reflection

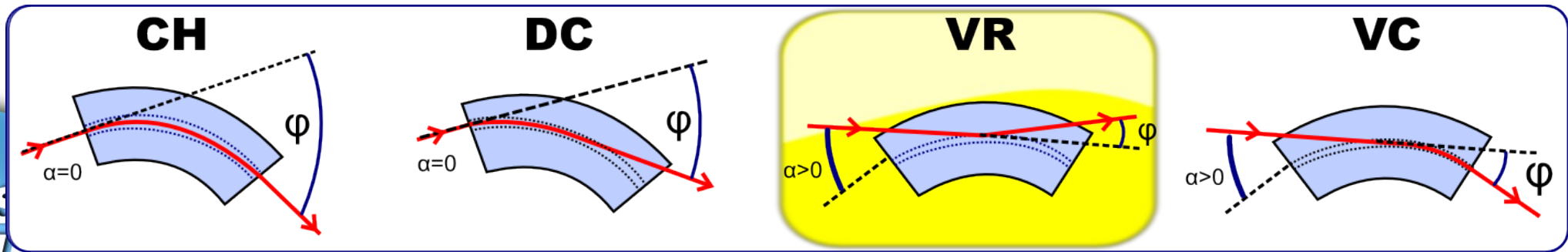
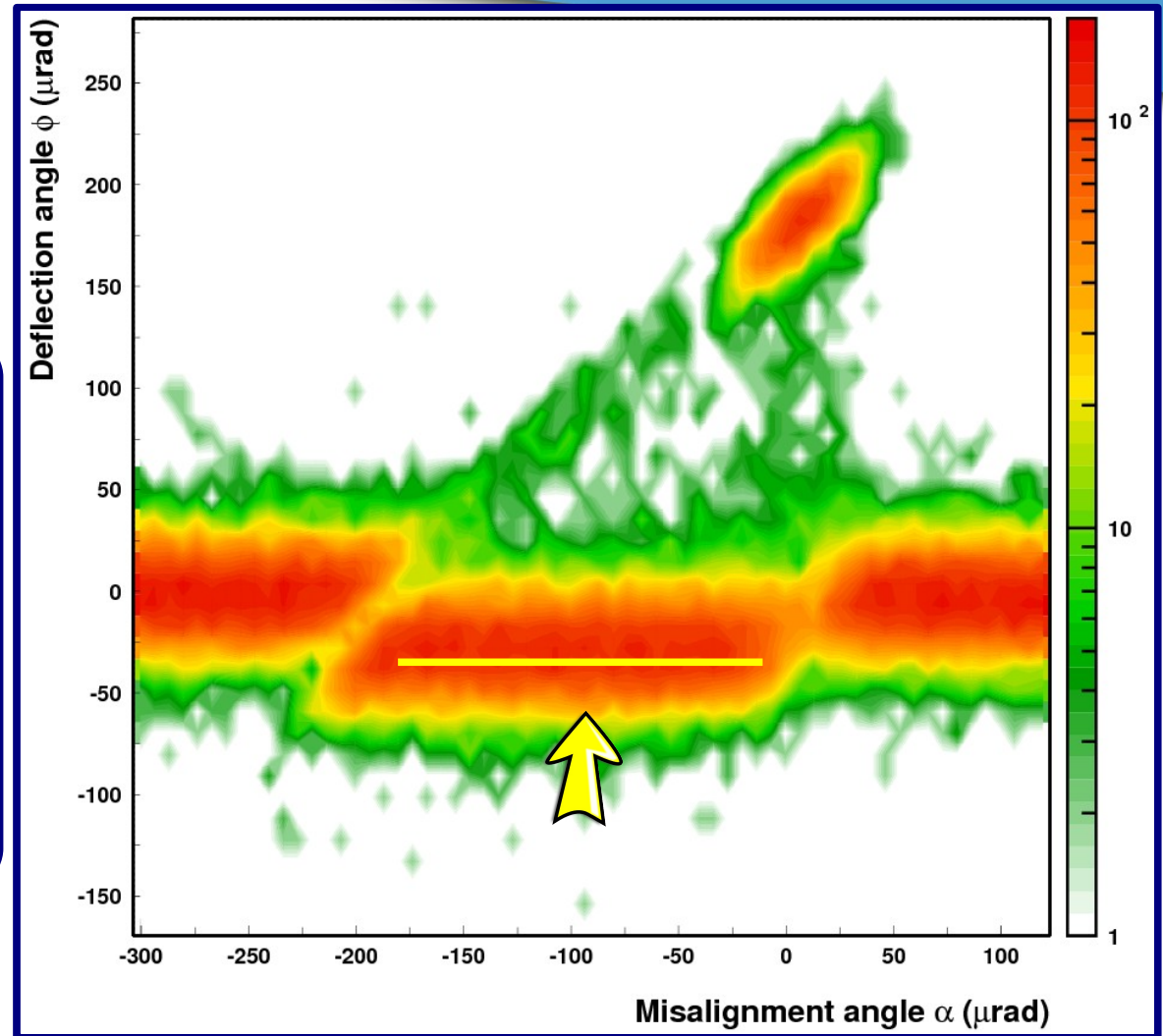
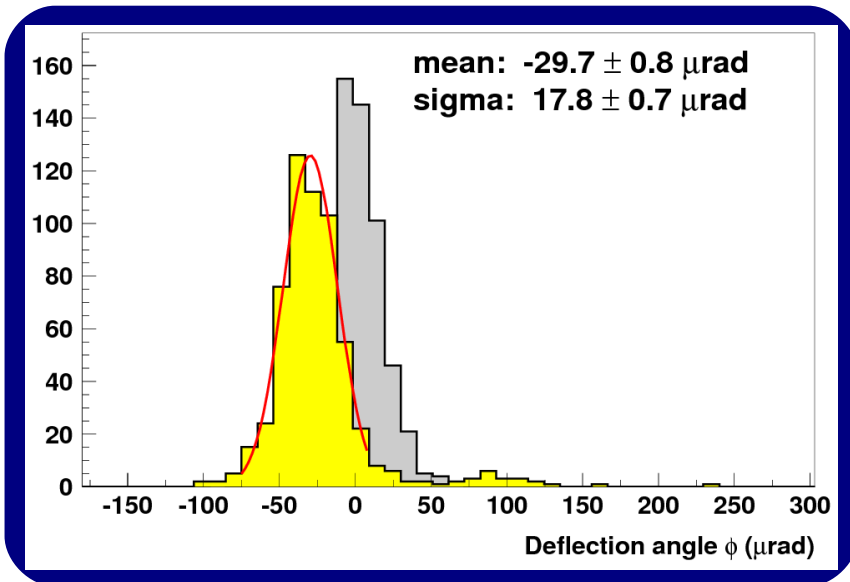

Deflection measurements

Tangency inside crystal
→ Volume Capture

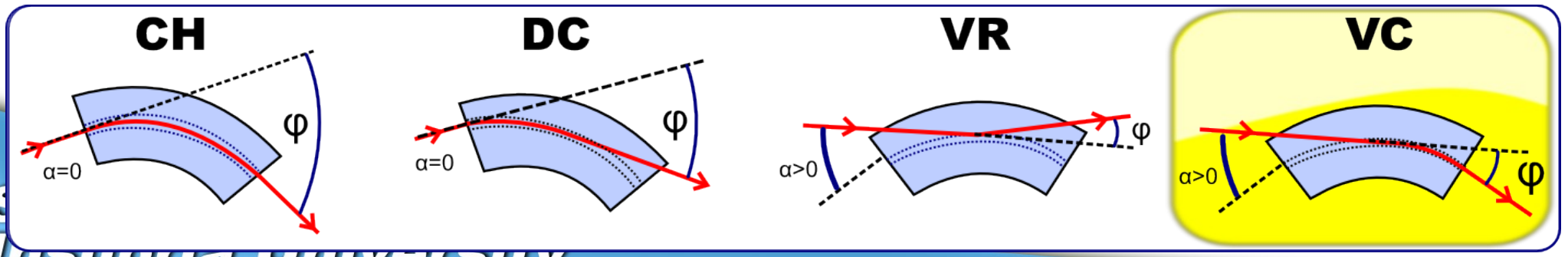
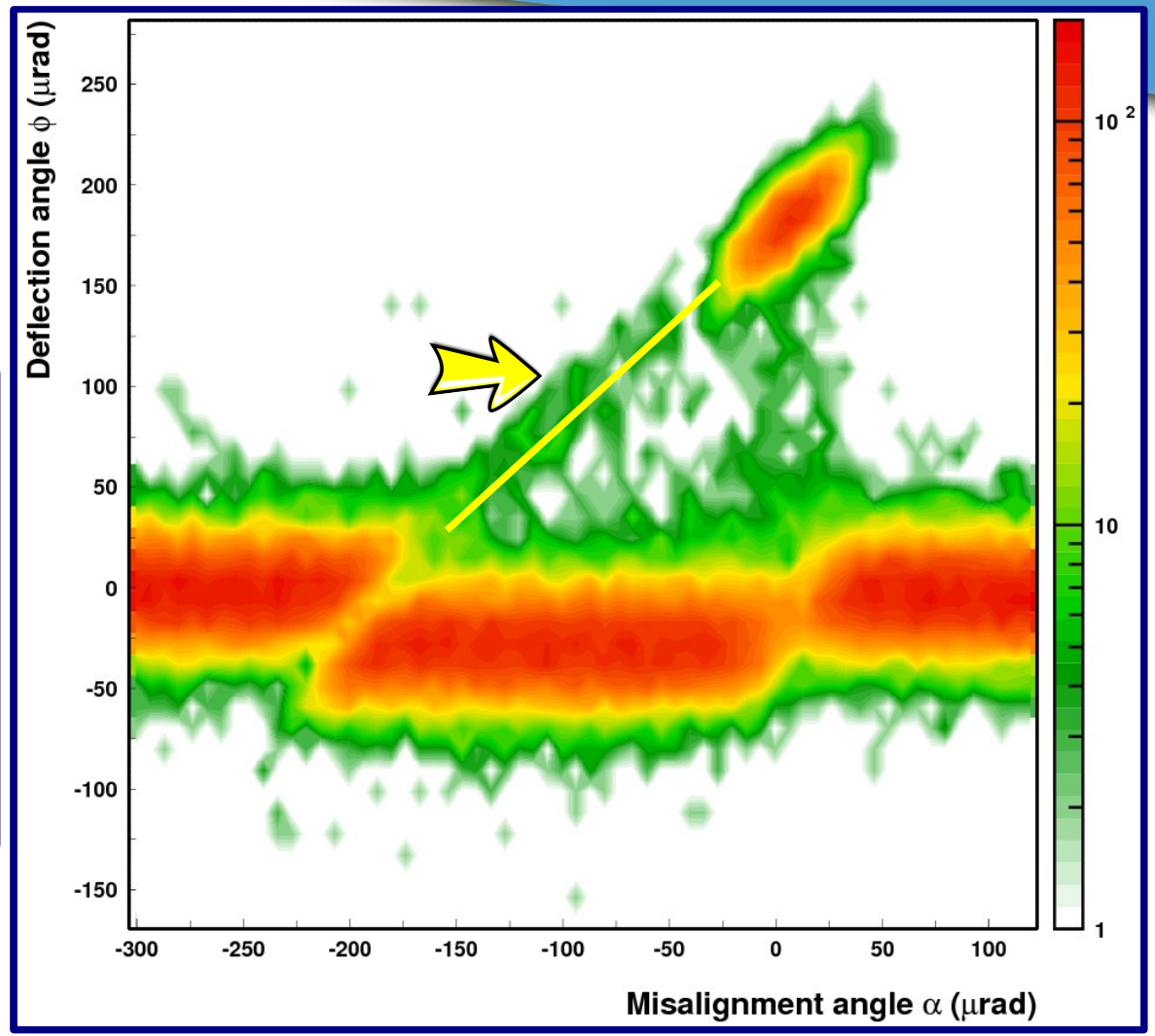
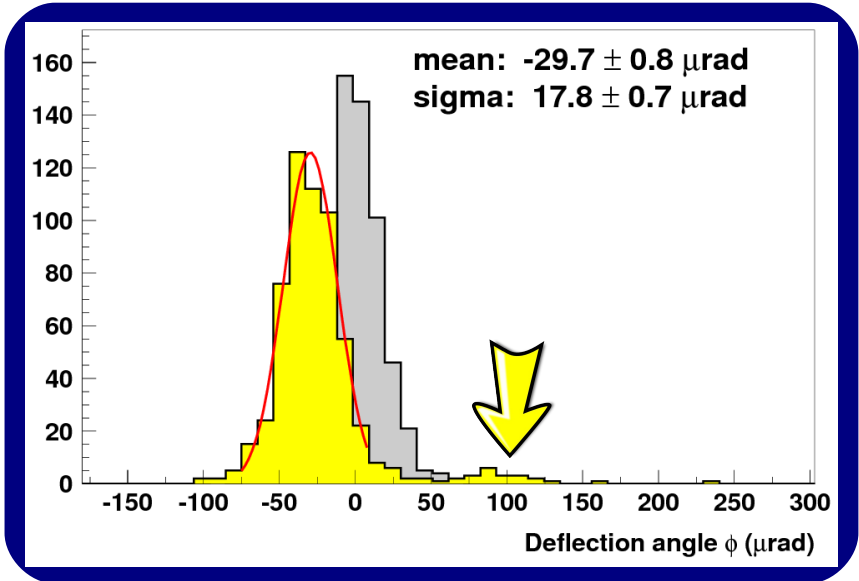

High energy photons from bent crystals

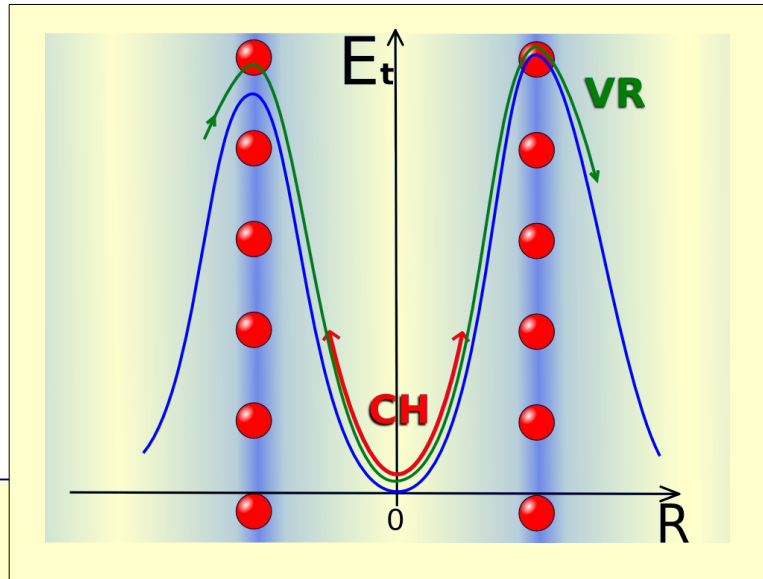

Volume reflection

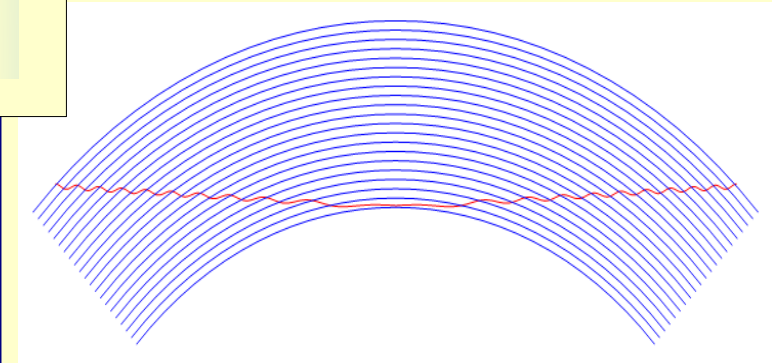

particles slightly over barrier cross the crystalline plane with an angle which varies along the trajectory

Channeling

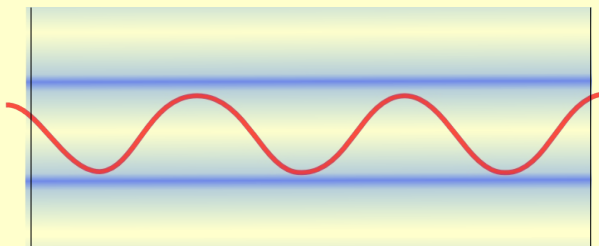

particles confined in the interplanar potential that perform quasi harmonic oscillations emitting radiation

Let's measure it!

September 2009, H4 beam line (CERN, SPS), 120 GeV positrons

deflection

radiation

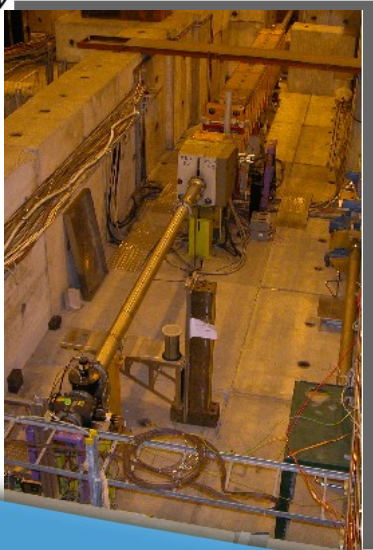
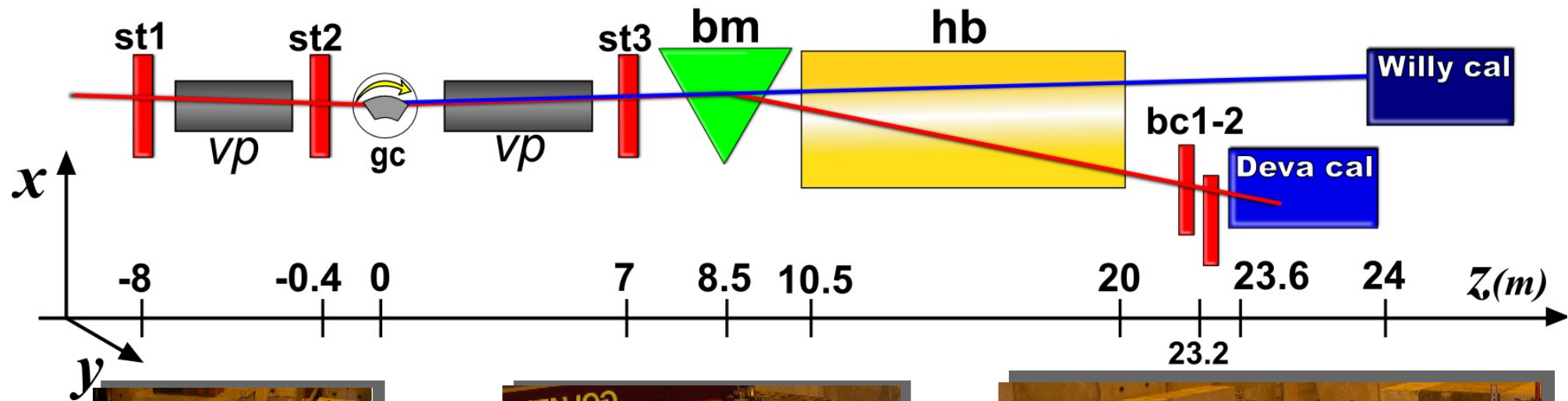

Let's measure it

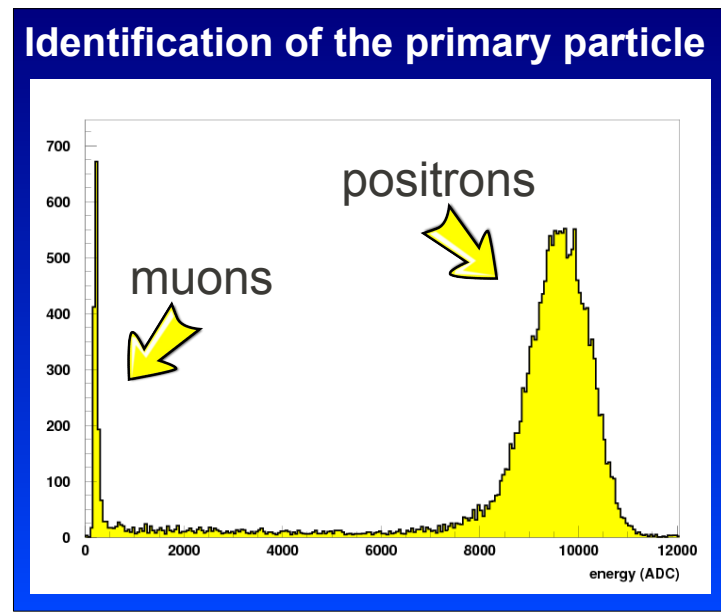
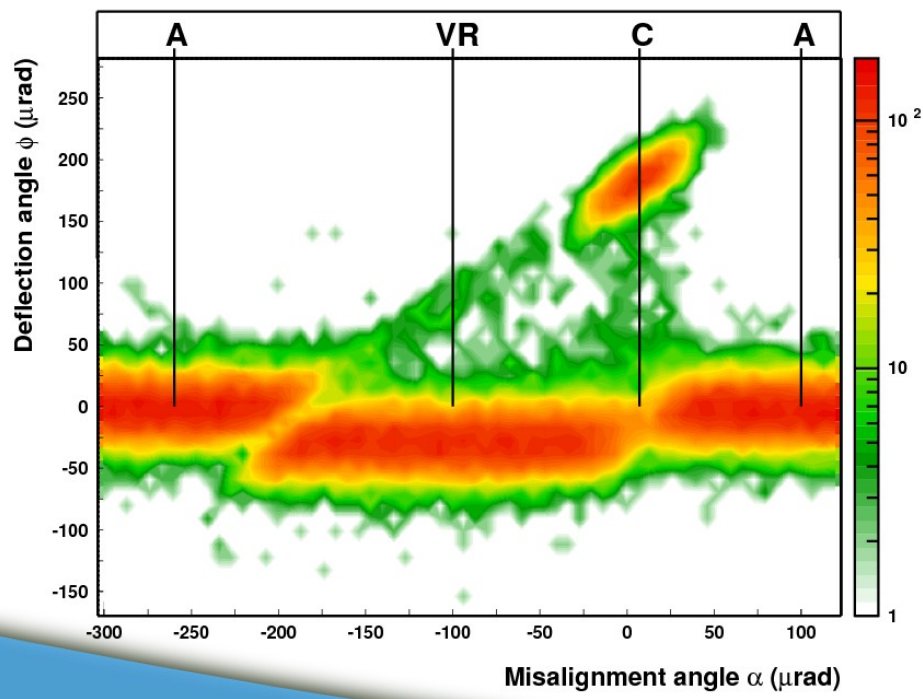

Let's measure it

deflection

radiation

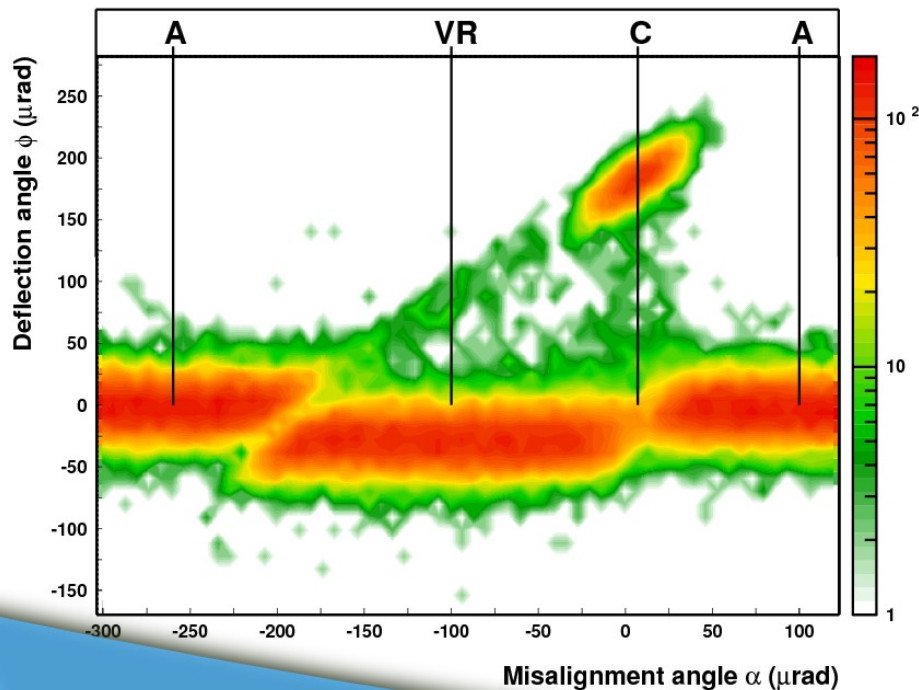
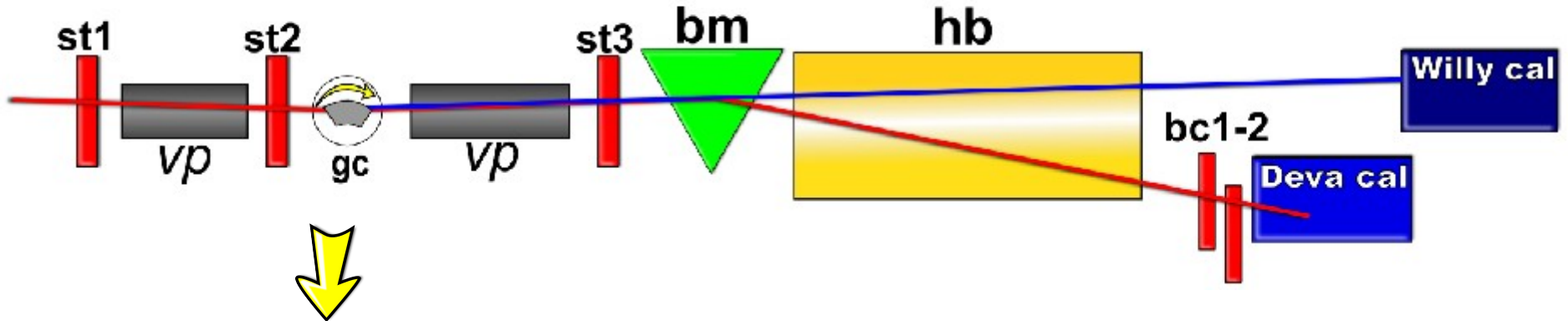

Spectrometer angular distribution

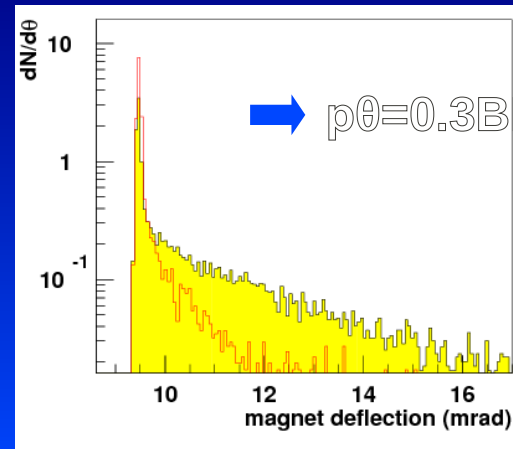

Spectral distribution

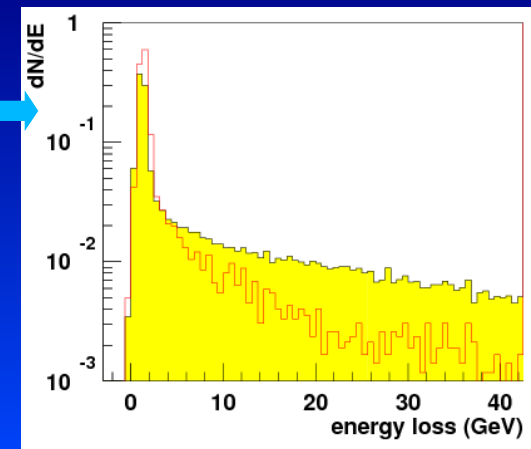

Let's measure it

deflection

radiation

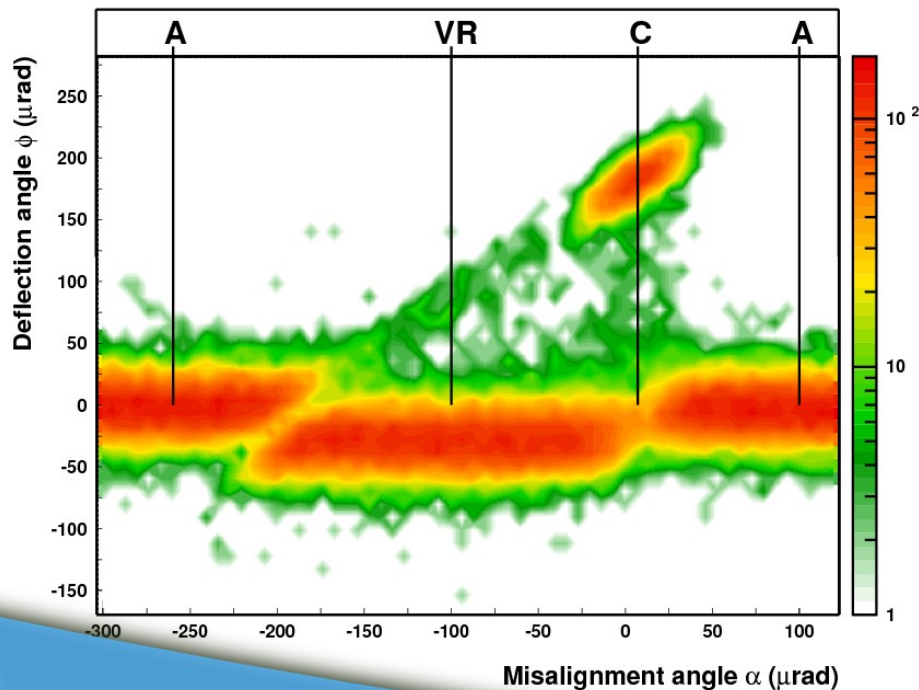
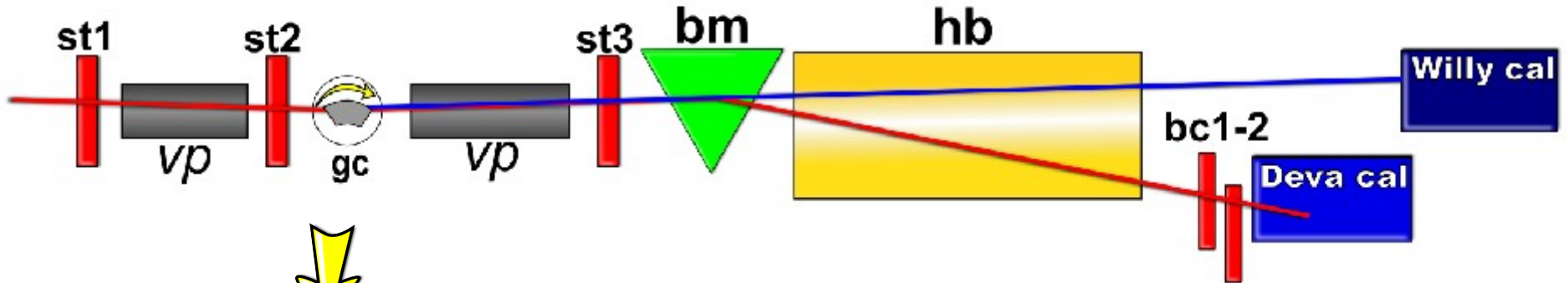

Comparison calorimeter-spectrometer

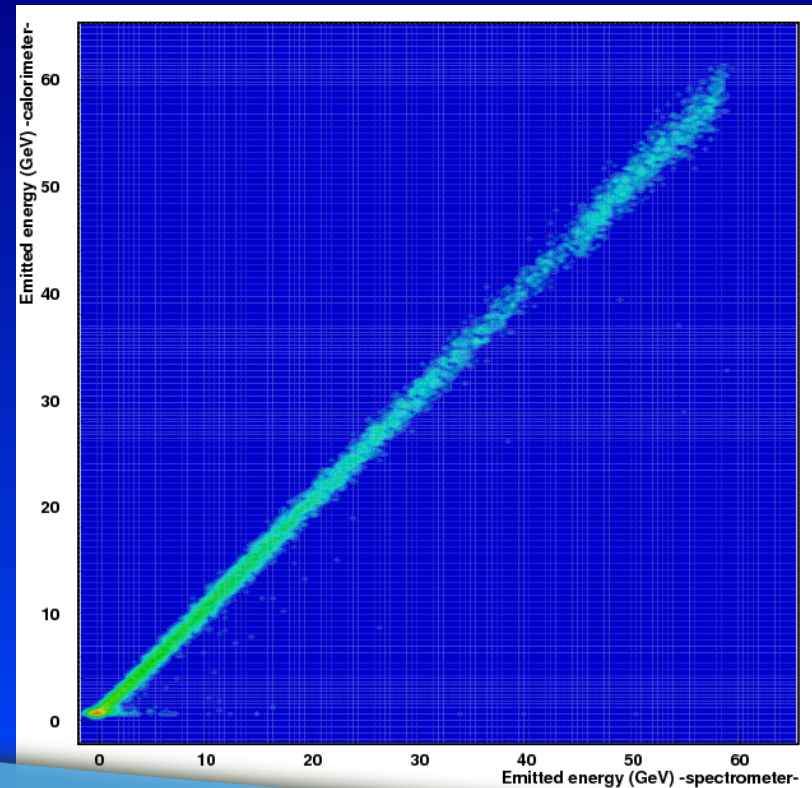

Let's measure it

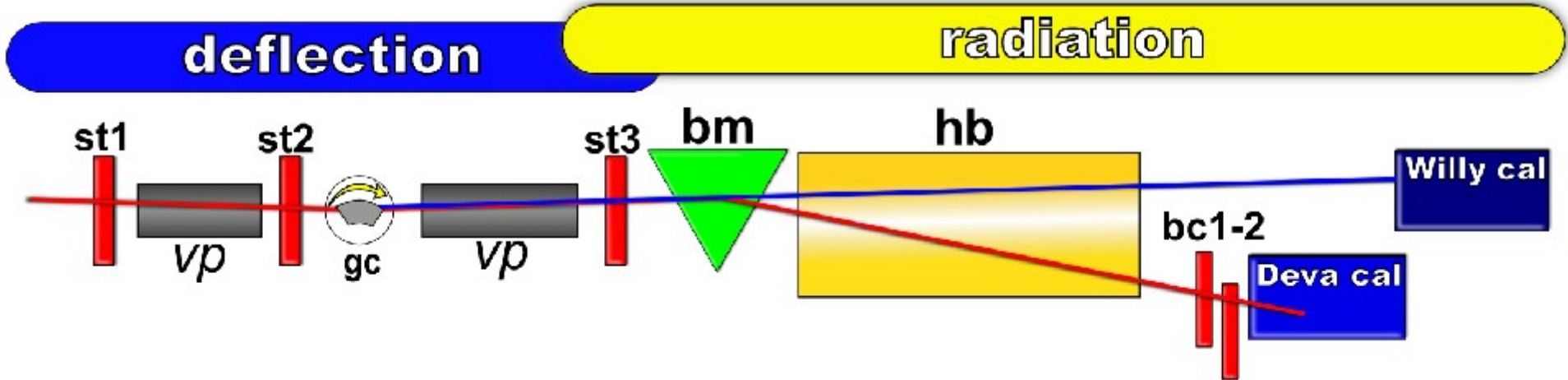

It is possible to "select" an effect and measure its "radiation" properties:

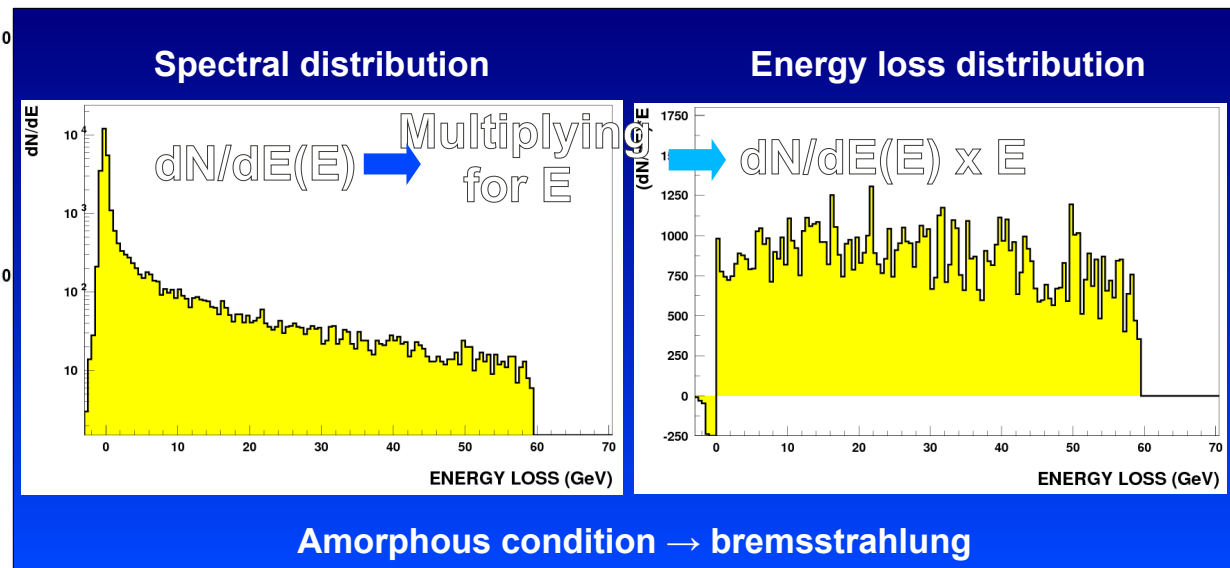
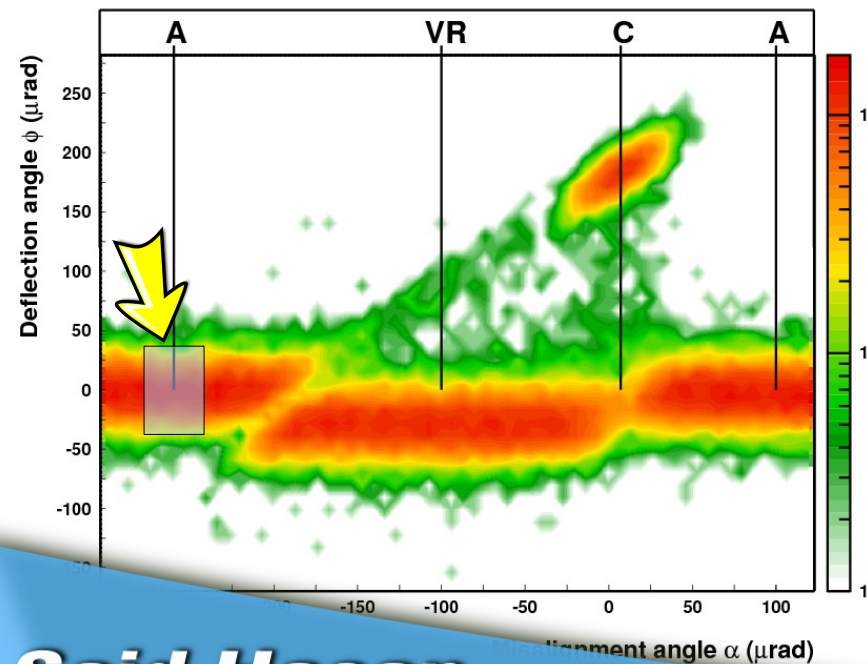

Amorphous condition \rightarrow bremsstrahlung

Channeling

Strip crystal:

2mm of silicon along the beam
~5m bending radius

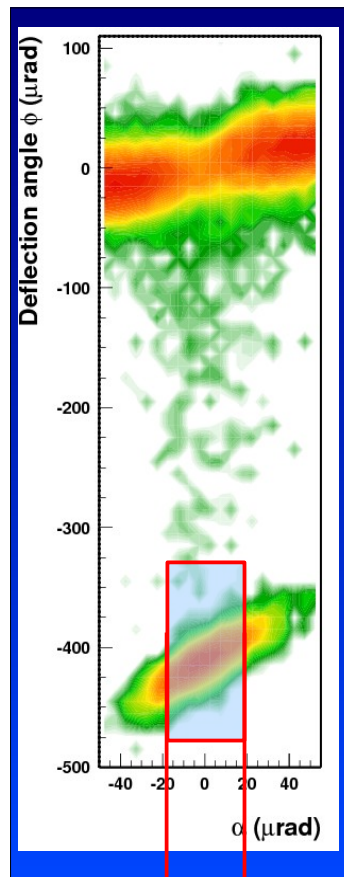
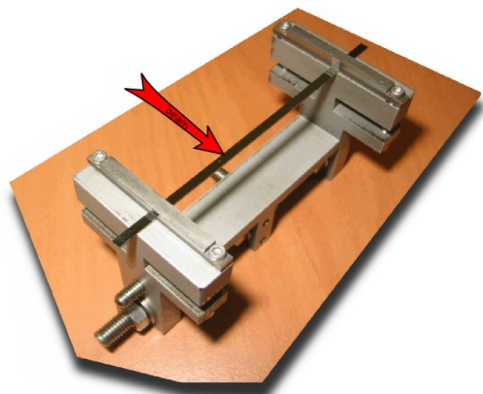

Selected region:
Channeled particle
 $-9 < \alpha < 9 \text{ urad}$

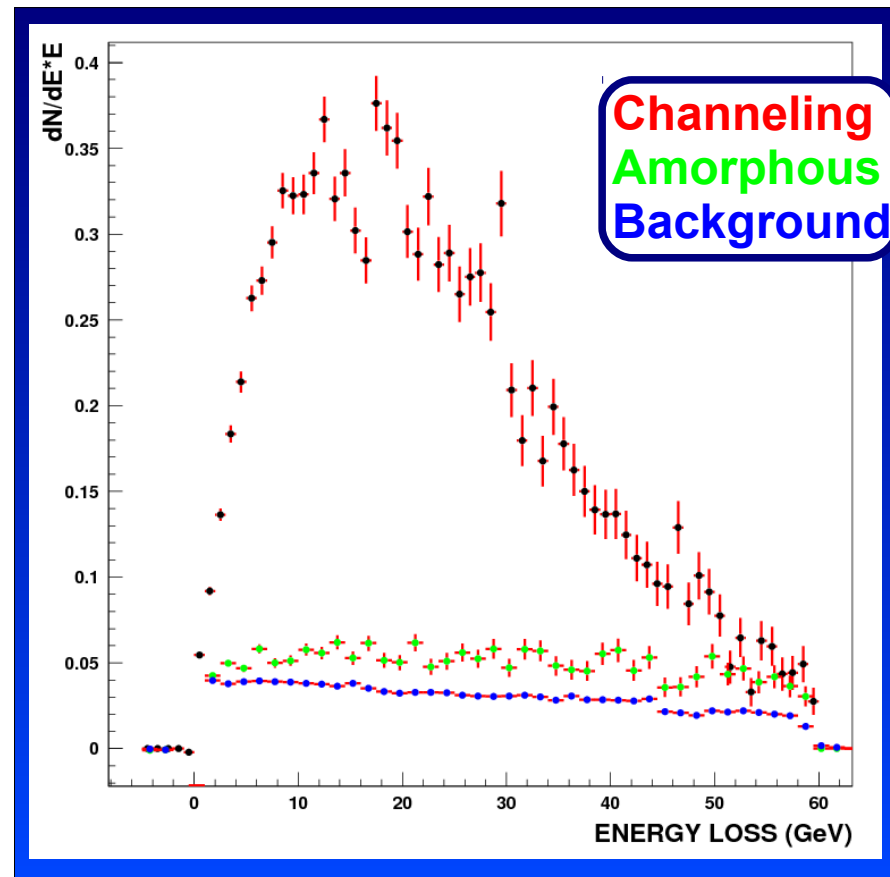

Channeling
Amorphous
Background

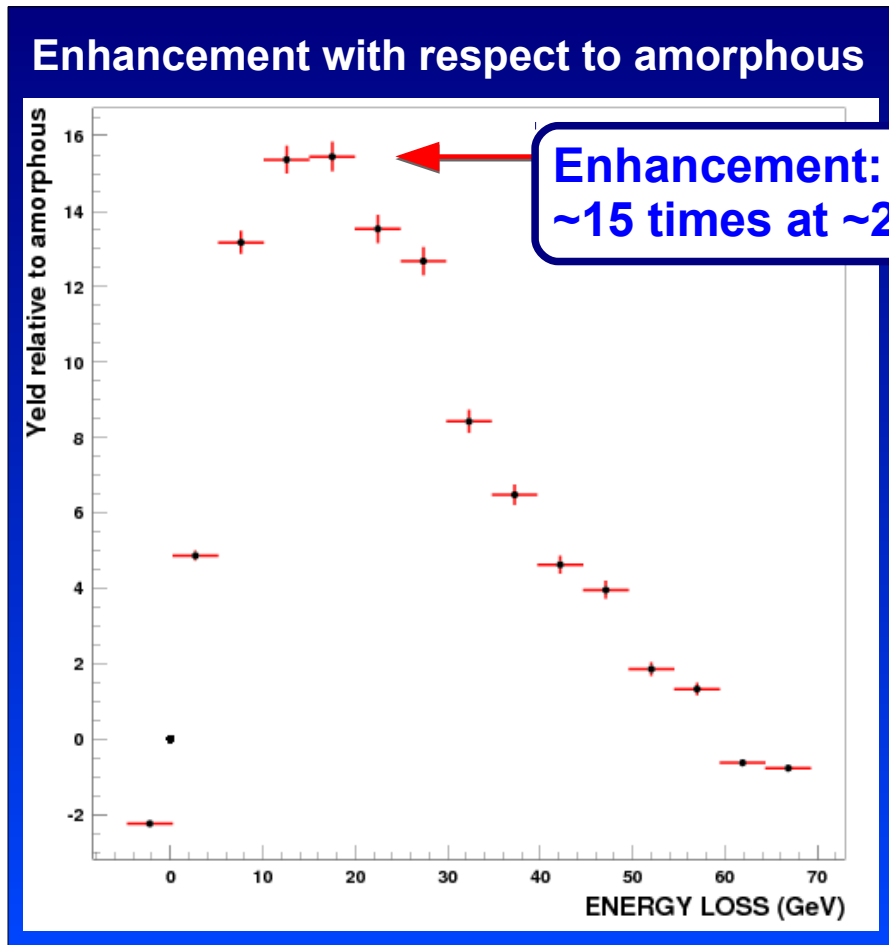
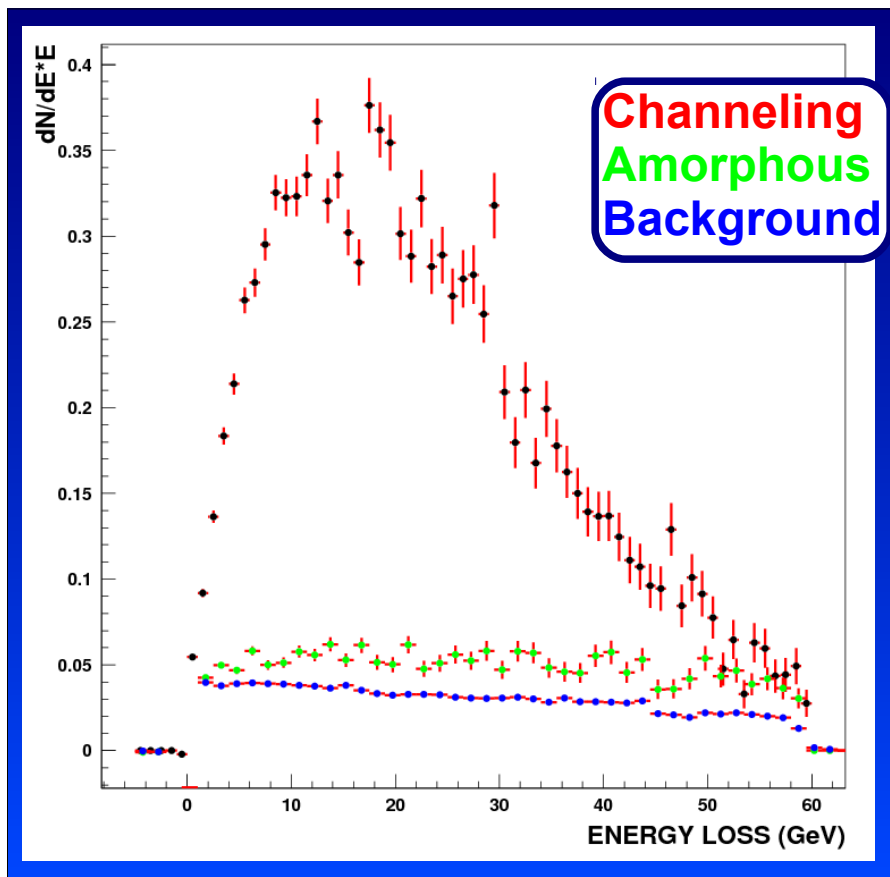

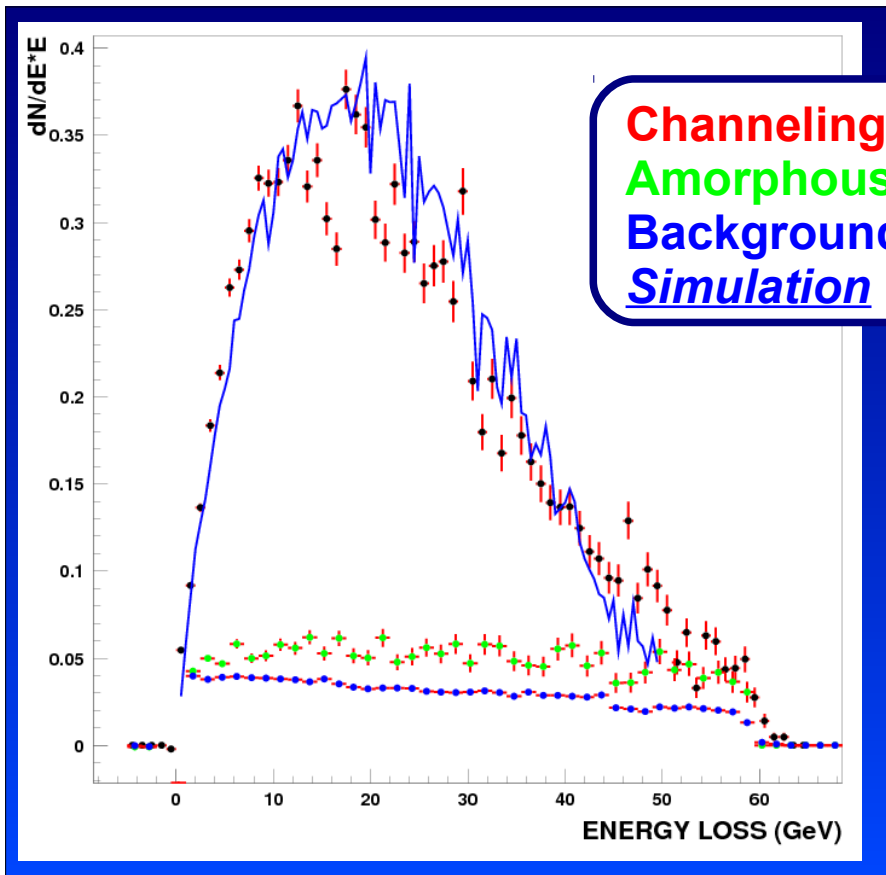

Average energy loss: $\sim 11.7\text{GeV}$

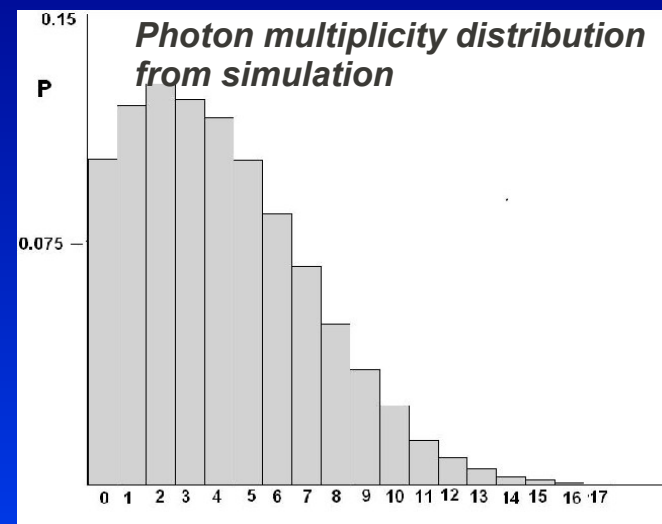

Average photons multiplicity: ~ 4

Channeling

The effect of bending is negligible:

Strip crystal:

2mm of silicon along the beam
~11m bending radius

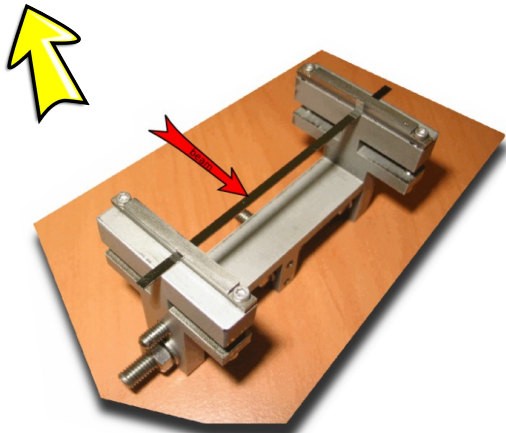

The same crystal with smaller bending

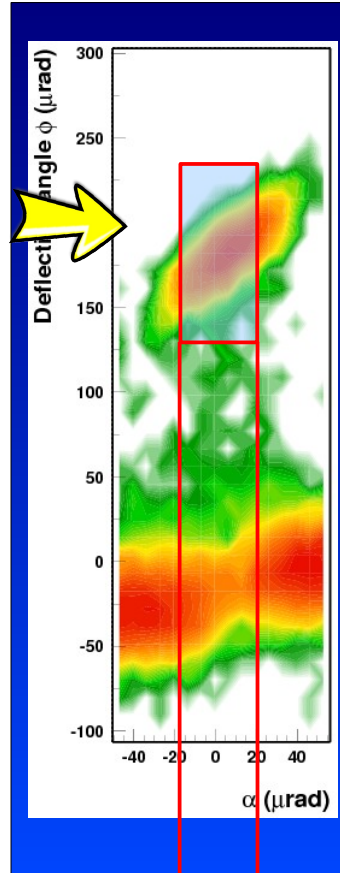

Selected region:
Channeled particle
 $-9 < \alpha < 9 \text{ urad}$

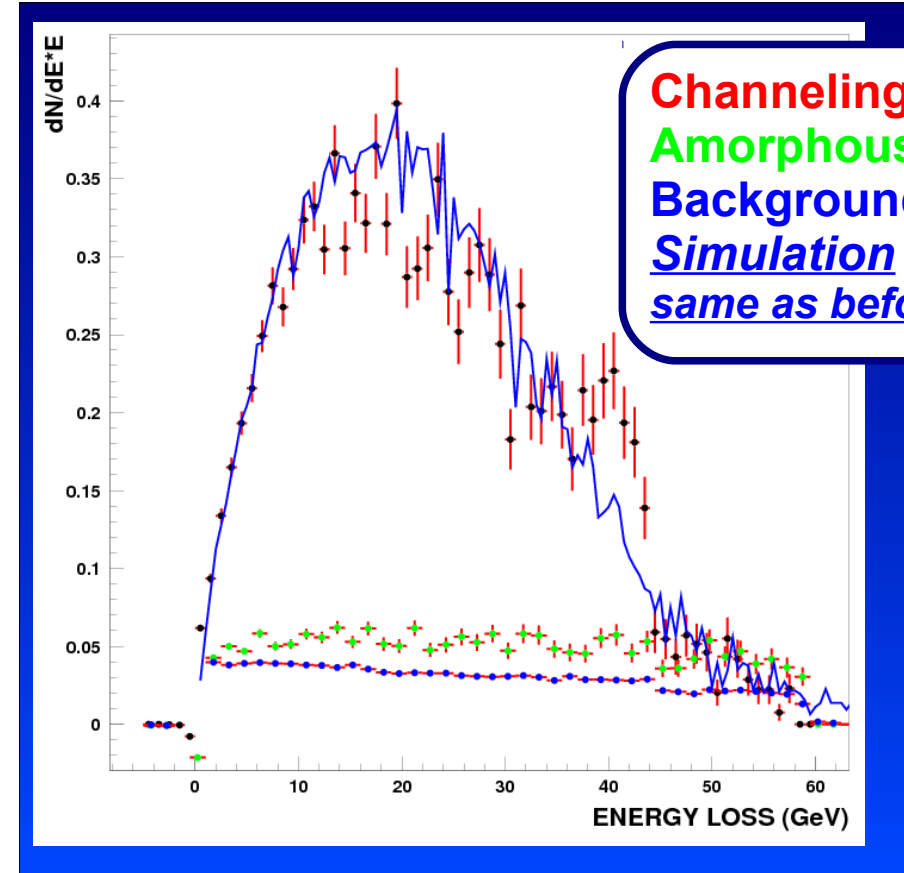

Volume Reflection (present only in bent crystal)

Strip crystal:

2mm of silicon along the beam
~11m bending radius

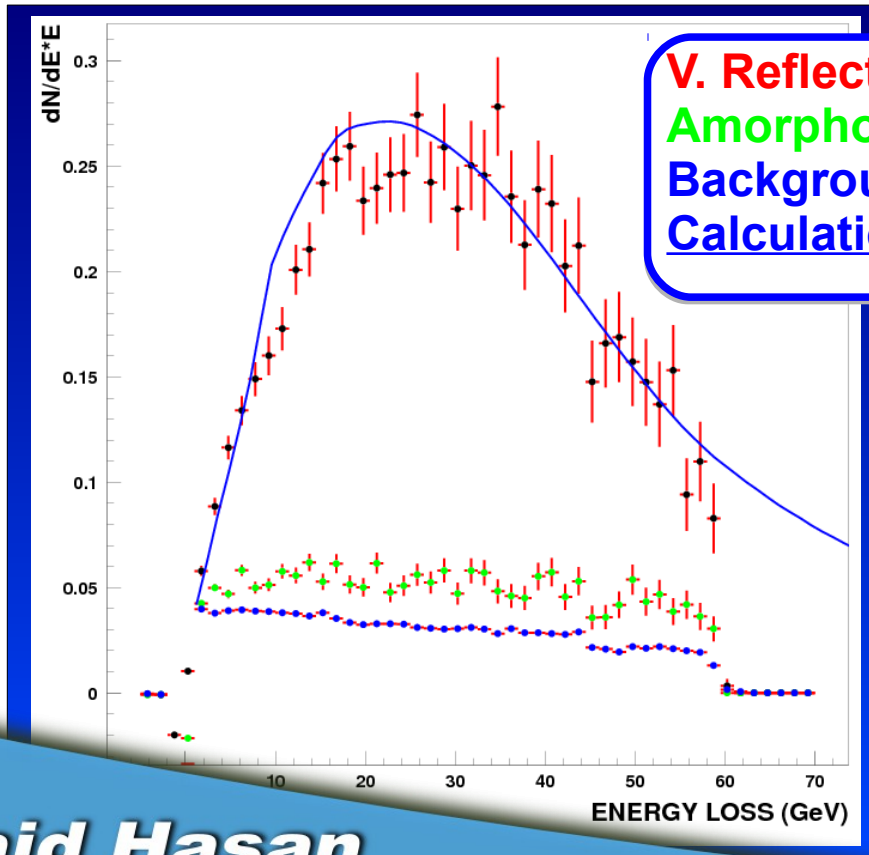
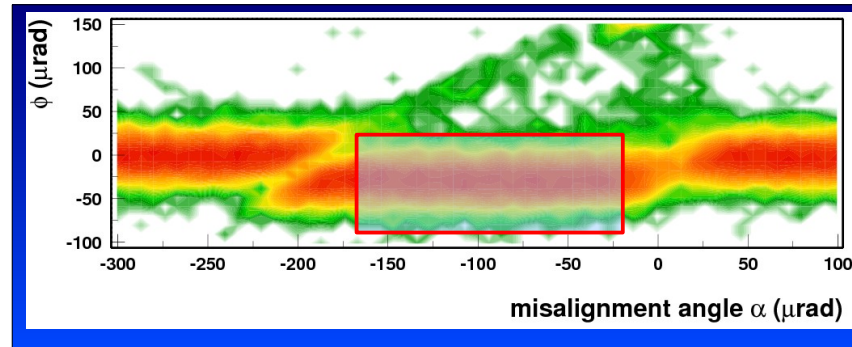
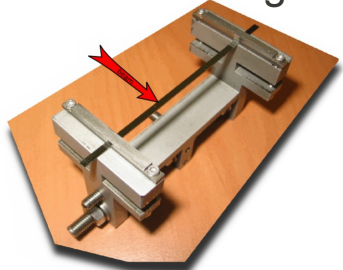

V. Reflection
Amorphous
Background
Calculation

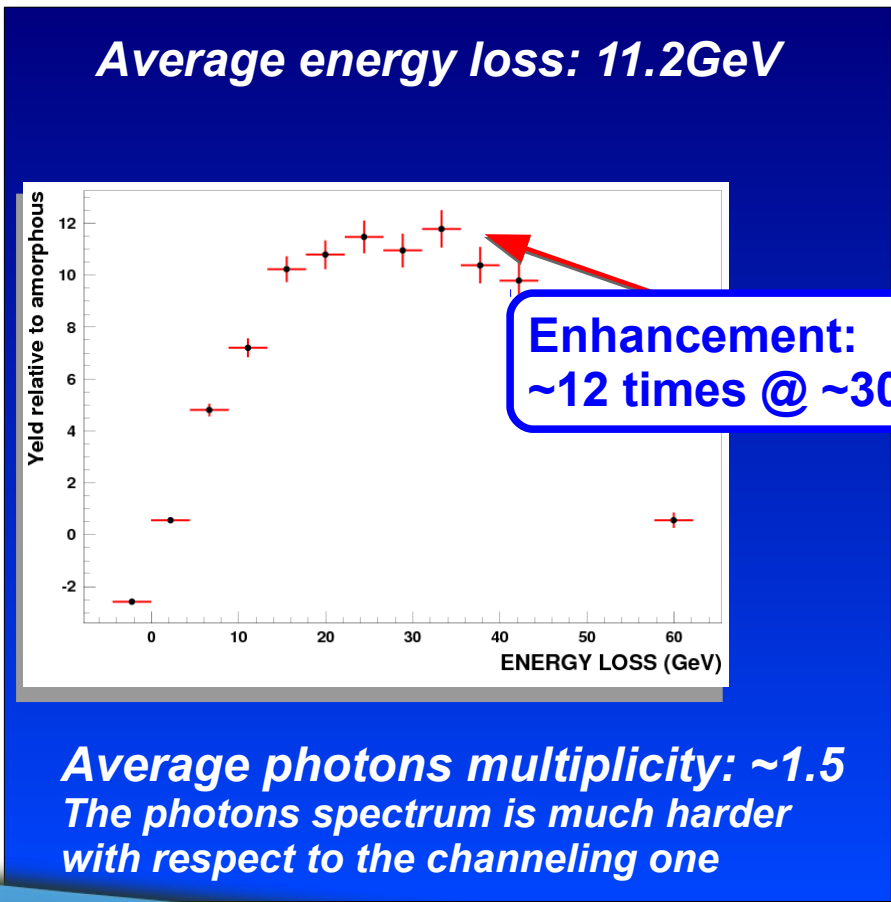

Enhancement:
~12 times @ ~30 GeV

Average photons multiplicity: ~1.5
The photons spectrum is much harder with respect to the channeling one

Volume Reflection

The effect of bending is not negligible:

Strip crystal:

2mm of silicon along the beam
~5m bending radius

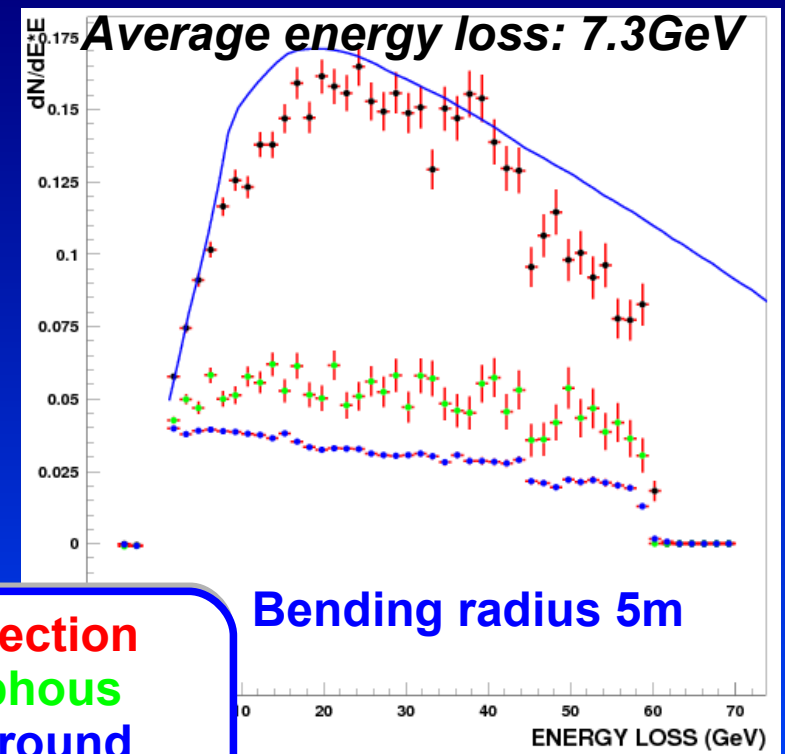
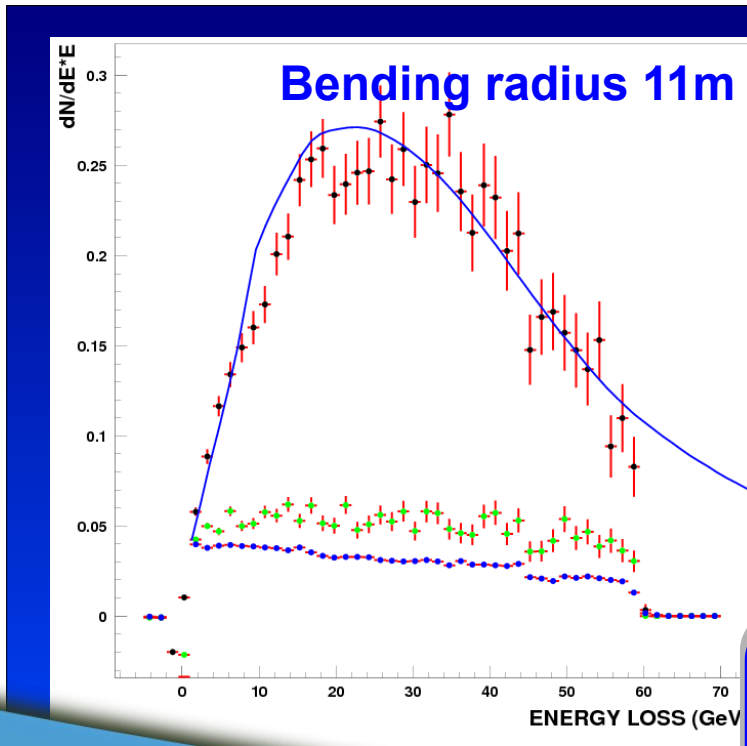
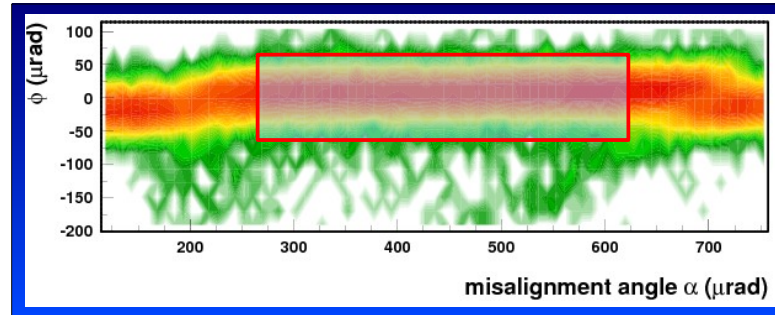
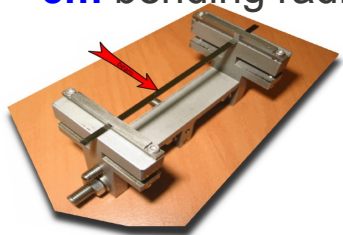

V. Reflection
Amorphous
Background
Calculation

Volume Reflection → larger angular acceptance

➔ Using a series of crystals to increase deflection and radiation is possible!

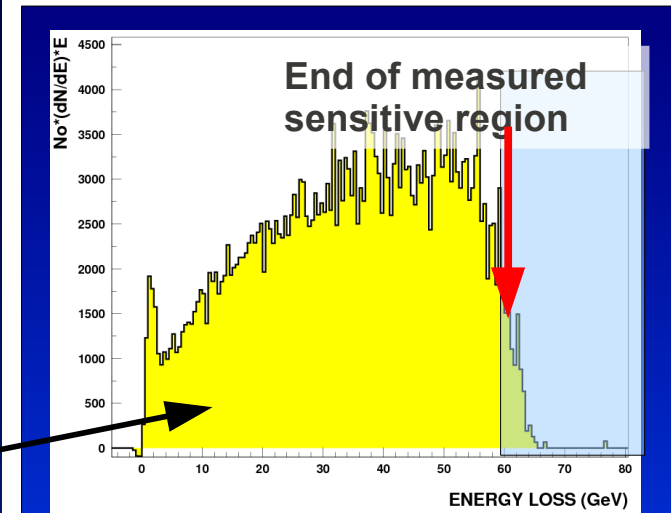
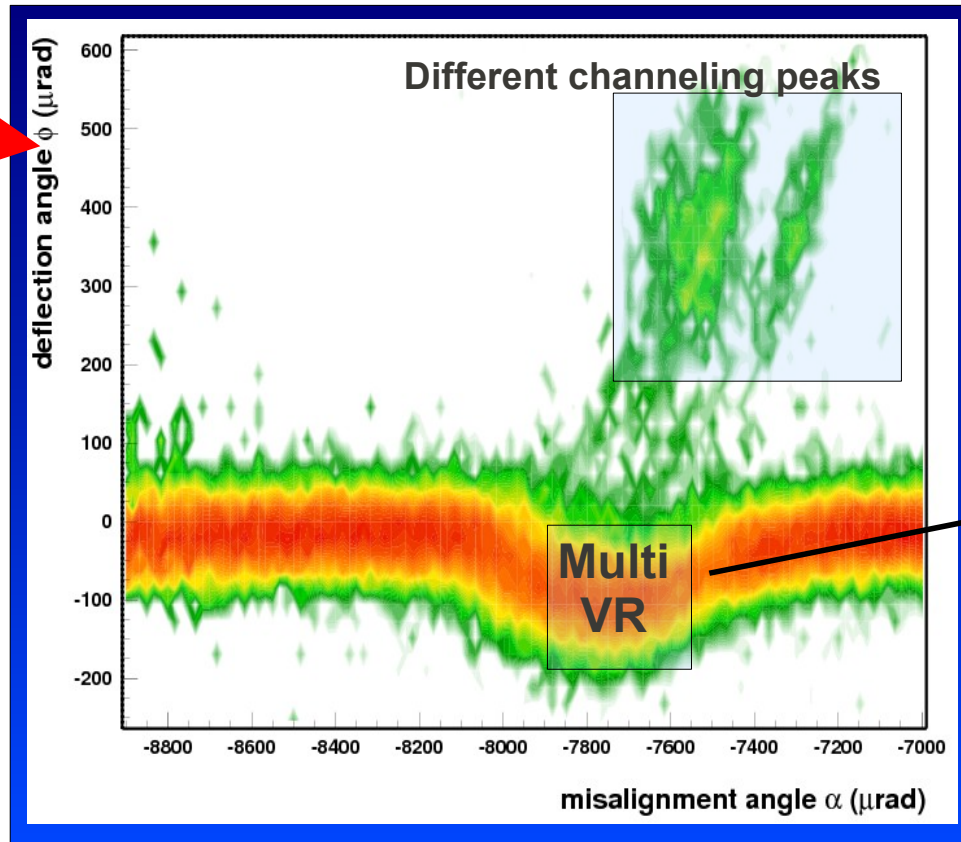
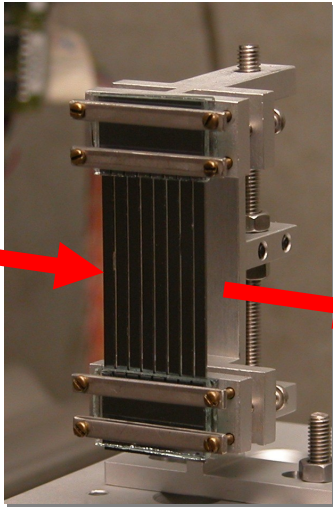

The radiation energy loss shows an amplification but it is not possible either to view all the spectrum or to normalize it as the spectrometer is sensitive until $\sim 60\text{GeV}$

Increasing emitted energy

Axial alignment → **Multivolume reflection in one crystal**

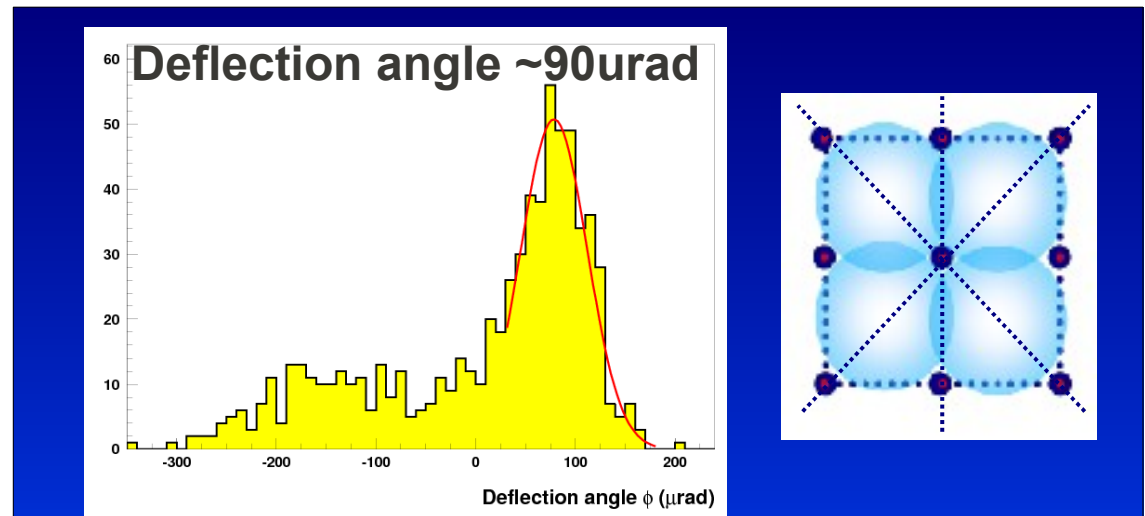
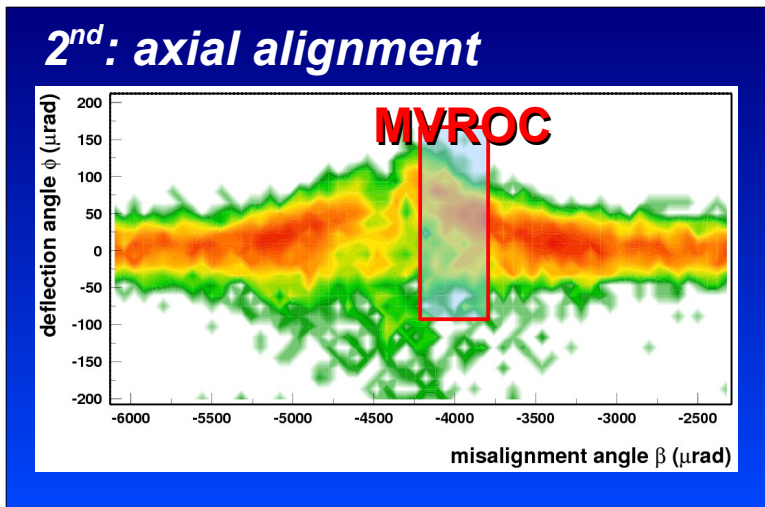
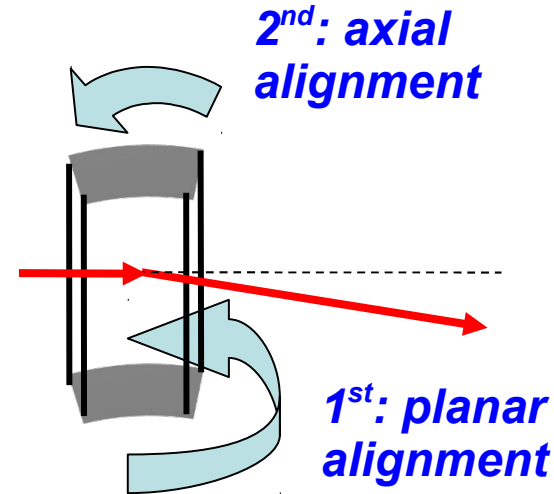
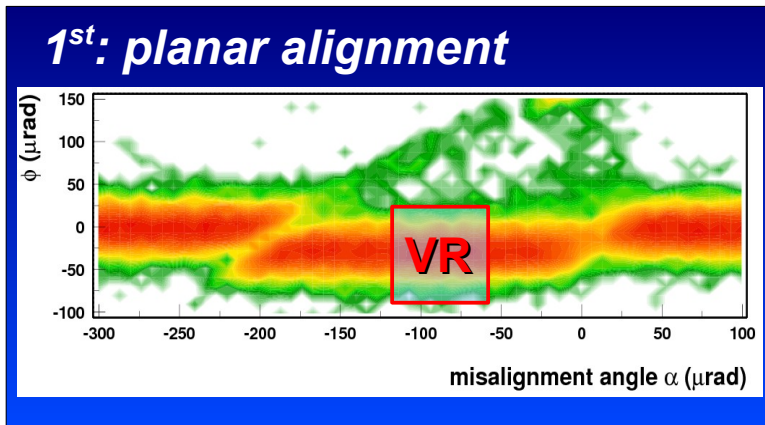

A crystal axis is the intersection of several planes
 If a particle beam impinges onto the crystal at an appropriate angle, it is subject to volume reflections from subsequent planes

Increasing emitted energy

Axial alignment → **Multivolume reflection in one crystal**

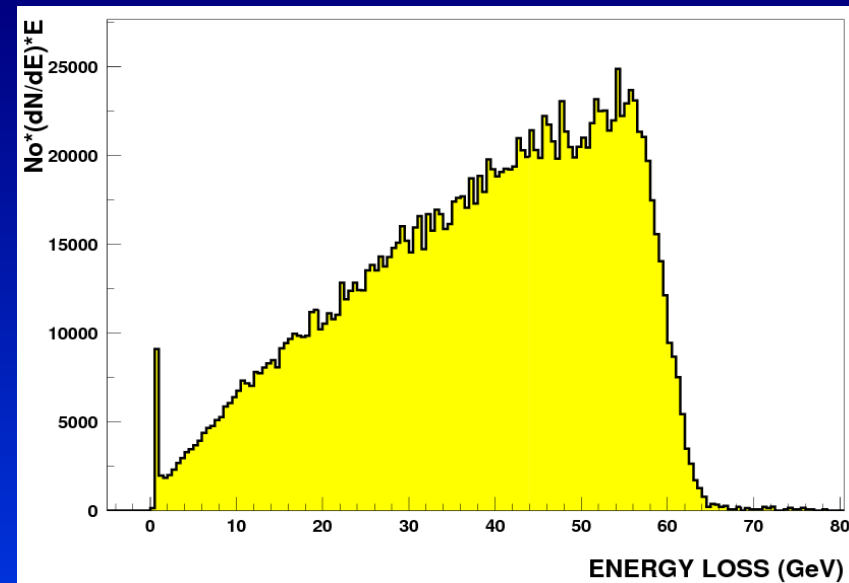
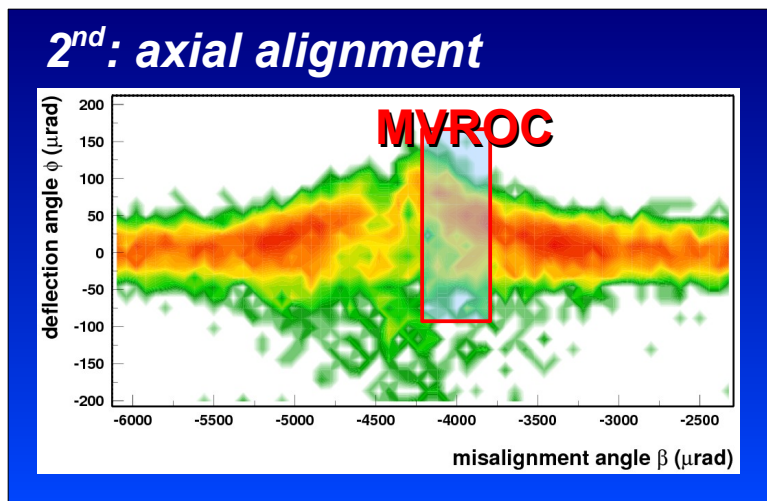
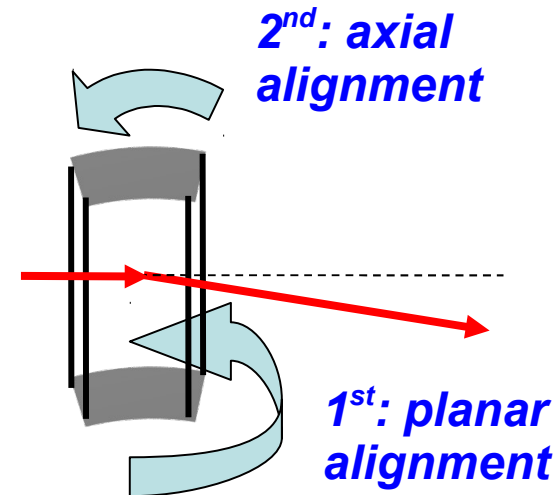
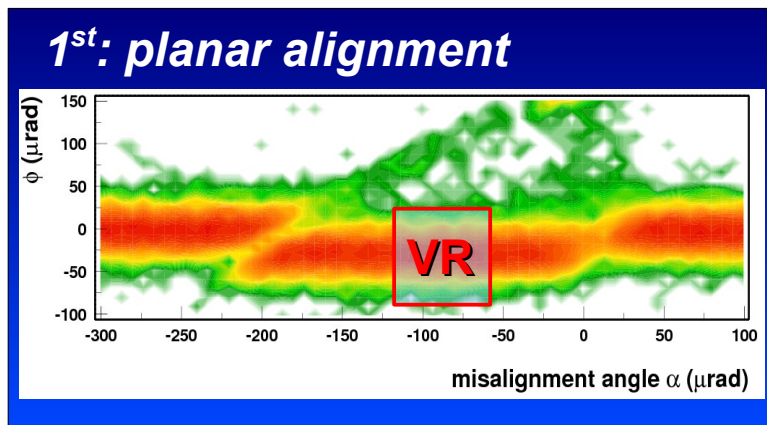

As well as for the “crystal series” the measurement is limited by the spectrometer acceptance thus it provides only a qualitative result



Conclusions and outlooks

❑ Bent crystals → for particle deflection → radiation emission

Volume Reflection

channeling

Characterized from the experimental point of view
In agreement with simulation and theory

❑ Different strategies to increase the emitted radiation are possible

↳ **Series of crystals, axial orientation (MVROC and other effects)**

↳ **Need to measure all the spectrum till 120GeV**

❑ June 2010: new test beam dedicated to the axial effects and to the electrons

↳ **Thanks to the new “photon” calorimeter the whole spectrum has been measured, data analysis is ongoing**

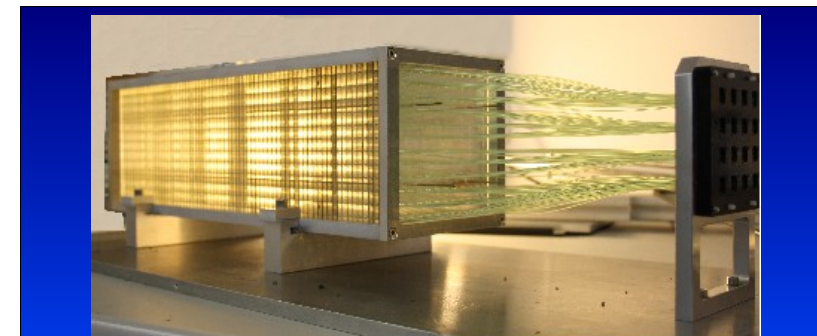

Shashlik calorimeter readout by SiPMs

**High energy photon
production in bent crystals:
the latest measurements.**

Thank you for the attention



Backup 1

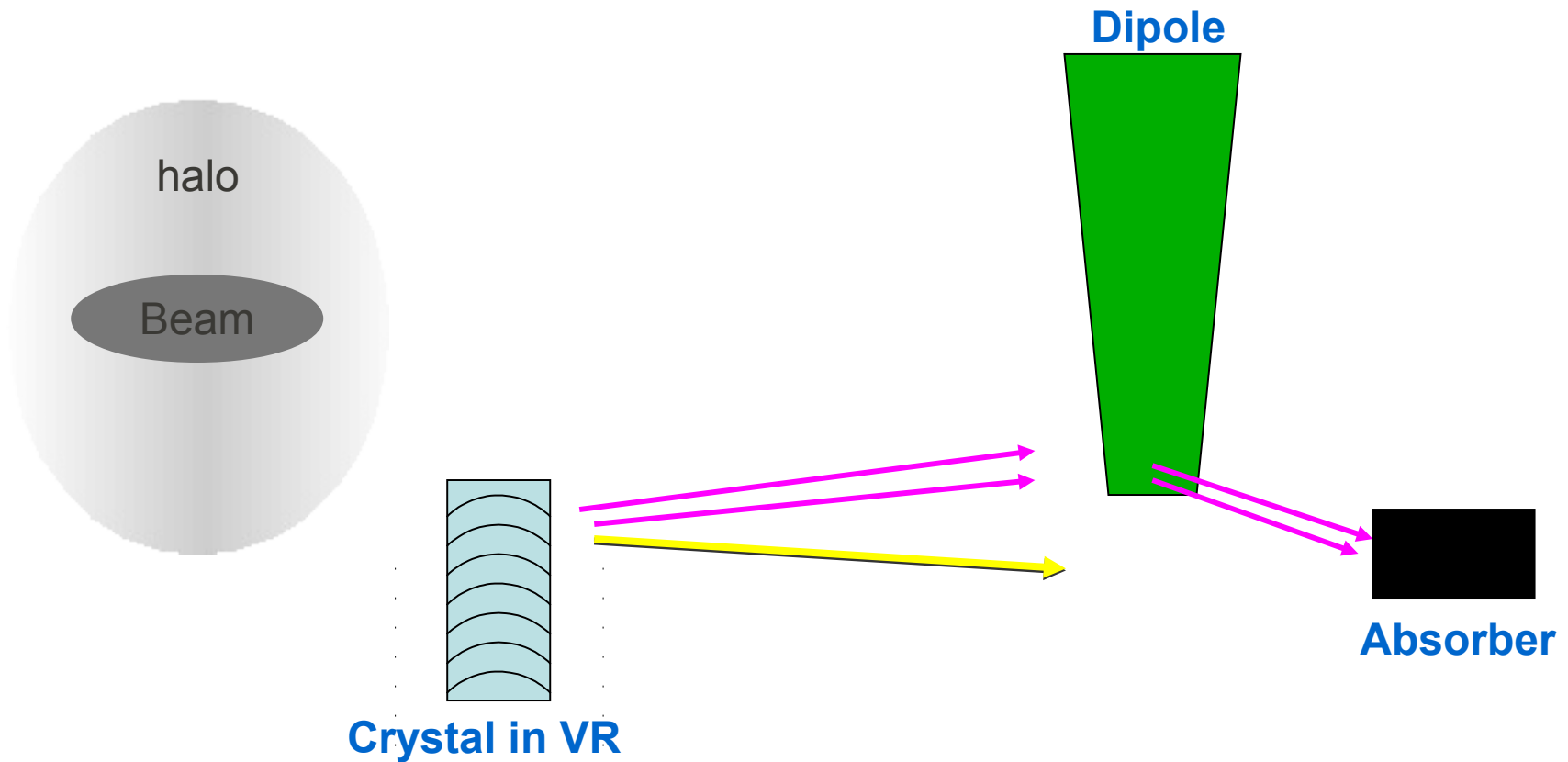

Particles which cross the crystal in VR lose their momentum in radiation and are deflected more by a following dipole

Backup 2

About normalization

Channeling

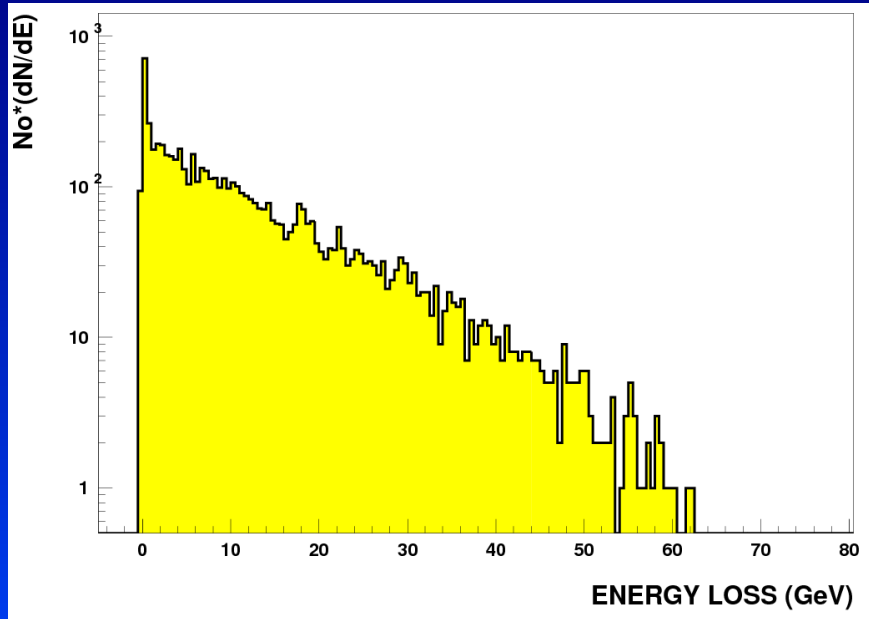

Multi VR

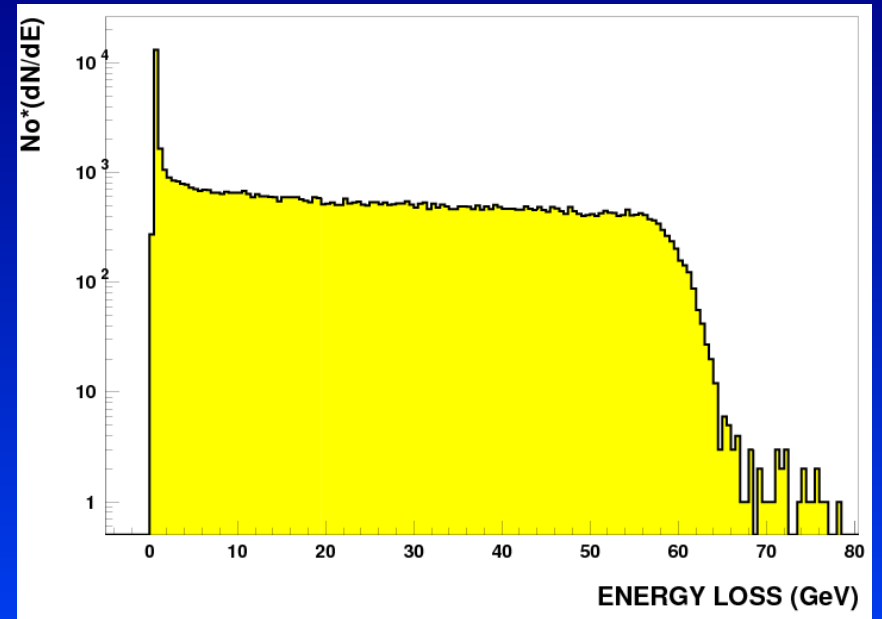

Backup 3

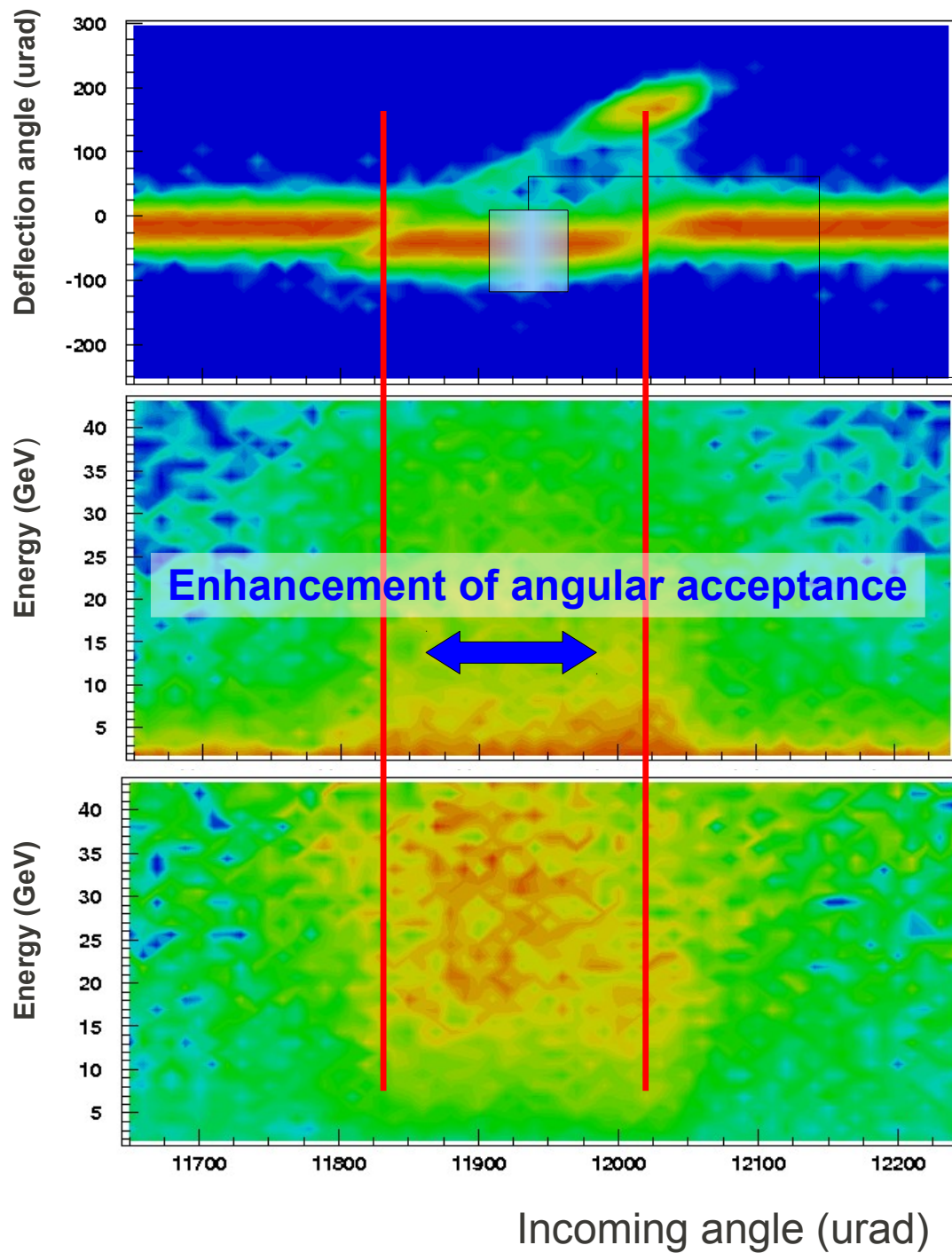

Cut = +/- 50urad (gaussian)

