



Laboratori Nazionali di Frascati

LNF-90/089(R)
17 Dicembre 1990

S. Bianco, F.L. Fabbri, M. Giardoni, L. Passamonti, V. Russo:

**THE S.C.I.C. DETECTOR & Co: E.M. CALORIMETRY AT THE
FRASCATI Φ FACTORY**

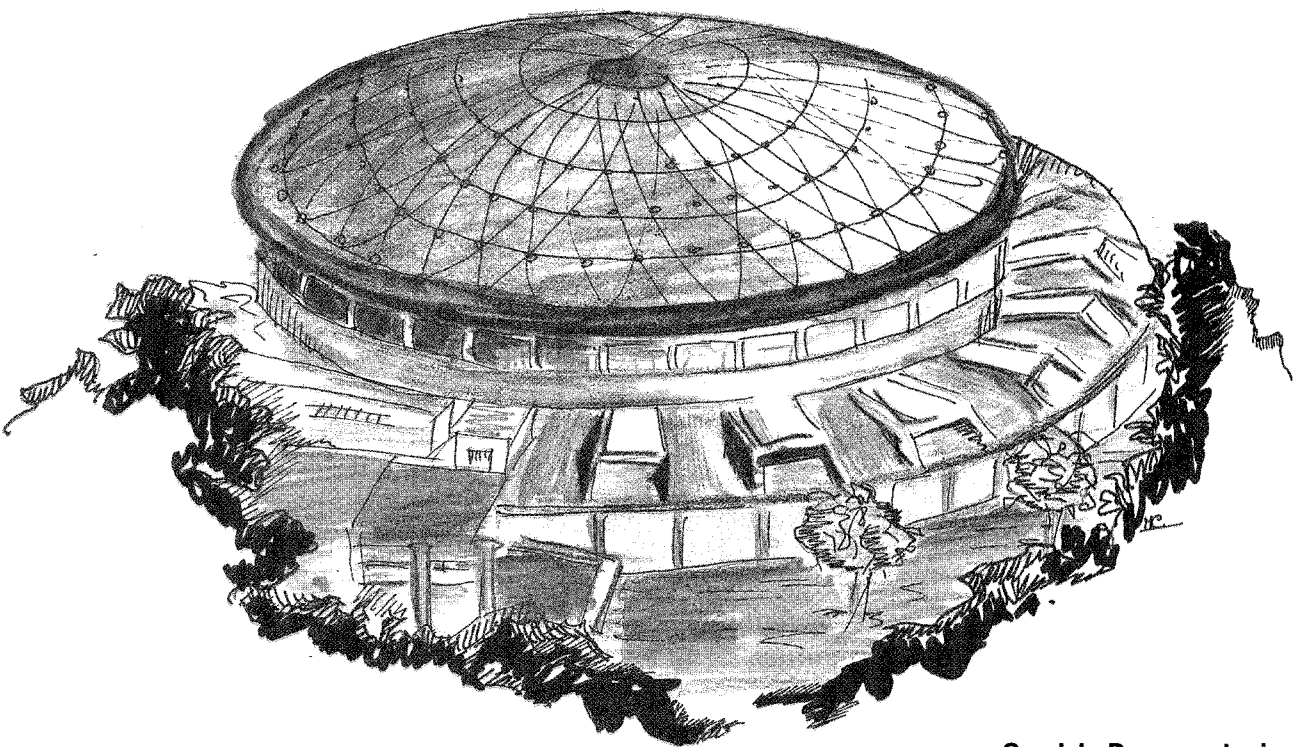

Servizio Documentazione
dei Laboratori Nazionali di Frascati
P.O. Box, 13 - 00044 Frascati (Italy)

THE S.C.I.C. DETECTOR & Co.:
E.M. CALORIMETRY AT THE FRASCATI ϕ FACTORY

S. Bianco, F.L. Fabbri, M. Giardoni, L. Passamonti, V. Russo, A. Zallo
Laboratori Nazionali di Frascati dell'INFN

ABSTRACT

This paper reports baseline ideas for an electromagnetic calorimeter in the γ energy range (20 \div 300) MeV, as required for experimentation at the DAΦNE ϕ factory. The calorimeter design is based on highly segmented CsI elements. Physical performances, technical feasibility and a rough cost estimate are discussed and compared with what envisaged for the liquid Krypton and Pb-SCIFI techniques.

Introduction

Physics requirements for experiments at beauty and ϕ factory machines have had a big impact in the development of electromagnetic calorimeters with improved energy and spatial resolution in a domain of relatively low energies (100 \div 1000) MeV. Experiments at beauty factories as Crystal Ball^[1] and CUSB^[2] pioneered the use of crystal arrays for photon detection in large scale experiments, while the upgraded CLEOIII detector will use a CsI e.m. calorimeter^[3]. For the KEDR experiment at VEPP-4M, an innovative homogeneous detector utilizing liquid Krypton (LKr) is under construction^[4].

Recently a new interest, originated by the possibility of reaching very high luminosity, is grown around the construction of $e^+e^- \phi$ factory machines that would greatly improve our understanding of CP violation in the K mesons system^[5], study semi-rare K decays^[6], and investigate the very foundations of quantum mechanics^[7]. Φ factory projects are under development at Novosibirsk^[8], University of California at Los Angeles^[9], the Netherlands (NIKHEF)^[10] and Frascati^[11].

In this paper we describe a preliminary design of a highly segmented CsI calorimeter for experiments studying CP physics at the Frascati $DA\Phi NE$ ϕ factory. This facility is expected to be ready for experiments in 1995 with a luminosity of $\sim 10^{33} \text{cm}^{-2} \text{s}^{-1}$. The detection of photons in CP violating physics at these machines is more challenging than at a beauty factory, the photon energy being even lower, *i.e.* in the range $(20 \div 300) \text{MeV}$. Excellent resolution, hermeticity and high detection efficiency are required.

1. General requirements for a ϕ factory apparatus

A *general purpose* apparatus, able to respond with due performances to CP physics at $DA\Phi NE$ has been described elsewhere^[12]. It is expected to detect and precisely reconstruct the final states of interest for a measurement of ϵ'/ϵ :

$$\begin{array}{ll}
 K_S \rightarrow \pi^+ \pi^- & K_S \rightarrow \pi^0 \pi^0 \\
 K_L \rightarrow \pi^+ \pi^- & K_L \rightarrow \pi^0 \pi^0 \\
 K_L \rightarrow \pi^+ \pi^- \pi^0 & K_L \rightarrow \pi^0 \pi^0 \pi^0 \\
 K_L \rightarrow \pi^+ e \bar{\nu}_e & K_L \rightarrow \pi^+ \mu \bar{\nu}_\mu
 \end{array}$$

Momenta for charged particles are in the range $(50 \div 250) \text{MeV}$, while energies of photons from π^0 decays are $(20 \div 270) \text{MeV}$.

A possible 4π detector will be composed of a tracking detector, a particle identification device and an electromagnetic calorimeter, inserted in the field of a toroidal magnet. A fiducial volume for the K_L decay fixed in a 150cm radius sphere, corresponding to accepting $\sim 35\%$ of all K_L decays, is considered. Overall dimensions for the apparatus are set in 5m radius by 10m full length. The very thin and narrow Be beam pipe will be surrounded by a low density tracking detector minimizing multiple scattering, one possibility being a He-based ($X_0 > 2000 \text{m}$) TPC or drift chamber. A RICH counter is envisaged as a particle identifier. The electromagnetic calorimeter is the most demanding detector, since it is expected to reconstruct low-energy photons

from $K_{S,L} \rightarrow 2\pi^0$ decays, with high spatial and energy resolutions. Extreme hermeticity is necessary to reach a total rejection factor 10^{-5} against the $K_L \rightarrow 3\pi^0, \pi^+\pi^-\pi^0$ background decay channels.

State of the art techniques based on liquid Krypton or liquid Xenon providing

$$\sigma(E) = \pm 1\% / \sqrt{E[\text{GeV}]}, \quad \sigma(x) = \pm (2 \div 3) \text{mm}$$

have been considered as natural choices^[13]. However, the use of kinematical fits shows that, if a resolution of

$$\sigma(E) = \pm 5\% / \sqrt{E[\text{GeV}]}$$

is obtained, a spatial precision on the photon apex of the order of

$$\sigma(x) = \pm 0.5 \text{ cm}$$

could reach the required K^0 decay vertex resolution^[14]. Another proposed solution^[15] is a calorimeter with excellent time resolution, from which it could be possible to infer the K^0 flight time and therefore its decay length.

The requirement of very good spatial and energy resolution naturally suggests solutions based on homogeneous calorimeters. High Z liquid calorimeters or crystals are natural candidates. However we must consider that determining the shower axis via the centroid of the shower detected energy distribution is not viable for low energy ($\sim 20\text{MeV}$) photons, when the concept of *photon-initiated shower* must be replaced by the idea of *single particle interactions*.

This peculiarity will push us in the direction of a very highly segmented or imaging calorimeter. The design we propose is based on an active imaging-like device made of CsI rods or fibers (the S.C.I.C. Detector) with very high granularity transversally to the photon direction. The S.C.I.C. Detector seems a promising option for physics at a ϕ factory, with reasonable amount of R&D, and affordable cost.

To compare the relative merits of the S.C.I.C. detector and detectors based on liquid noble gases, or Pb-scintillator samplings, we fix these basic parameters: total $15 X_0$ thickness, cylindrical shape, internal wall at $2m$ radius from the interaction point, about $4m$ full length, two end caps. The detector must fit in an external $3m$ radius cylinder.

2. The Pb-SCIFI calorimeter

The Pb-scintillating fibers technique is at the limit of the required energy resolution, but is relatively easy to handle and will be taken as a benchmark in evaluating costs, performances and realization time of other solutions.

The calorimeter is composed of an inner highly segmented tracking section ($5X_0$) making use of scintillating fibers, followed by an outer total absorption $10X_0$ segment (fig.1). Many configurations are possible for a Pb-SCIFI structure, for what regards lead thickness, fiber cross-section, lead-to-scintillator ratio, coordinate sequences^[16]. In the following we shall refer to the arrangement we consider one of the most promising.

The tracking segment will use squared $2mm \times 2mm$ scintillating fibers (or bunch of fibers) arranged in 40 cylindrical shells alternated with $0.7mm$ thick Pb layers (containing 6% of *Sb* or *Ca* for stiffness), for a total of $5X_0$. The sequence of (z, u, w) fibers measuring respectively the (ϕ, ϕ_+, ϕ_-) coordinates is shown in fig.1, inset a). The z fiber is parallel to the cylinder axis, while u and w are tilted at $\pm 45^\circ$ stereo angles. Each fiber is optically divided in two parts running from the side to the half length of the cylinder, where a thin reflector is located to reduce the attenuation length. An extra mural absorber avoids cross-talk between adjacent fibers. About 50 photons are expected to be generated in each fiber per passing-through minimum ionizing particle, at a distance of about $1.3m$ from the readout end^[17]. Optical and electronic read out are arranged at the two ends of the detector, in an adequate path by the endcaps. In this scheme, the total number of fibers is $\sim 500K$, with a variable length of $(2 \div 3)m$.

A less demanding solution is based on optically integrating the light from three lateral adjacent and two homologous coordinates along the direction of the shower development as sketched in fig.1., inset a). This gives a reduction factor of 6, and the total number of channels to be read is now $\sim 85K$, while the light yield for one mip is increased by a factor 2. The light signal is brought to a Multi Anode PMT^[18], or Solid State PMT^[19].

Output signals are then split into charge signals and tracking signals. Charge signals are further grouped, giving a 40 reduction factor before being sent to the ADC for charge analysis, while tracking signals are digitized to a one-bit pattern information.

Charge signals are integrated on 1.2 cm clusters all over the $5X_0$ depth of the tracking section. A better readout possibility is either to optically split the light signal before being converted, or to use both sides of each fiber at the price of an increased thickness of this detector section (fig.2), and then use one of them for tracking pattern and the other one for light amplitude analysis.

The outer ($10X_0$) section is a cylindrical barrel (fig.1. inset b) made of about 2500 bricks $15\text{ cm} \times 15\text{ cm}$ of Pb (+6%*Sb*) with $1mm$ diameter scintillating fibers embedded as in a spaghetti calorimeter, for a ratio in volume $\sim 1 : 1$. This design is originated by the JETSET electromagnetic calorimeter^[20]. The bricks' thickness is $\sim 10\text{ cm}$ corresponding to $10 X_0$. The light from each brick is guided by fused clear fibers to the readout device. Bricks are shaped to avoid any cracks.

The energy resolution and linearity simulated using the GEANT computer code are shown as functions of the photon energy in fig.3. This results include the proper photoelectron statistics and a constant term of 0.5% for miscalibrations, dead channels, cracks, etc. The simulated energy resolution of this detector can be compared, at least for the outer section of our design, with available data^[20] showing that the expected value of $6\%/\sqrt{E[GeV]}$ can be experimentally achieved. The expected spatial resolution for one mip passing through the detector is about 2mm. A simulation is in progress to evaluate the realistic ability to detect the impact point of low energy e.m. showers.

2. The LKr calorimeter

As second reference design we shall consider a solution that is at the opposite limit with respect to the Pb-scintillator technique: a quasi-homogeneous detector which makes use of high density liquid noble gas. Xenon and Krypton are particularly well suited as media to attain excellent energy resolutions in electromagnetic calorimetry. Tab.I shows their physical characteristics compared to crystals.

	LKr	LXe	NaI	CsI	BaF ₂	BGO
$X_0(cm)$	4.6	2.8	2.6	1.85	2.1	1.1
Moliere radius (cm)	6.8	5.6	4.1	3.8	4.4	2.7
-dE/dx (Mev/cm)			4.8	5.6	6.6	9.0
Wave Length (nm)	147	173	415 (Tl)	420 (Na) 565(Tl)	325	480
Refraction index			1.85	1.80	1.49	2.15
Cost (KLit./cm ³)	0.9	5		2.2	3.0	13
Cost (KLit./X ₀ · cm ³)	4.2	14		4.1	6.3	14.3

Table I - Physical properties and costs of materials for homogeneous calorimeters

The use of Xenon is unrealistic for the needed volumes, when considering the related price. We then consider the LKr option. The total depth of the detector will be 15 X_0 , corresponding to a 70 cm thick active volume, 4m internal diameter, 4m full length for a total of 43 m³.

In the inner 5 X_0 the ionization charge is collected by 25μm thick Cu electrodes on sixteen 500μm thick G10 boards, for a 1.5cm LKr gap. Electrode planes are interlayered every 2.3cm in the outer 10 X_0 section, for a total of 20 planes.

In the inner section, signal electrodes are made of 4mm wide Cu strips, both parallel to the cylinder axis and along the cylinder circumference. In the external section, readout electrodes are organized in a tower structure, with 10 cm × 10 cm square pads. The finer sampling in the inner section is needed to get a better spatial resolution for photons on the lower side of the energy range, *i.e.* (20 ÷ 100 MeV). The total number of readout channels is ~ 25K. The total space needed to allocate the cryostat and the cryogenic equipment will extend the thickness of the full detector up to 1 ÷ 1.10m. The two end caps sections will be made of crystals (CsI) because it appears difficult to allocate a cryogenic object in the available space.

We have evaluated via GEANT simulation the spatial and energy resolution of this detector. We included the effect of electronic noise and radioactive background ($\sigma = \pm 6 \text{ MeV}$) on the basis of a computation by P. Franzini^[21]. This value is in agreement with the experimental results recently published by the KEDR collaboration at VEPP-4M^[22], obtained with a shaping time 0.1 times shorter than the total drift time, equivalent to the collection of 5% of the total ionization charge. A constant term of $\pm 0.5\%$ is included to take into account systematics. The expected resolutions as from the GEANT simulation are shown in fig.4. These predictions are experimentally confirmed by data ($E \geq 100 \text{ MeV}$) from the KEDR test^[25].

3. The S.C.I.C. Detector

The solution based on the use of a fine-grained CsI array acts as an imaging-like calorimeter in the initial $5X_0$, for a $\sim 5m^3$ total CsI volume. Realizing the outer $10X_0$ section of the detector with CsI towers would provide an excellent but probably unrealistic calorimeter, as far as budgetary considerations are concerned. We shall therefore investigate an hybrid solution which uses bricks for the outer section, as those described in the Pb-SCIFI design. This hybrid configuration, the Segmented Cesium Iodide Calorimeter (S.C.I.C.) Detector^[23] will guarantee optimal determination of the conversion point of the photon, while the energy resolution will take advantage of the excellent crystal performances primarily in the range from 20 to 100 MeV.

The standard technique used to improve the spatial resolution of crystal counters employed in projective towers and integrating the shower longitudinally is based on the centroid of the energy release in adjacent counters. In the case of the detector we are considering this method cannot not be applied even if cost were not an issue, because of both the non normal incidence angle and the large fluctuations in the lateral development of very low energy showers.

The design of the S.C.I.C. detector is based on thin CsI elements (rods or fibers) placed in successive layers alternatively measuring the Z and ϕ coordinates (fig.5 inset a).

Width and thickness of each element will be determined by the spatial resolution sought, while their maximum length will be limited by the transmission of light inside the elements. Squared CsI rods with cross-sections $5\text{mm} \times 5\text{mm}$ and larger can be machined out of crystals, although they will be probably very costly. Small crystal rods can be extruded from larger crystals. Extrusion is possible by heating the CsI ingot close to its melting point and pressing the softened material. This will produce an extruded metamorphic form of the crystal with the original scintillating characteristics. Extruded rods must still be polished before applying a reflective coating.

The cost of extruded rods is expected to be consistently reduced compared to the fully machined ones. A much better solution is connected to the feasibility of an on-line cladding process during the extrusion of (squared, $25 \div 100\text{mm}^2$) rods, or (squared or round, $1 \div 9\text{mm}^2$) fibers. A proper on-line cladding of the extruded crystals seems technically possible. The challenge is in finding a suitable material with softening point close to the CsI one. Both solutions with higher and lower softening point could be investigated. The technological problems seem not overwhelming, as long as a robust R&D will be developed. Trapping efficiency for clad CsI fibers is expected to be much higher than for stepped-index plastic scintillating fibers, due to the higher CsI refraction index. The superior CsI intrinsic light output is also a clear advantage.

This solution will be the best answer to both performances and budget. In fact, due to the size of the mass production, processing fibers will not imply a relevant cost increase. We consider the clad CsI fibers or rods a real possibility, however we also believe that the extruded and polished rods technology, today already available, will allow us to design a detector with optimal performances. In the following we conservatively describe a segmented structure achievable even if clad fibers or rod were not available.

The maximum length for unclad rods is limited by the transmission efficiency of the reflective coating. The structure of the inner $5.2X_0$ section is based on 10 layers of 6mm wide, 9mm thick CsI rods. In each layer, fibers are alternatively parallel and perpendicular to the cylinder axis, measuring the ϕ and Z coordinates respectively. The cylindrical shape will be approximated by tile-like, $\sim (60\text{cm} \times 60\text{cm})$ planar modules. CsI fibers will not allow to follow the cylinder curvature: experience acquired on small quantities shows that after some bents the fiber will broke^[24]. Each layer of each planar module will be composed of about 100 CsI elements, up to a total of 180K CsI elements, for a $\sim 5\text{m}^3$ total volume.

Various options are possible for the readout of both Z and ϕ elements. Each element could be read out by a dedicated optodevice at one end (fig.6a), with a mirror installed on its second end. Alternatively, it can be read at both ends by one device facing two adjacent elements (fig.6b). Both solutions will add up to the 180K total

readout channels. A reduction of a factor 2 in the total number of channels can be obtained by sharing one optodevice between two elements, on one end only (fig.6c).

As in the Pb-SCIFI design each output signal is either split before (or after) amplification, or the light output from the second element end is made available. One portion of the output signal provides 90K spatial one-bit informations, while the remaining portions are summed for energy measurement before being sent to the ADC. A reduction factor of 40 in the number of ADC channels (for a total of 2500) is obtained by summing together clusters of 8 adjacent elements in Z or ϕ over the entire $5X_0$ thickness (5 layers for each coordinate). Such lateral segmentation corresponds to about one Molière radius. Once a decision on the readout scheme is taken, a geometrical arrangement using larger $\sim (100cm \times 100cm)$ planar modules could be considered, with the advantage of a reduced total thickness.

For what concerns the total absorption section, if we adopted the straightforward solution of using CsI bricks the total CsI volume needed would add up to $15m^3$, causing an unacceptable growth of costs. The alternate solution for the total absorption section we consider very promising is the use of Pb-SCIFI bricks, already described in §1.

We have fully simulated the response of such a hybrid S.C.I.C. Detector finding respectable energy resolution, with the bonus of a large reduction of costs with respect to the full CsI detector. The simulated energy resolution reported in fig.7 for the S.C.I.C. Detector is quite good especially at low energy where the photon releases most of its energy in the CsI. Inner-outer energy correlations are shown in fig.8.

4. Conclusions

In fig.9 the inefficiencies for the S.C.I.C. detector and the Pb-SCIFI calorimeter are shown as functions of the photon energy. To make an overall comparison among the three detectors we must examine their physical performances, technological feasibility, R&D requirements, availability of materials (Kr, CsI) and, last but not least, cost. Any price evaluation at this stage is a dangerous but necessary exercise, however approximately representative of the cost differences among designs.

The cost estimate (tab.II) of the active media is based on asymptotic quotations for the SSC in the case of the scintillating fibers and on *guided* extrapolations of costs quoted by the producer for very big quantities in the case of LKr. For what concerns the CsI fibers, we increased the price of CsI crystal obtained by a KEK experiment by a factor 1.3. The cost of fibers or rods extrusion would not have a big impact on such large quantities. However, the cost for R&D is not included even if we believe that, taking into account today's technological reality, it would be relatively small. The cost of machining the CsI rods (if necessary) can hardly be evaluated but a good guess is

to add a 18% to the CsI price in Table II. The main parameters of the designs are also shown in Tab.II, as well as cost figures (in GLit.) based on the number of readout channels of solution 2.

	LKr	SCIFI	CsI
Cost active medium($KLit./cm^3$)	0.9	0.55	2.2
Volume(m^3)	43	8.4 SCIFI	5 CsI+4.3 SCIFI
Read out chnls(<i>Solution1</i>)	25K	500K (one bit) 5K (ADC)	180K (one bit) 5K (ADC)
Read out chnls(<i>Solution2</i>)		85K (one bit) 5K (ADC)	90K (one bit) 5K (ADC)
Total cost active medium (GLit)	39	4.6	11+2.3
Mechanics + readout(<i>Solution2</i>)	11	15.4	17.7
Total	50	20	30

Table II - Design parameters and synopsis of costs.

The cost of both signal processing and electronics is subject to the very rapid evolution of the field, under the effect of future european and american accelerator projects. Our estimates are based mainly on evaluations originated from SSC projects attacking similar problems and must be considered an *upper limit*. The cost of the end caps are estimated as 30% of the main (barrel) detector in the Pb-SCIFI or SCIC Detector designs.

The homogeneous calorimeter based on liquid Krypton is very attractive because of its physical performances. However, no detector of this kind is today operational in an experiment. The LKr electromagnetic calorimeter under construction for the KEDR detector at VEPP-4M will have an active volume of $14 m^3$, *i.e.* only one third of the volume foreseen for the *DAΦNE* ϕ factory. A few liters prototype has been recently tested in Milano by the italian component of the KEDR collaboration. Results obtained^[25], as those from a larger prototype under study at Novosibirsk^[26], are very encouraging even if no measurements are available yet for photon energies less than $100 MeV$.

The cryogenic technology involved is well known and does not seem to cause problems even at such a large scale^[27]. In spite of these attractive characteristics, the cost of such a detector is very high and also the procurement of the gas is a non-trivial problem. The total amount of gas needed corresponds roughly to 1.5 years of the world-wide production of Krypton. We have investigated the possibility of activating other suppliers: this would be a possible^[28], although difficult, task to be accomplished

in a short time. Any project of this kind has to undergo the construction of several test prototypes of increasing volume, with no certainty that the final detector, due to the importance of the scale factor, will not show unexpected problems.

Unfortunately the results from the KEDR experiment would hardly be available soon enough. In this respect, any experiment at *DAΦNE* willing to use LKr would benefit from the experience of the Italian collaboration at KEDR. A joint-venture with a Kr producing country would be absolutely necessary to free the project from uncertainties of the commercial market.

Sampling calorimeters based on Pb-SCIFI^[30] and Pb-MWPC^[31] have been considered by many authors for the ϕ factory. The Pb-SCIFI design we have considered takes advantage from the scintillating fiber technique, and allows the construction of a detector with improved energy and spatial resolution with respect to the old fashioned Pb sampling calorimeters. The performances reachable with this technology are at the limit of requirements for physics at a ϕ factory. However, compactness, self-supporting structure, relative ease of construction and low cost are appealing features. The scintillating fiber and related R&D in the achievement of low cost optoelectronics read out, originated by the SSC and LHC projects, are no-cost advantages. Further investigations, both via simulations and experimental tests, would be necessary to reach an optimized design and to really understand if its performances in terms of efficiency, spatial and energy resolution could satisfy the needed requirements.

The S.C.I.C. Detector has the advantage of excellent physical performances in spatial and energy resolution combined with a straightforward construction technique. Besides, the efficiency for low energy photons will be much better than in the Pb-SCIFI design. The estimated cost is reasonable, compared to the physical performances. The S.C.I.C. Detector will not be as compact as Pb-SCIFI, although its overall dimensions will still fit in an acceptable radius. The rod made design does not require new technology while clad CsI fibers, achievable with consistent R&D effort, would allow better light collection, more compact design, optimized mass production and reduction of readout channels. We definitively consider the SCIC Detector a very promising option for the Frascati ϕ factory.

Acknowledgments

Thanks are due to R. Biesenbach, D. Day, N. Ligthelm, E. Martella, M. Meoni, L. Palamone and P. Verburg for technical and commercial informations on Krypton, scintillating fibers, CsI crystals. We are indebted to P. Frabetti and F. Palombo for

introducing us to the test of the *Milan* LKr prototype. F. Baldacchini kindly helped us in evaluating the technical cryogenic problems and costs related to the Lkr detector. We gratefully acknowledge H. Mendez, N.I. Qazi and S. Sarwar for many illuminating discussions.

Finally, we thank R. Baldini-Celio and P. Laurelli for encouragement and support during this work, and L. Daniello for many skillful technical suggestions.

REFERENCES

- [1] M. Oreglia et al., *Phys. Rev.* **D25**, (1982) 2259-2277.
- [2] L.J. Spencer, Ph.D. Thesis, State Univ. of N.Y. at Stony Brook, (1982) (*unpublished*).
F. Pauss et al., *Phys.Lett.* **130B**, (1983) 444-448.
- [3] Updated proposal for improvements to the CLEO detector for the study of e^+e^- interactions at CESR, Cornell report CLNS85/634, (1985).
- [4] KEDR detector for VEPP-4M proposal, IHP 87-Novosibirsk (1987).
- [5] D. Cocolicchio et al., CP violation measurements at the ϕ resonance, LNF 90/031(R), (1990) 49-62.
- [6] R. Barbieri et al., Relazione del gruppo di studio sulla ϕ factory, (*in Italian*), LNF-90/041(R) (1990).
- [7] R. Baldini-Celio et al., Kaon Physics at a Φ Factory, LNF-90/07(R) (1990).
- [8] L.M. Barkov et al., ϕ factory project in Novosibirsk, Novosibirsk USSR prepr(1989).
- [9] V.A. Barletta et al., A linear collider ϕ factory and beam dynamics test machine, prepr. Center for Adv. Acceler.. UCLA, USA (1989).
- [10] J.I. Botman et al., Initial design of a ϕ factory, NIKHEF prepr. (1988).
- [11] P. Amadei et al., Ares design study: the machine, LNF-90/005 (1990).
- [12] M. Giorgi et al., Physics programme at a ϕ factory: physics and detector summary, LNF 90/031(R), (1990) 2-48 .
- [13] G. Barbiellini et al., The ϕ factory: physics motivations and feasibility problems, Particle World. Vol.1. No.5. (1990) 138-147.
- [14] A. Calcaterra et al., Measurement of K_L^0 decay point and mass via kinematics fits, LNF-90/031(R) (1990) 195-209.
- [15] G. Batignani et al., A modern apparatus for study of the $K^0\bar{K}^0$ system from the $\Phi(1020)$ produced in e^+e^- , LNF-90/031(R) (1990) 211-230.
- [16] S. Bianco et al., Lead-scintillating fiber calorimeters at a ϕ factory, *in preparation*.
- [17] Bicron Corp., Newbury, OH (USA).
Kyowa Corp., (Japan)
Politech s.p.a., Carsoli (Italy).
- [18] Hamamatsu Photonics K.K., Hamamatsu City (Japan).
Philips Corp.

- [19] Rockwell Corp., Rockwell International Science Center, Anaheim, CA (USA).
- [20] D.W. Hertzog et al., **A high-resolution lead/scintillating fiber electromagnetic calorimeter**, *Nucl. Instr. and Meth.* **A294**, (1990) 446-459.
- [21] P. Franzini, **Signal and noise in a homogeneous, high Z, liquid calorimeter**, LNF-90/051(R) (1990).
- [22] V.M. Aulchenko et al., **Investigation of an electromagnetic calorimeter based on liquid krypton**, *Nucl. Instr. and Meth.* **A289**(1990) 468-474.
- [23] S. Bianco et al., **Electromagnetic calorimetry at ϕ factories: a preview**, *presented at the ICHEP, FNAL 29 October 1990*.
- [24] P. Hrich et B.K. Utts, Harshaw Solon Technologies Corp., OH (USA) *private communication*.
- [25] F. Palombo, **Liquid krypton electromagnetic calorimeter for KEDR detector**, *presented at the ICHEP, FNAL 29 October 1990*.
P.L. Frabetti and F. Palombo, *private communication*.
- [26] V.V. Anashin et al., **KEDR Status report**, May 1990 (*unpublished*).
- [27] F. Baldacchini, *private communication*.
- [28] N. Ligthelm, Atomic Energy Corporation of South Africa Ltd., *private communication*.
- [29] P. Franzini, *presented at the Workshop on e^+e^- physics at high luminosity, Stanford (1985)*.
- [30] R. Battiston et al., **Status and perspectives of the K decay physics**, LNF-90/031(R) (1990) 63-121.
- [31] A. Del Guerra et al., **Monte Carlo study of the development of a low energy electromagnetic shower: preliminary results**, LNF-90/031(R) (1990) 231-234.
- [32] S. Smith et al., *presented at the SLAC Summer Institute (1988) referenced in [30], p.76*.
Review of Particle Properties 1990, Phys.Lett.B239 (1990), p.III.20.

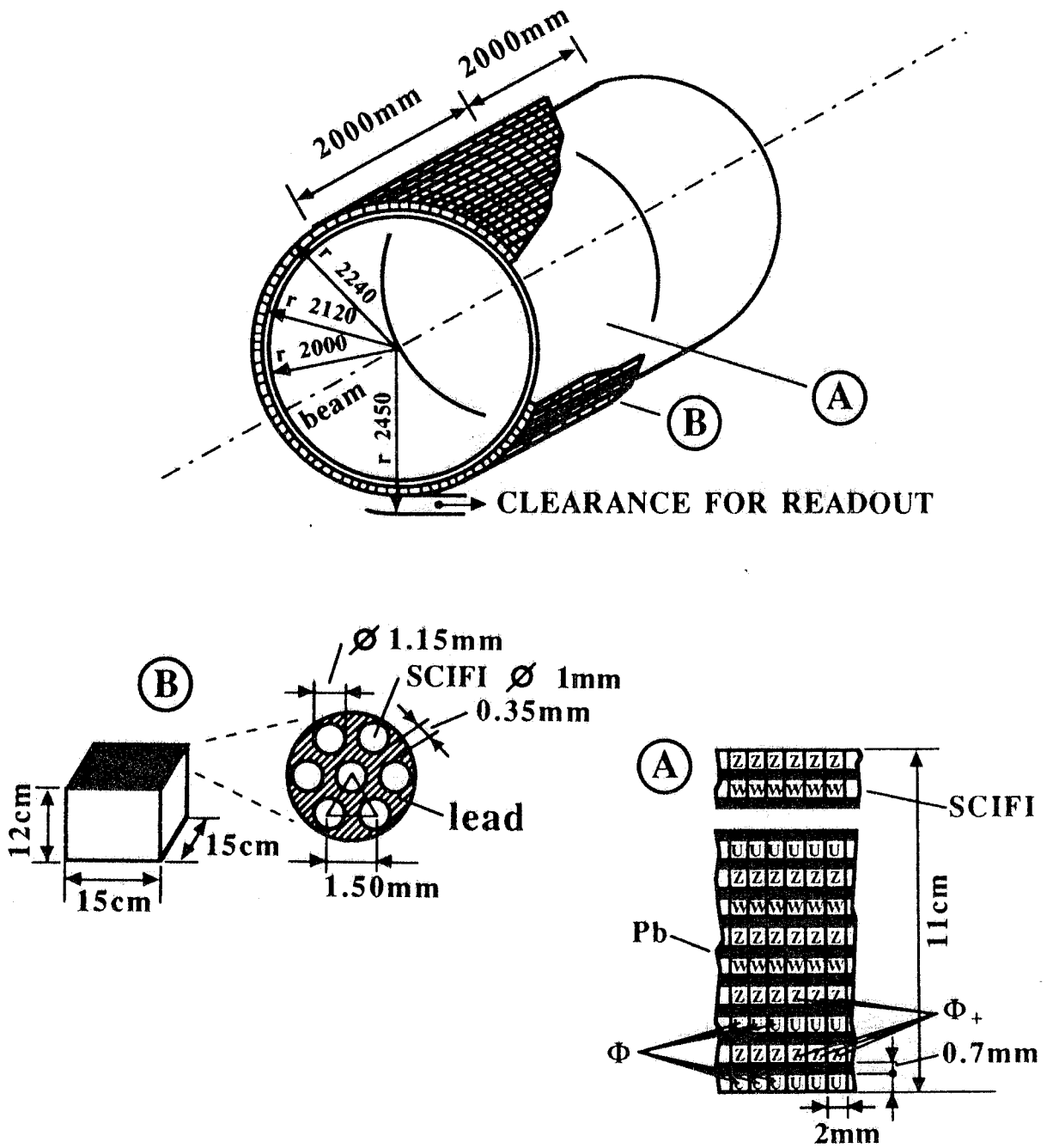

Fig. 1 - The Pb-SCIFI calorimeter. Insets a) and b) show the structure of tracking and total absorption section respectively.

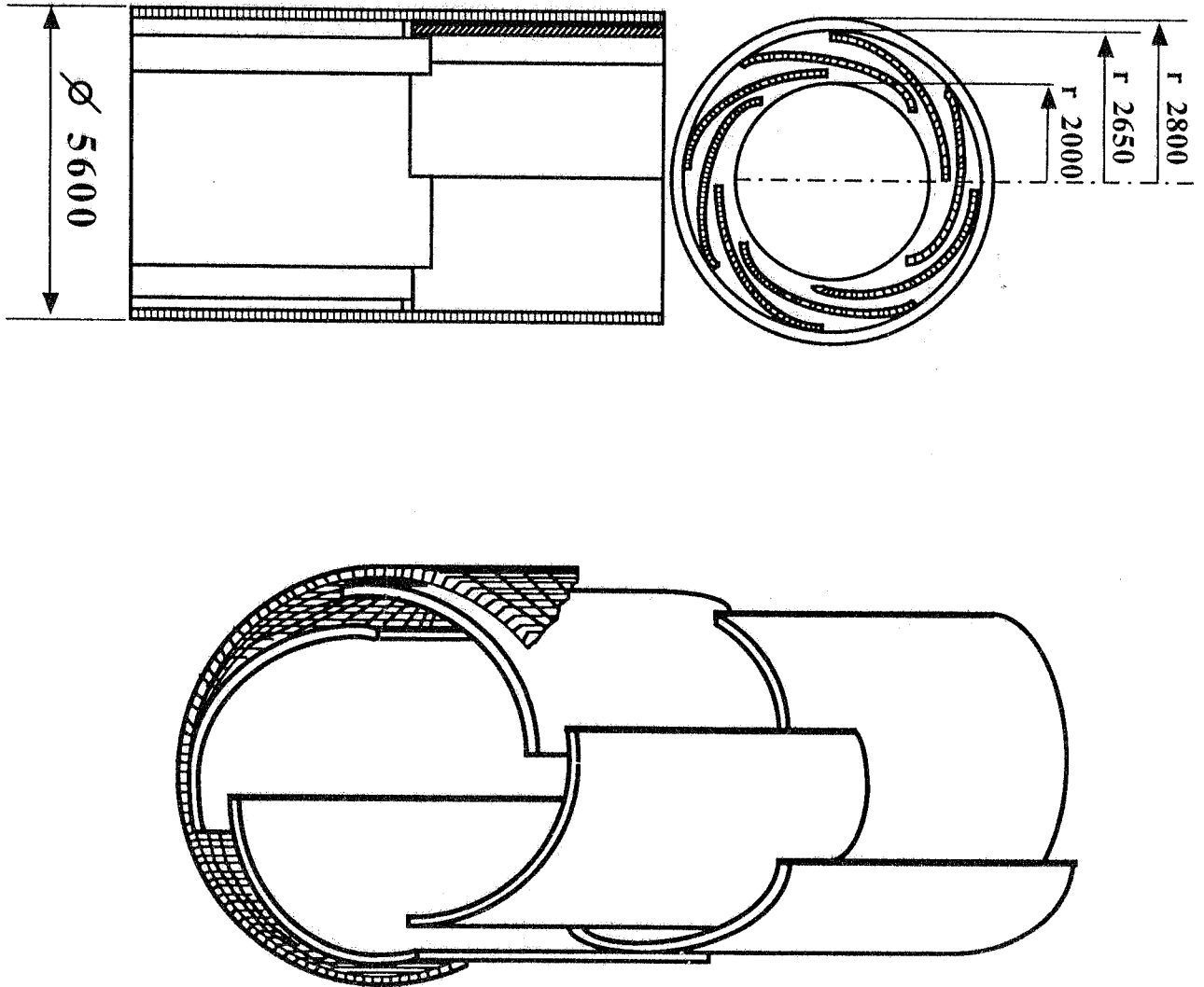

Fig. 2 - Artist's view of a double side access solution for the readout of the Pb-SCIFI calorimeter.

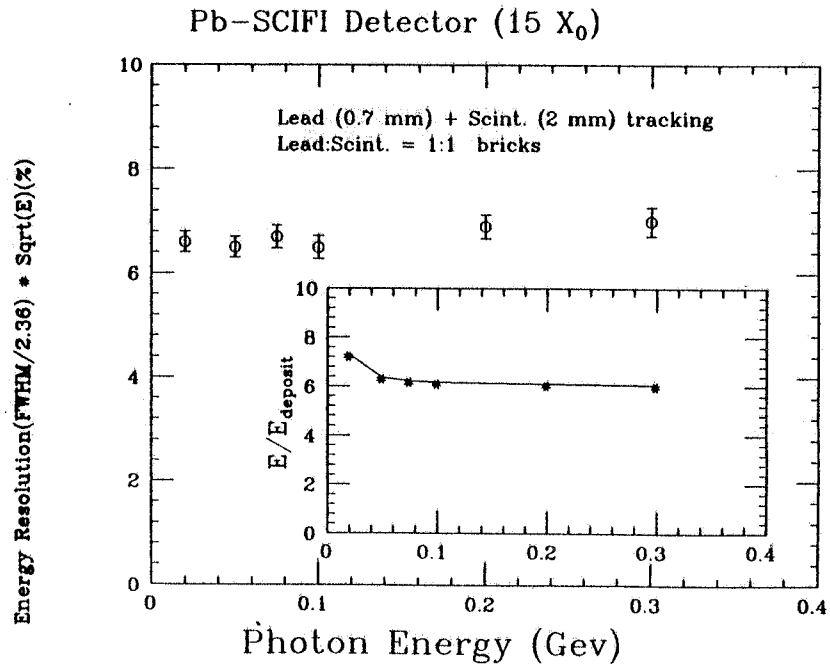

Fig. 3 - Simulated energy resolution and linearity for the PB-SCIFI calorimeter. Photostatistics and systematics are included.

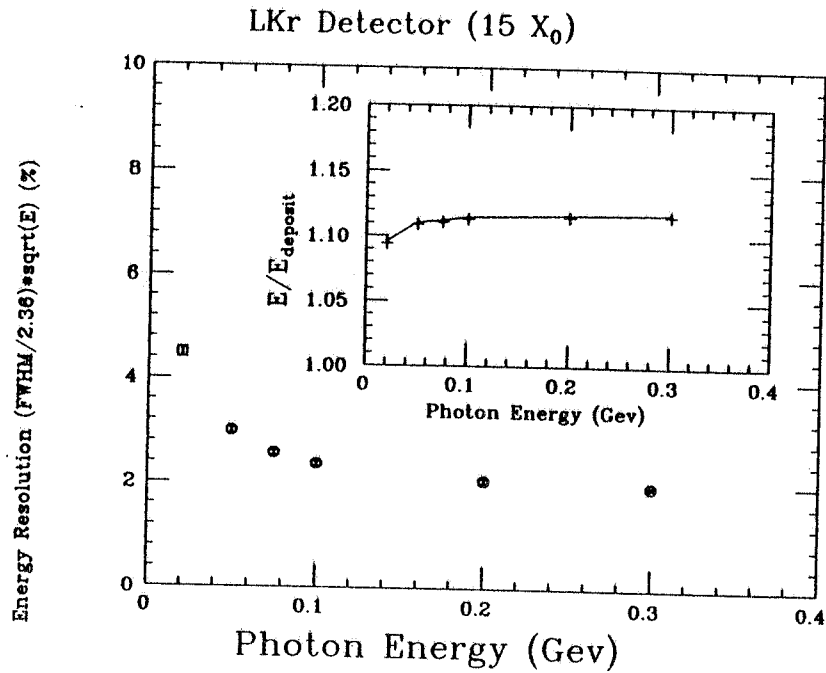

Fig. 4 - Simulated energy resolution and linearity for the LKr calorimeter. Radioactive noise, electronic noise and systematics are included.

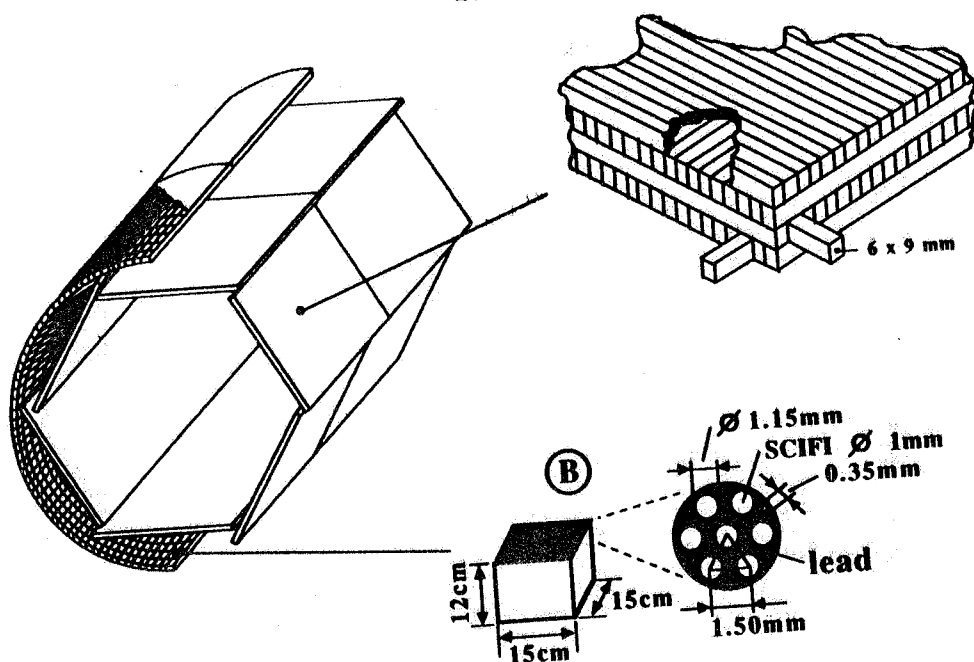

Fig. 5 - The S.C.I.C. Detector. Insets a) and b) show the structure of tracking and total absorption section respectively. The tracking section is shown in the solution adopted with CsI fibers, utilising $\sim 2m \times 2m$ planar modules.

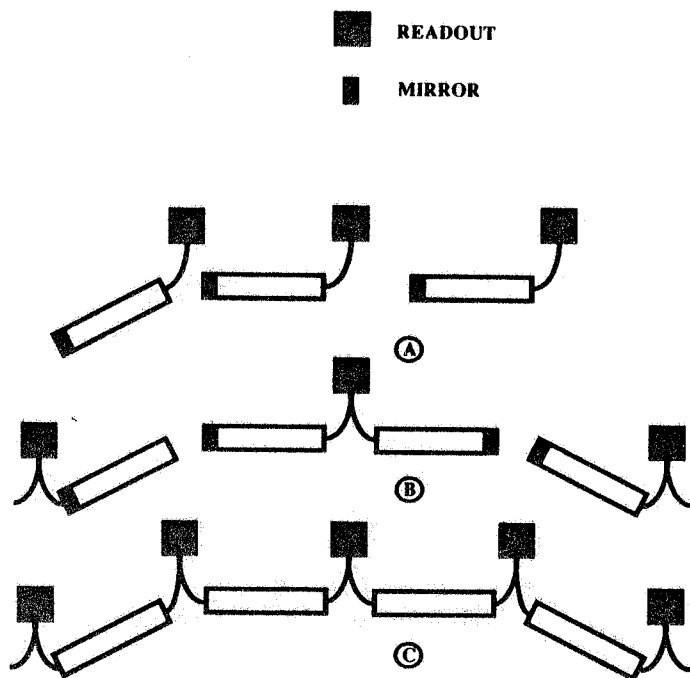

Fig. 6 - Single a), and double b),c) readout for S.C.I.C. elements.

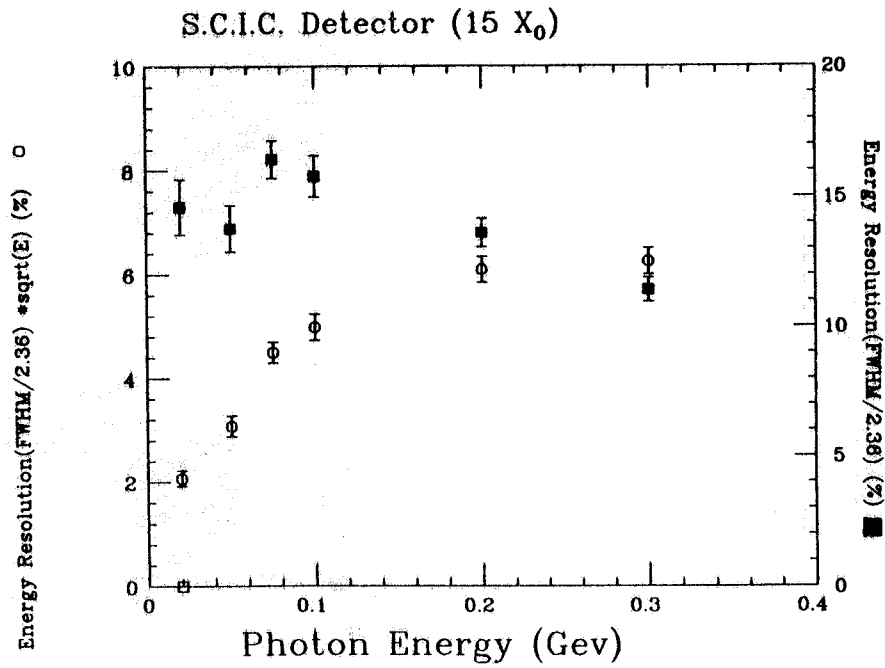

Fig. 7 - Simulated energy resolution for the S.C.I.C. Detector. Photostatistics and systematics are included.

S.C.I.C.

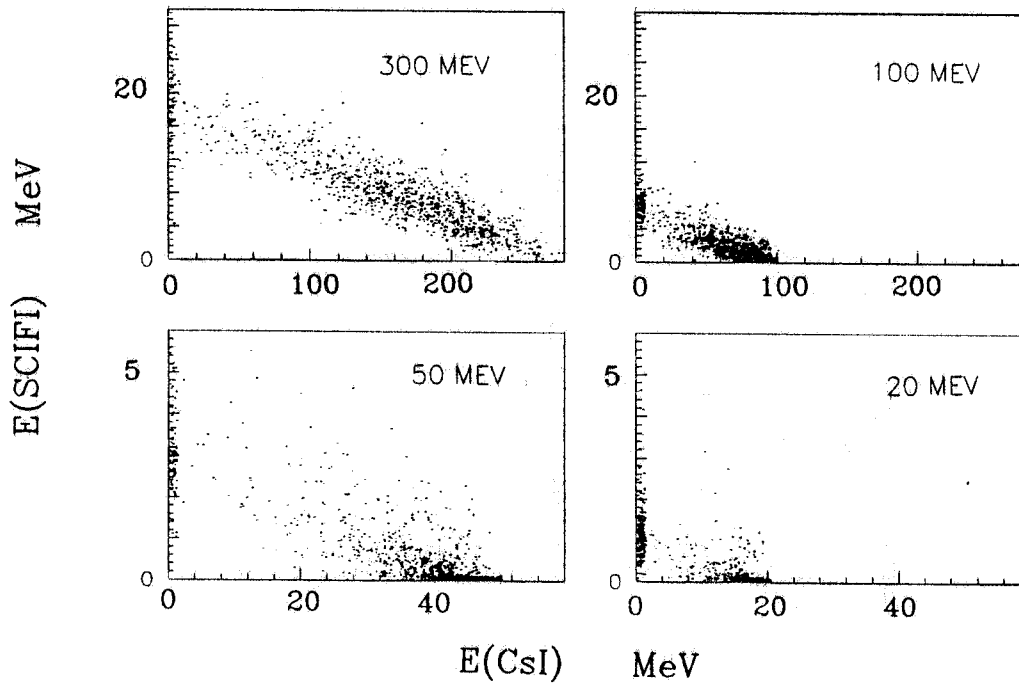
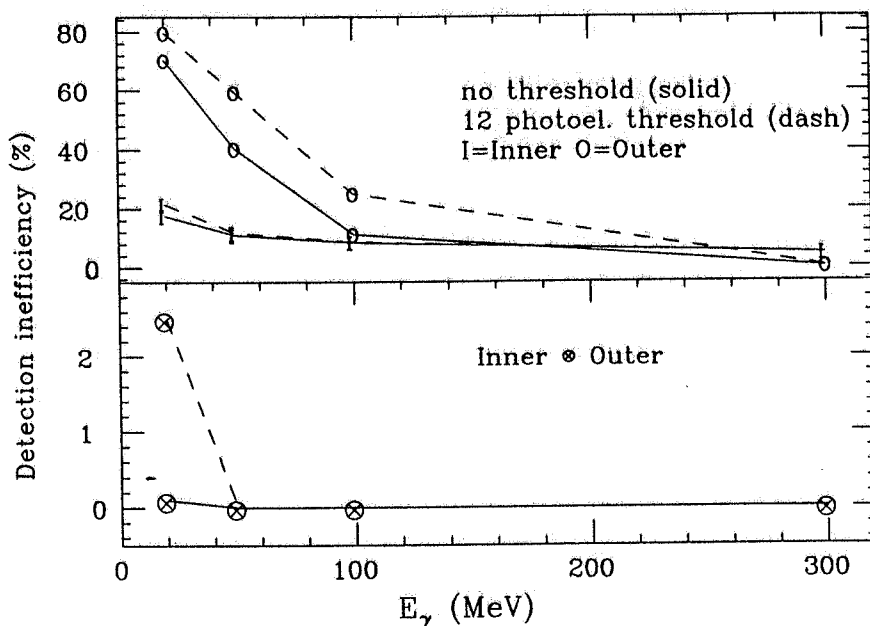

Fig. 8 - The correlation between the energy detected in the inner CsI tracking section ($\leq 5X_0$) and in the outer Pb-SCIFI total absorption section ($5X_0 \div 15X_0$) for the S.C.I.C. detector.

a) Pb-SCIFI



b) S.C.I.C.

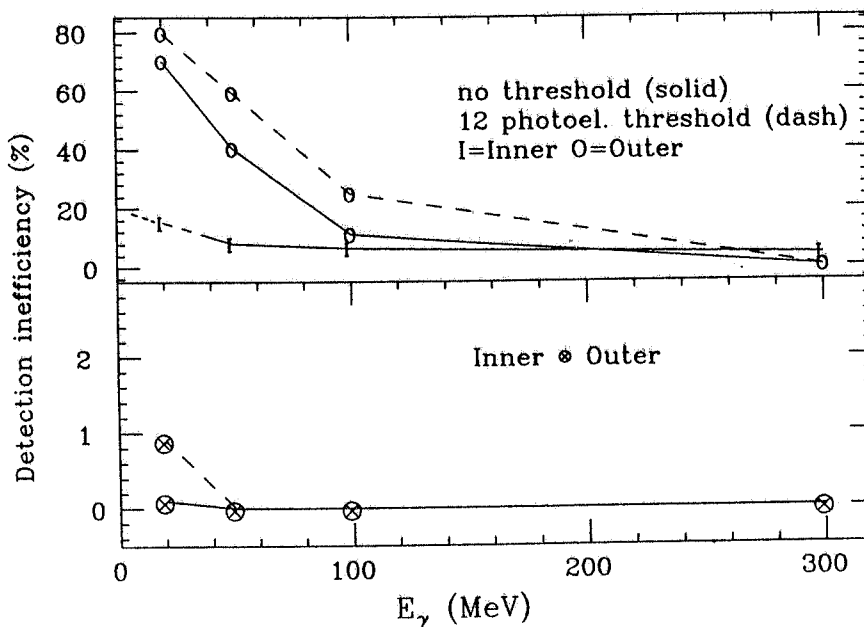

Fig. 9 - Inefficiency curves for the Pb-SCIFI (a) and S.C.I.C. detector (b). The simulation (1000 events per data point) does not take into account the inefficiency due to photonuclear interactions, estimated^[32] in Pb at the level of 25% at 20 MeV, and 0.4% at 40 MeV.