

FREQUENCY LOCK IN HIGH-Q RESONANT CAVITY TESTS

A. Gallo

Istituto Nazionale di Fisica Nucleare, Laboratori Nazionali di Frascati
P.O. Box 13 00044 Frascati (RM), Italy

ABSTRACT

The control electronic equipment for high-Q cavity RF tests is mainly made up by an analog feedback system which has to keep the exciting frequency well inside the resonator bandwidth at every time; failures of such a system may cause troubles in cavity parameter measurement.

In this paper we present a mathematical model for a frequency lock system as a useful design tool; the analysis is mainly based on linear system feedback theory and the principles exposed are easily extendible to other kinds of analog loops, like phase and amplitude stabilization of accelerating RF voltage in particle accelerators circuits.

For a better understanding, readers should be familiar with some fundamental topics like Laplace transform and stability criteria of Bode and Nyquist. Details of these theories are reported in the mentioned references.

1. Introduction

Work on RF superconducting linacs is in progress at Frascati INFN Labs and the LISA project is a first step in this field. Beside the construction of LISA, we have begun a superconducting cavity measurement program, to increase our knowledge and practice in such a matter.

Tuning of resonant cavities is a well-known topic for people working on particle accelerator RF systems. In calculations, cavities are often presented as lumped resonators, but they can reach Q-factor values several orders of magnitude greater than in real R-L-C networks. Then, without a frequency lock system, the resonance condition imposed at a certain instant would be lost during the operation as result of either temperature variations or source frequency drift.

Such a problem becomes more critical in superconducting cavities, even if practical Q-factor values can be reduced by orders of magnitude by the generator coupling that has to match the beam loading whenever the cavities are inserted on accelerators.

Beam loading has also a detuning effect and the resonance condition must be restored by means of some mechanical systems, i.e. pistons or geometrical variations of the cavity boundary as the frequency of the RF generator is fixed.

On the contrary, during the preliminary RF tests on a superconducting cavity, it is possible to keep the tuning condition acting directly on the master RF generator frequency; this is done by a voltage applied through an auxiliary port of the frequency synthesizer. Then in such a case it is convenient to use electronic tuning systems rather than electro-mechanical ones, because the former are faster, simpler and cheaper.

Finally we have to keep in mind that, in testing superconducting cavities outside accelerating structures, we are mainly interested in Q_0 measurements which are easily done only if the cavity and the RF source are not very much overcoupled, i.e. only if the loaded and unloaded quality factors Q_L and Q_0 are of the same order of magnitude. If this is the case we have to handle a resonator with a very narrow bandwidth.

In this paper we present a mathematical model for a frequency lock system of the latter kind essentially based on the linear system feedback theory; it should be clear that the principles exposed here are still valid in the case of an electro-mechanical tuning system provided that we have the functional equations of the mechanical sub-system in order to obtain a mathematical description of the whole system. Phase lock systems are also described by means of similar models.

Anyway we want to point out here that a clear picture of the behaviour and a correct mathematical description are the essential keys to develop stable feedback systems having both high loop gain and wide bandwidth.

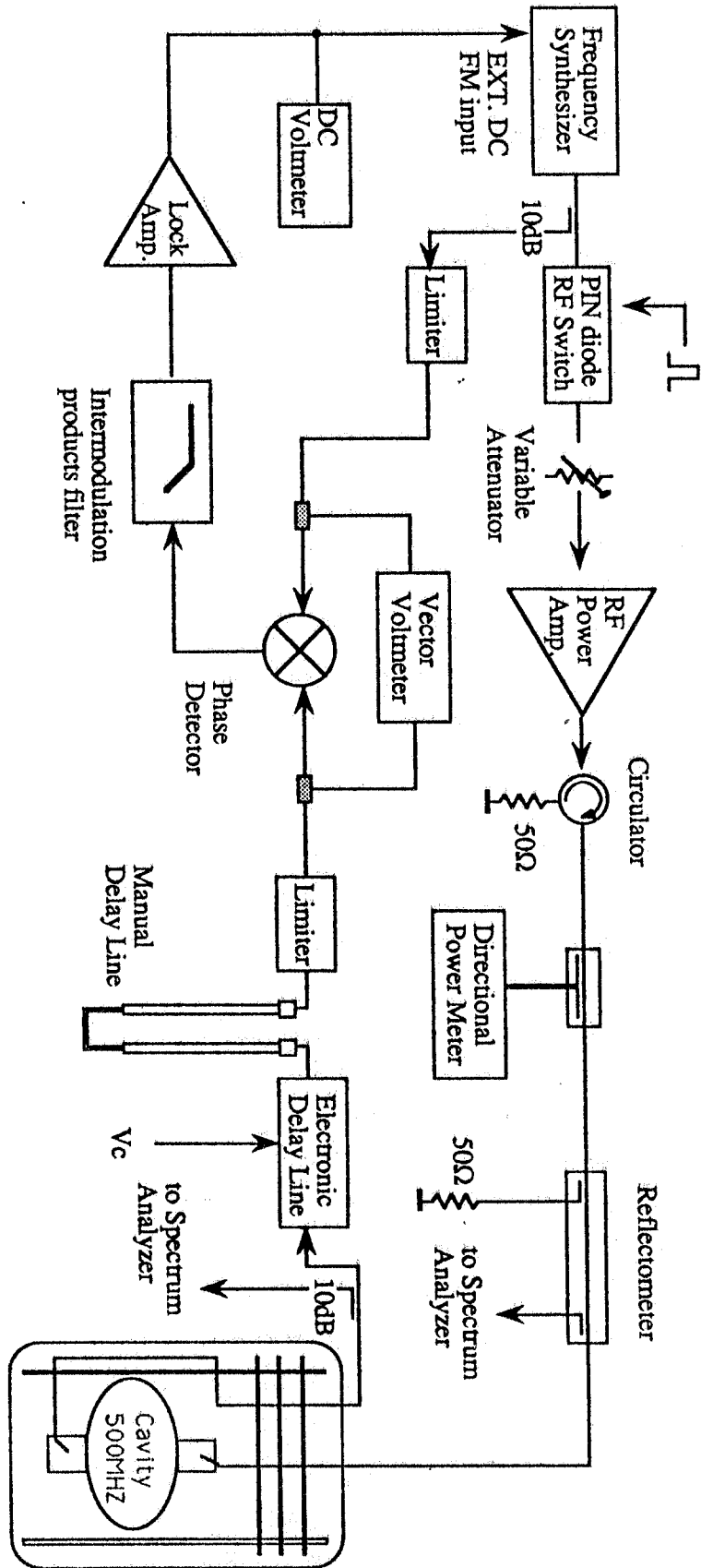

Fig. 1: Control electronic equipment for superconducting cavity RF tests

2. Cavity RF Test System

A typical block diagram for Q_0 measurements on superconducting cavity is presented in Fig. 1. This is also the instrumental configuration we generally use at LNF for this sort of test.

The RF is switched "on" and "off"; looking at the time discharge constant of transmitted power it is possible to measure the loaded quality factor Q_L while from the reverse power pattern we can calculate the coupling factor β between RF source and the cavity itself.

From these two data we can calculate the unloaded quality factor Q_0 as:

$$Q_0 = Q_L(1 + \beta) \quad (1)$$

In order to obtain a formal model of the frequency lock system a preliminary and informal analysis may be very useful.

The operating principle is quite simple. In fact every frequency drift is detected looking at the phase difference between incident and transmitted waves; we remind that in this case transmitted vs. incident relation is given by the transfer function of a high Q resonator, whose phase is very sensitive to input frequency variations around the resonance.

The detected phase error signal is amplified and processed by a dedicated lock amplifier and then connected to the EXT DC FM input gate of the frequency synthesizer.

If the system is locked, i.e. if the sign of the overall loop gain is set negative and every device is held in its linear operating range, every frequency drift will induce an equal variation of the source frequency as result of the loop reaction.

This is because the high gain error amplifier sets the source frequency at the exact value corresponding to a null DC output of the phase detector; using a Double Balanced Mixer as phase detector, the phase difference that causes a null output is about 90 degrees.

Two questions arise from this first rough analysis. The first one is how to close the loop starting from an unlocked condition; the second one is how to design a lock amplifier in order to obtain a stable system with the highest loop gain.

This paper intends to answer extensively to the second question; referring to the first one we like just to point out that this "first locking problem" is strictly related to the non-linear device behaviour and it is strongly dependent on the overall open loop phase offset at the phase detector. There are some offset values that correspond to a self-consistent saturated state of the loop; for other values such a steady state cannot exist. These last values are those that certainly force the system in the lock state and they may be reached experimentally acting on a 360 degrees phase shifter.

Anyway, the subject of how to condition the system to force it automatically in the lock state is a very interesting one, especially when pulsed RF operation is required.

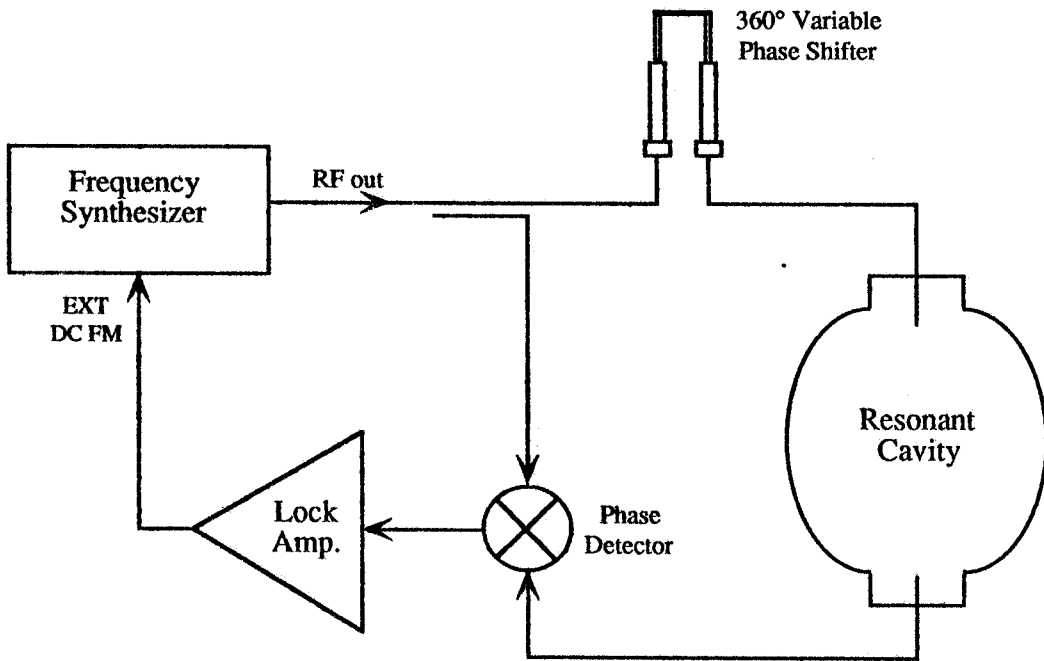

Fig. 2: Simplified block diagram of the lock system

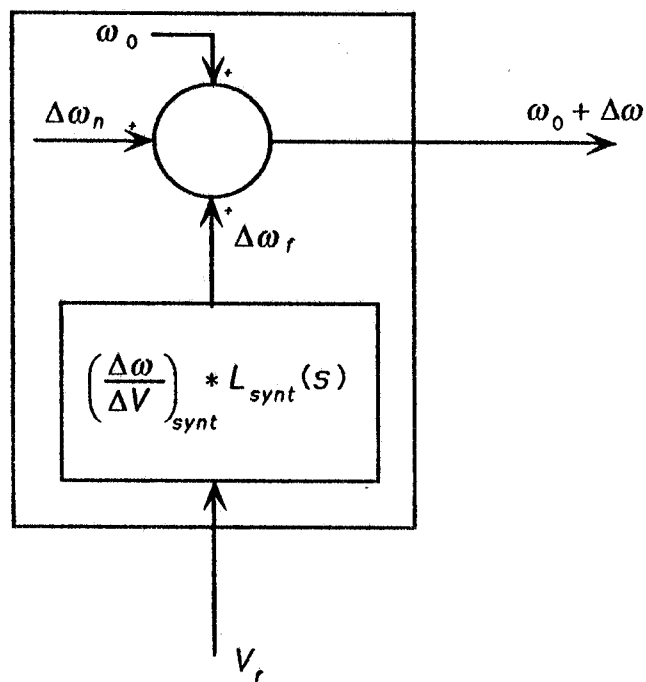

Fig. 3: Frequency synthesizer model

3. Detailed Block Diagram Analysis

In Fig. 2 a simplified block diagram of the lock system is presented; we have to analyze the behaviour of the main blocks and describe them by means of appropriate mathematical operators.

Let's start with the frequency synthesizer. In the arrangements of Figs. 1 and 2 the frequency synthesizer represents both the master generator and the active device of the feedback system; in fact its EXT DC FM gate is the terminal element of the feedback chain.

A detailed model of the frequency synthesizer is presented in Fig. 3. It's possible to identify two sections in it; the first one is a block describing how a control signal is transformed in a frequency deviation at the main output; the second describes the main frequency value as result of three distinct contributions.

In such a picture the first contribution is given by the preset value ω_0 and this must be thought exactly equal to the cavity resonance frequency at every time; a second contribution $\Delta\omega_n$ includes every open loop noise term, i.e. the slow drifts and the periodic variations of the main frequency with respect to the cavity resonance; the third one $\Delta\omega_f$ is the feedback term coming from the EXT DC FM input.

We have to pay attention that the control signal at this last gate is transformed in a frequency deviation not only by a constant coefficient equal to the DC gate sensitivity $(\Delta\omega/\Delta V)_{synt}$ but that the gate is also bandlimited; we take account of this introducing an operator L_{synt} in the transformation block corresponding to a low-pass transfer function in the Laplace s variable domain.

We have carefully measured this transfer function for the HP 8663A synthesizer, which is our master generator: we have found a double pole in the region between 200 and 500 KHz.

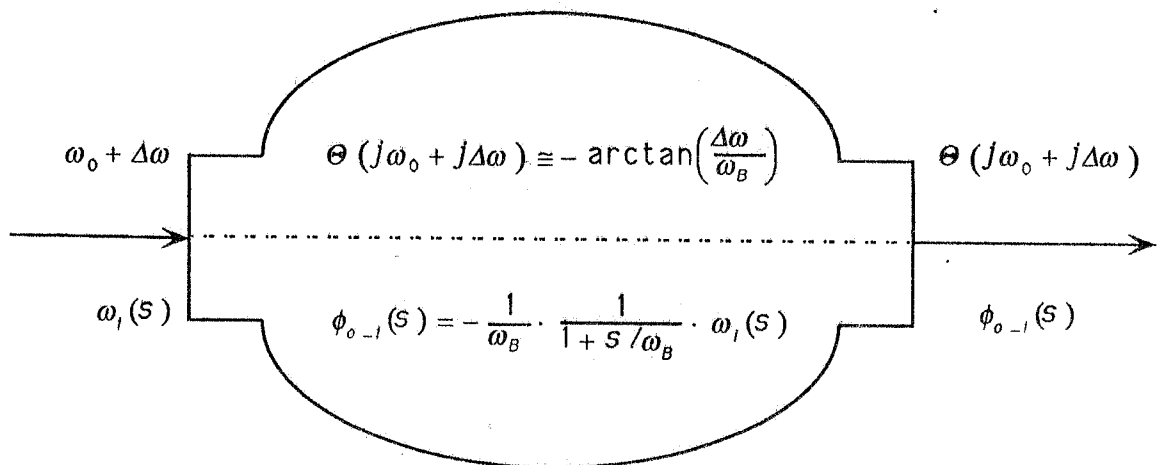

Fig. 4: Resonator model for the frequency lock system analysis

In Fig. 4 is sketched a model of the resonator from our point of view. Here we remind that the transfer function of transmitted vs. incident voltages in this kind of system is given by:

$$T(s) = A \frac{s/\omega_0 Q_L}{(s/\omega_0)^2 + s/\omega_0 Q_L + 1} \quad (2)$$

The phase of this transfer function in the Fourier $j\omega$ domain is given by:

$$\Theta(j\omega) = \arctan \left[Q_L \frac{1 - (\omega/\omega_0)^2}{\omega/\omega_0} \right] \quad (3)$$

For frequencies close to the resonance we may approximate eq. 3 as follow:

$$\Theta(j\omega_0 + j\Delta\omega) \simeq -\arctan(\Delta\omega/\omega_B) \quad (4)$$

where $\omega_B = \omega_0/2Q_L$ is the cavity half bandwidth, an often recurring parameter in describing the resonator response at exciting frequencies close to its own resonance.

As shown in appendix, the relative approximation of eq. 4 is of the same order of $\Delta\omega/\omega_0$ and this appears very adequate in our analysis where the frequency noise spectrum is located many orders of magnitude below the resonance frequency.

By means of eq. 4 we are able to predict the resonator behaviour in presence of very slow frequency drift. Nevertheless if we are dealing with the resonator behaviour in presence of low and relatively fast frequency noise, we have to make the harmonic analysis of the output signal.

On the basis of eq. 2 it's easy to demonstrate that an input small phase noise ϕ_i is transformed in an output term ϕ_o according to a law given in the s domain by the following transfer function:

$$L_c(s) = \frac{\phi_o(s)}{\phi_i(s)} = \frac{1}{1 + s/\omega_B} \quad (5)$$

corresponding to a low pass transfer function having a single pole at the half bandwidth frequency ω_B . As eq. 5 holds for amplitude variations as well, it is easy to show that ω_B is just the reciprocal of the cavity filling time, a well-known parameter in describing cavities.

For superconducting cavities this value of ω_B may be less than 1 Hz.

Reminding that phase and frequency noise are related by:

$$\phi(s) = \omega(s)/s \quad (6)$$

we finally obtain:

$$\phi_{o-i}(s) = \phi_o(s) - \phi_i(s) = -\frac{1}{\omega_B} \frac{1}{1 + s/\omega_B} \omega_i(s) \quad (7)$$

which relates the phase noise detected to the frequency noise in the system.

The last loop device we have to discuss is the phase detector. The nature of this object is such that it shows a 2π periodic output characteristic; then it is linear only over a limited phase range. The most suitable and common device for RF phase detection is the Double Balanced Mixer (DBM). It is a three ports, general purpose RF device; when used as phase detector it generally shows a sinusoidal characteristic as follow:

$$V_d = - \left(\frac{\Delta V}{\Delta \phi} \right)_{det} \cos(\Delta \phi_{1-2}) \quad (8)$$

It is possible to obtain a better linearity paying close attention to the input signal levels and output load impedance; in this case the device can have a triangular characteristic .

An output low pass filter is required for correct operation but its cutoff value can be set so high that we can neglect it without damage in the present analysis . So when the phase difference between the two input signals is made by an offset stable term and a superimposed small time varying contribution, the first one sets the device working point and its sensitivity for the response to the second term.

Further we have to remark that the phase detector characteristic has two regions having opposite slopes so that a shift of the working point can also change the overall sign of the reaction chain. That may put the system into positive feedback, i.e. in failure conditions.

A block diagram of the lock system showing the main components together with their mathematical representations is drawn in Figs. 5 and 6. In the next section we will obtain the transfer function of such a system and discuss the lock amplifier design in order to reach the best performance in loop gain and bandwidth.

4. Lock System Transfer Function

In this section we describe the loop performances treating the static and dynamic problems separately; this is the reason why we present two equal block diagrams in Figs. 5 and 6. In the first one the static relations are showed, i.e. the relations holding whenever the system parameters change very slowly with respect to cavity filling time, the longest response time of the whole system.

Looking at the block diagram of Fig. 5 we can observe that, by means of the high dc gain lock amplifier, the dc lock condition imposes a null dc output at the phase detector and the phase difference $\Delta \Phi_d = \pi/2$ at the input gates.

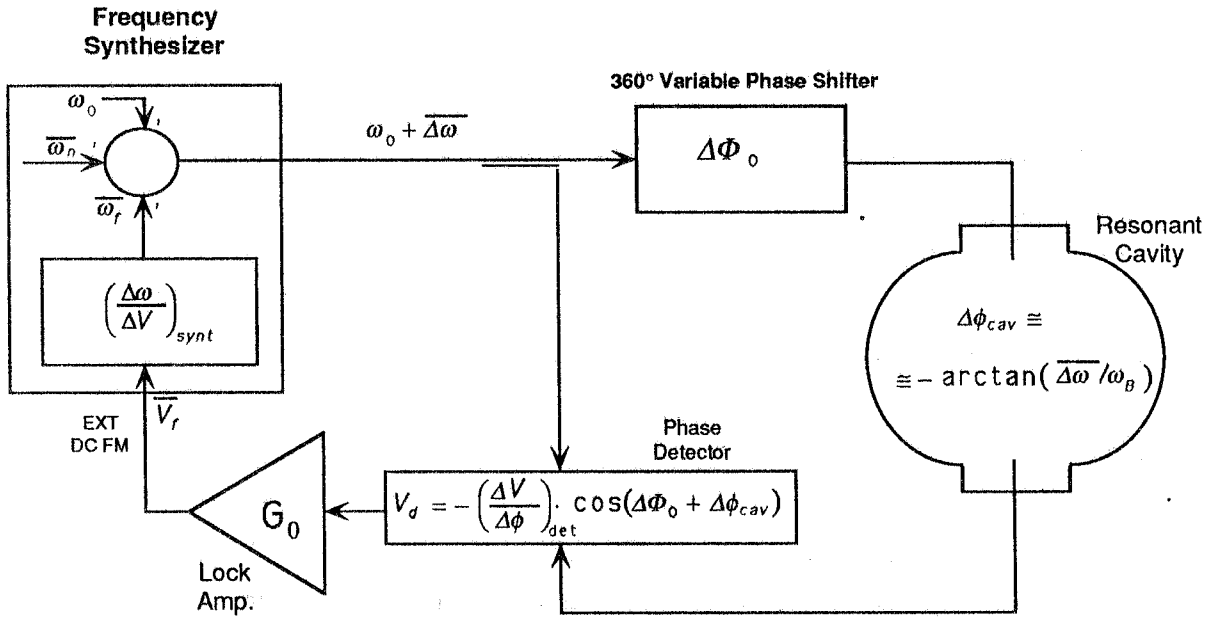

Fig. 5: Static model of the frequency lock system

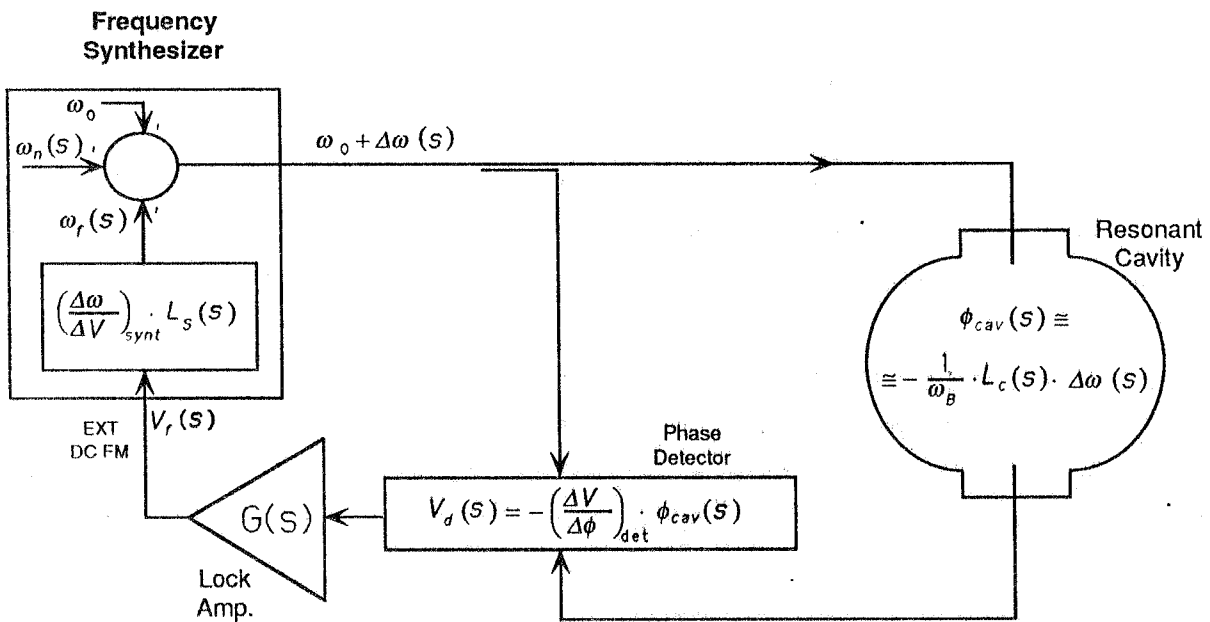

Fig. 6: Dynamic model of the frequency lock system

Then we have:

$$\Delta\Phi_d = \Delta\Phi_0 + \Delta\Phi_{cav} = \pi/2 \quad (9)$$

that, together with eq. 4, gives:

$$\Delta\Phi_0 - \arctan\left(\frac{\overline{\Delta\omega}}{\omega_B}\right) = \pi/2 \quad (10)$$

If $\Delta\Phi_0$ is set in the $(0, \pi)$ range, eq. 10 will have a solution given by:

$$\overline{\Delta\omega} = \omega_B \tan(\Delta\Phi_0 - \pi/2) \quad (11)$$

Otherwise eq. 10 will admit no solution and the system will never reach the lock condition.

The last statement together with eq. 11 show us that the overall phase $\Delta\Phi_0$ control is the crucial operation in order to keep lock state available; further setting experimentally the $\Delta\Phi_0$ value as close as possible to $\pi/2$ the operating frequency $\omega_0 + \overline{\Delta\omega}$ may be held well inside the resonance bandwidth, it does not matter how narrow it may be.

In such a condition, with $\overline{\Delta\omega} \simeq 0$, the dc level of the feedback voltage at the EXT DC FM gate $\overline{V_f}$ will automatically produce a frequency variation $\overline{\Delta\omega_f}$ equal and opposite to the frequency difference $\overline{\omega_n}$ between cavity resonance and master generator preset. This means:

$$\overline{\Delta\omega} \simeq 0 \Rightarrow \overline{\omega_n} + \overline{\Delta\omega_f} \simeq 0 \Rightarrow \overline{V_f} \simeq -\frac{\overline{\Delta\omega_n}}{\left(\frac{\Delta\omega}{\Delta V}\right)_{synt}} \quad (12)$$

As a conclusion, a perfect tuning is then certainly attainable by means of the 2π continuous phase shifter suitably inserted in the loop chain. However this will be true only if the lock system is intrinsically stable. Let's finally start the discussion of this last topic.

From the dynamic point of view the system is described in Fig. 6.

The small noise signals are presented in the Laplace s domain in order to discuss the stability using the ordinary Bode and Nyquist criteria; further in this case the dynamical behaviour of the various blocks is simply described by some functions of the complex variable s thought as multiplication operators.

Looking at Fig. 6 we have the following relation:

$$\begin{aligned} \Delta\omega(s) &= \omega_n(s) + \omega_f(s) = \\ &= \omega_n(s) - \left(\frac{\Delta\omega}{\Delta V}\right)_{synt} \left(\frac{\Delta V}{\Delta\phi}\right)_{det} \frac{1}{1 + (\overline{\Delta\omega}/\omega_B)^2} \frac{1}{\omega_B} L_{synt}(s) L_c(s) G(s) \end{aligned} \quad (13)$$

From eq. 11 we know that the

$$\frac{1}{1 + (\Delta\omega/\omega_B)^2}$$

factor can be experimentally set very close to 1. Then the overall closed loop transfer function may be expressed by:

$$T_{closed}(s) = \frac{\Delta\omega(s)}{\omega_n(s)} = \frac{1}{1 + \frac{1}{\omega_B} \left(\frac{\Delta V}{\Delta\phi} \right)_{det} \left(\frac{\Delta\omega}{\Delta V} \right)_{synt} L_{synt}(s) L_c(s) G(s)} \quad (14)$$

This last equation relates the residual frequency noise $\Delta\omega(s)$ in the system to the open loop frequency error $\omega_n(s)$.

The open loop transfer function is then given by:

$$T_{open}(s) = \frac{1}{\omega_B} \left(\frac{\Delta V}{\Delta\phi} \right)_{det} \left(\frac{\Delta\omega}{\Delta V} \right)_{synt} L_{synt}(s) L_c(s) G(s) \quad (15)$$

Following the Bode stability criterion we know that a feedback system is intrinsically stable if its open loop transfer function crosses the 0 dB axis (unity gain) with a phase less than π . This is the case whenever the 0-cross frequency ω_{0dB} is such that the difference between the number of poles and number of zeros on its left is exactly 1.

Reminding the pole configuration of our system, we have to design an overall transfer function crossing the 0 dB axis in the 100 KHz region; in this case the only pole lying on ω_{0dB} left is the cavity bandwidth pole included in the $L_c(s)$ term of the eq. 15.

There are many possible choices of lock amplifier main parameters included in the $G(s)$ term. Testing a superconducting cavity in the vicinity of critical coupling, the ω_B pole is located at a so low frequency that an ω_{0dB} of about 100 KHz will produce a very high dc gain, as reported in Fig. 7. In this case a lock amplifier having a flat Bode plot will be adequate in order to set the right dc gain without perturbation of the overall transfer function shape. Notice that the bandwidth of such an amplifier must be larger than ω_{0dB} to prevent loop instability.

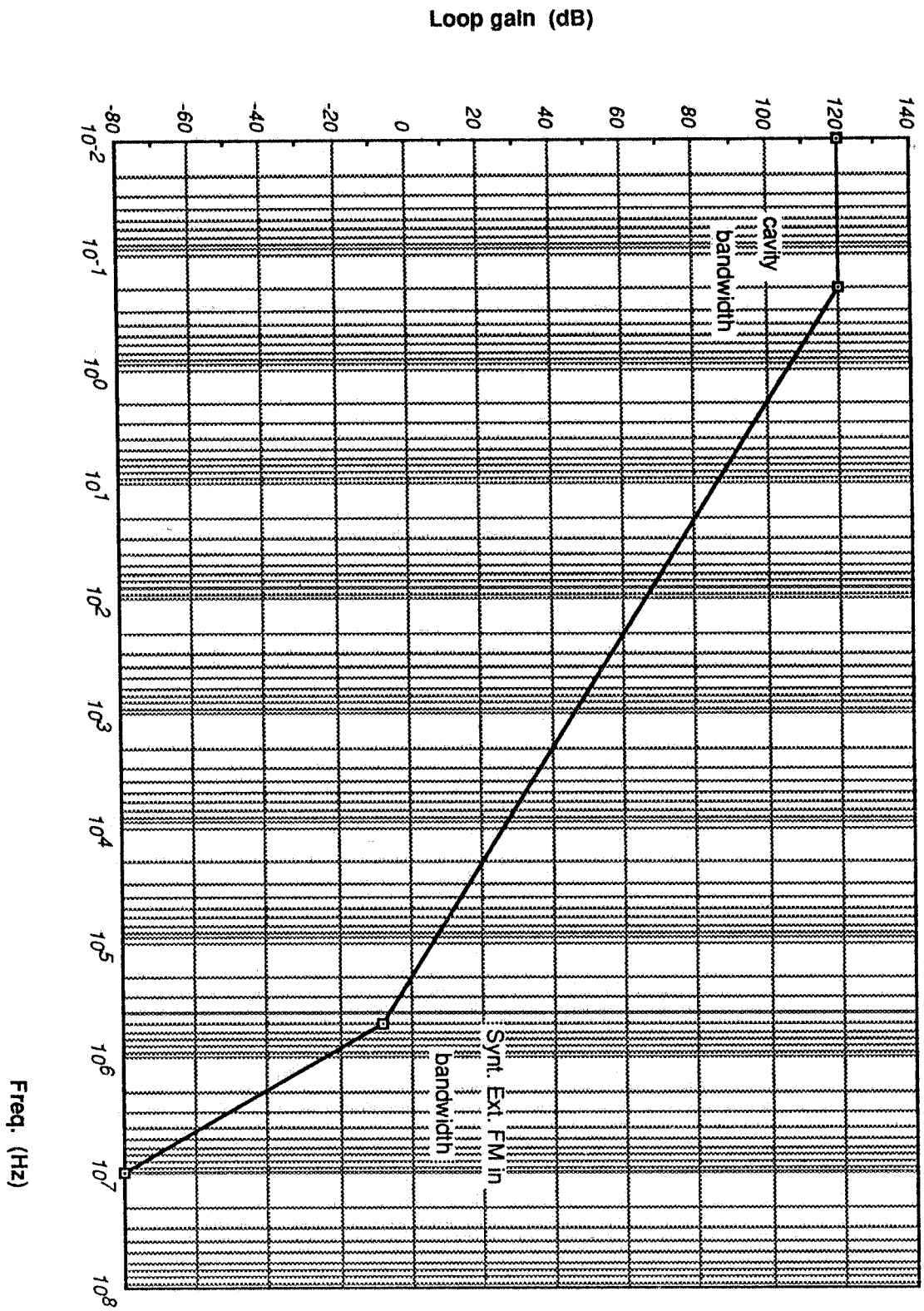

Fig. 7: Bode plot of the frequency lock system

In the case of strongly overcoupled superconducting cavities or normal conducting ones the bandwidth pole ω_B will assume higher values with respect to the previous case. Because the condition $\omega_{0dB} \simeq 100$ KHz still holds, a too low dc loop gain may result. This failure may be overcome by means of a pole-zero compensating lock amplifier; in fact if the lock amplifier transfer function is of the following kind:

$$G(s) = G_0 \frac{1 + s/\omega_B}{1 + s/\omega_p} \quad (16)$$

with $\omega_p \ll \omega_B$, then a much higher dc loop gain is attainable.

Finally, if a wider loop bandwidth ω_{0dB} were necessary, a more fine compensation will be required. In this case the lock amplifier transfer function $G(s)$ must also compensate the poles that actually limit the ω_{0dB} value with the same number of equal zeros. This may be a difficult operation because is not easy to develop stable amplification stages having a "dominant" zero, i.e. a zero located at a frequency considerably lower than everyone of their poles. Furthermore the number and location of unwanted poles are often not precisely known.

The situation may be evaluated from time to time; anyway in many cases such a compensation is not needed.

CONCLUSIONS

It is clear from the above analysis that there are two fundamental keys in developing high performance and reliable control loops. The first one is the loop working point control, i.e. the dc analysis of the problem. We have to introduce the conditions which allow the system to work with all its elements in a sensitive and linear region of their operating range at every time.

Second we have to take account of the dynamical response of each element writing its relative transfer function and to build a suitable lock amplifier in order to reach the design goals.

If the dynamical analysis of the system is well done, this last operation will be a simple exercise of electronics circuit design in Laplace s domain.

Appendix

Here we only want to stress the passage from eq. 3 to eq. 4 for the sake of the clearness.

If we take:

$$\omega = \Delta\omega + \omega_0$$

supposing $\Delta\omega \ll \omega_0$ it's easy to demonstrate that eq. 1 reduces to:

$$\Theta(j\omega_0 + j\Delta\omega) \simeq -\arctan \left[\frac{\Delta\omega}{\omega_B} \left(1 + O(\Delta\omega/\omega_0) \right) \right] \quad (1a)$$

where $O(\Delta\omega/\omega_0)$ is a quantity of the same order of $\Delta\omega/\omega_0$.

Now, since the following relationship always holds:

$$\frac{\arctan[x(1 + \alpha)] - \arctan(x)}{\arctan(x)} \leq \alpha \frac{x}{\arctan(x)} \frac{1}{1 + x^2} \leq \alpha \quad (2a)$$

it is well shown that eq. 4 approximates eq. 1a (and then eq. 3) with a relative error of the same order of $\Delta\omega/\omega_0$.

As we deal with a noise spectrum not wider than lock bandwidth (less than 1 MHz) over a carrier frequency of some hundreds MHz, the relative error in eq. 4 is always less than 1 %.

References

Papoulis: "Circuits and Systems. A modern approach" Holt-Saunders International Editions

Gray-Mayer: "Analysis and design of analog integrated circuits" Wiley

Emmanuel-Leff: "Introduction to feedback control system" Mc Graw-Hill

Taub-Shilling: "Principle of communication systems" Mc Graw-Hill