

To be submitted to
Nuclear Instr. & Meth.

ISTITUTO NAZIONALE DI FISICA NUCLEARE
Laboratori Nazionali di Frascati

LNF-86/4(P)
24 Gennaio 1986

G.Battistoni, G.Bencivenni, P.Campana, B.D'Ettorre Piazzoli,
P.Laurelli, G.Mannocchi and P.Picchi:

A HIGH VOLTAGE NETWORK FOR STREAMER TUBES

A HIGH VOLTAGE NETWORK FOR STREAMER TUBES

G.Battistoni, G.Bencivenni, P.Campana, B.D'Ettorre Piazzoli,
P.Laurelli, G.Mannocchi, P.Picchi.

Laboratori Nazionali dell'INFN, Frascati, Italy

Abstract

We have studied a high voltage network which allows the simultaneous readout of strips and pads for the streamer tubes of the ALEPH hadron calorimeter. The mechanisms of pulse propagation in streamer tubes are discussed, together with the results of experimental tests made with the designed high voltage network configuration.

1.Introduction

The ALEPH hadron calorimeter¹ makes use of electrodeless streamer tubes with resistive cathode^{2,3}. The calorimeter is an integrated system for hadron and muon identification.

Shower energy is measured by measuring the charge induced by streamers on external planar electrodes (pads) arranged in towers pointing to the interaction region. Muons are identified by tracking through the iron, using the digital readout of pick-up strips parallel to the wires; in addition a double layer of tubes, located at the end of the calorimeter and equipped with a bidimensional readout (longitudinal and orthogonal strips), provides a space point for tracking particles escaping the iron.

The structure of the tubes is similar to the one developed for the Mont Blanc experiment⁴. The basic element is an 8-cell open profile made of extruded PVC, coated with graphite (fig. 1a). Unlike the Mont Blanc experiment, the ALEPH hadron calorimeter has coverless tubes, where three sides of the square cross section are coated with graphite, the fourth side being left electrodeless. This allows for a much simplified construction without changing the performances³.

The 8-tube element is enclosed in an extruded PVC chamber, closed with PVC end caps, where the gas, wire and cathode connections are inserted.

The longitudinal and orthogonal pick-up strips consist of aluminum ribbons attached on a PVC sheet, with an aluminum ground sheet on the other side and a standard connector at one end, to which a readout card is directly connected (fig. 1b). The signal on longitudinal strips is identical in shape to that on the wires with an amplitude of $\sim 15 \text{ mV}/50 \Omega$ (fig. 2a and 2b). Pads are made of two conductive sheets (either copper or aluminum) separated by a dielectric sheet. In the case of the ALEPH barrel hadron calorimeter the pad dimensions are $\sim 20 \times 20 \text{ cm}^2$. In fig. 2c the induced signal on a pad is shown, showing the typical integration of the original pulse due to the capacitance of the readout pad discharging through the 50Ω load.

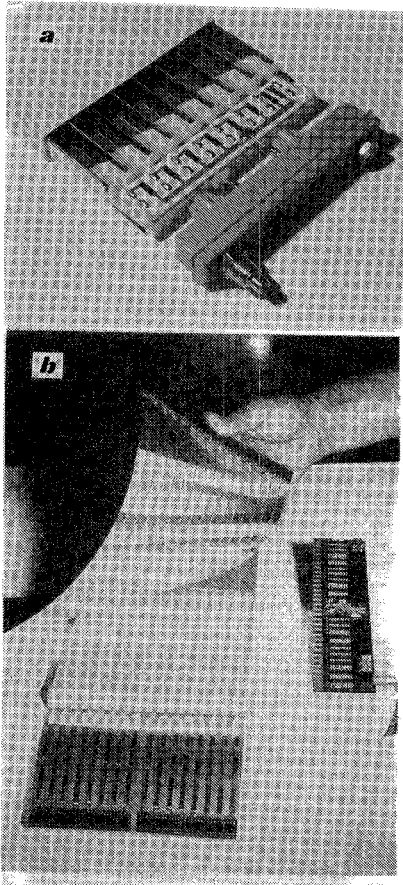

Fig. 1 - a) The geometrical structure of coverless plastic streamer tubes. b) Two 8-tube modules with x and y strips and digital readout card.

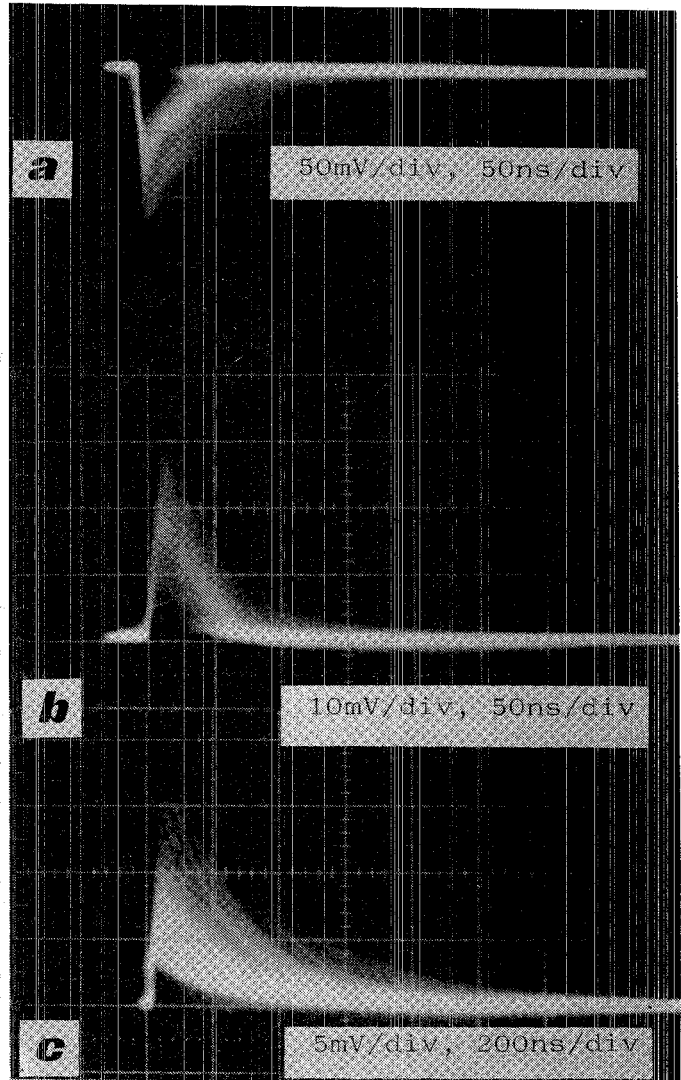

Fig. 2 - Typical streamer pulses on 50Ω load from wires (a), strips (b) and pads (c) for a $9 \times 9 \text{ mm}^2$ cell, 100 m wire, $C_{\text{pad}} \sim 4 \text{ nF}$, Ar+Iso butane 1+3, H.V.=4.5 kV.

The simultaneous readout of strips and pads, as designed in the ALEPH hadron calorimeter, needs an adjustment of the electrical constants of the system. In this work we discuss the design for the H.V. network and for the readout of the tubes.

2. Pad and strip readout

We want briefly to recall the basic mechanism of pulse induction and propagation along longitudinal strips ⁵.

At our lengths (several meters), due to the streamer pulse duration of ~50 ns, wires and strips must be considered as transmission lines. When a streamer is generated, the wire-strip line is at first excited, while the strip-ground line is shielded by the strip itself. The current generated by the streamer must reach one end of the line before being injected into the the strip-ground line, to be detected at its end (fig. 3b).

On the contrary, for strips at an angle with respect to the wire, the wire and strip signals propagate simultaneously and independently (fig. 3a).

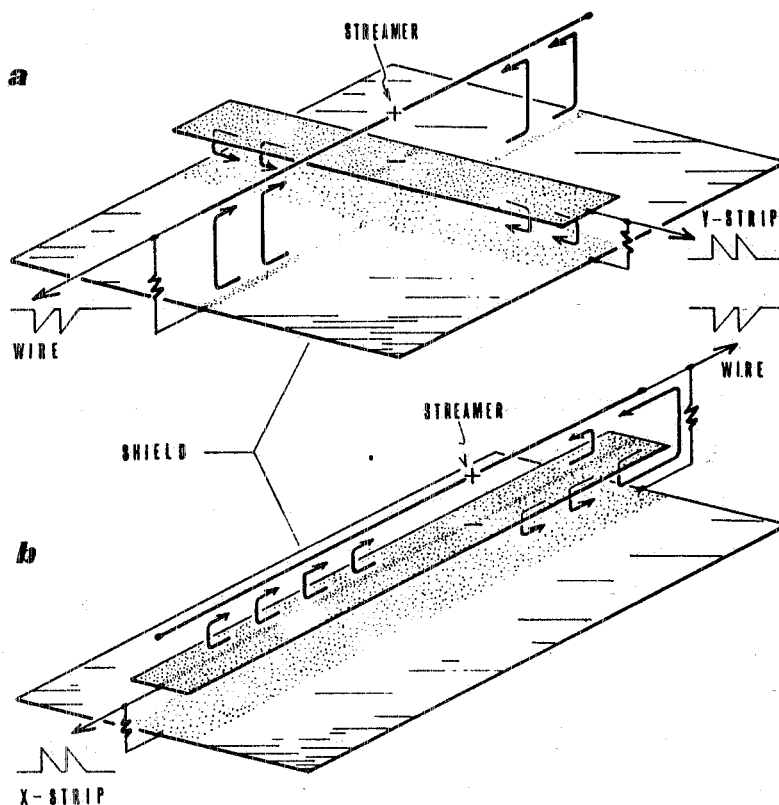

Fig. 3 - Schematic drawings showing propagation of pulses on strips: a) for electrodes at an angle with respect to the wires, the wire and strip signals propagate simultaneously and independently on the wire-ground and strip-ground lines; b) for electrodes parallel to the wires, the current must first flow out of the wire-strip line before being injected into the strip-ground line.

For resistivities above a certain minimum, which depends on the tube geometry³, the cathode does not interfere with the mechanisms of propagation depicted above.

Let us now consider the H.V. network in the case of strip readout only, as it is in the Mont Blanc detector. The anode wire is terminated on one side over its characteristic impedance in order to avoid reflections along the corresponding line: note that for each wire of an 8-tube element, the "ground" is provided by the total capacitance of the other seven wires; each 8-tube is then connected to the H.V. through a current-limiting resistor (fig. 4): each 8-wire group is independent from the others belonging to the same plane.

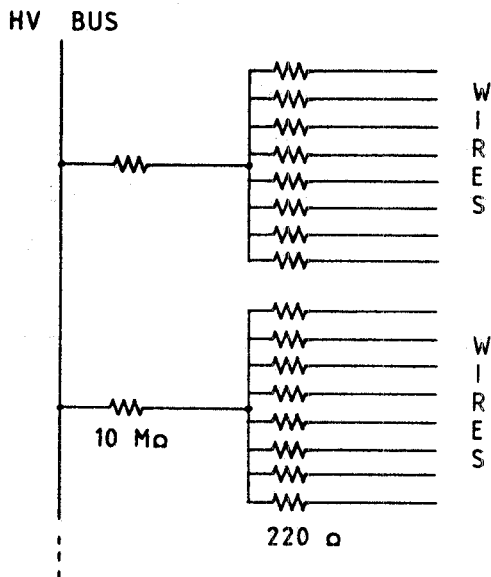

Fig. 4 - The connection of 8-tube elements to the H.V. network in the case of x, y strips readout (Mont Blanc detector scheme).

In this electrical configuration, due to the presence of high impedance toward the H.V. line, the charge flowing out of the hit wire is injected, through the parallel of the matching resistors, into the neighbouring wires: the amount of current per wire is about 1/7 of that generated in the discharge process. Being each wire capacitatively coupled to the strip facing it, a negative signal will be induced on each longitudinal strip of the 8-tube, except the one placed above the hit wire (fig. 5). This signal will sum on the lateral strips with that (positive) due to the local direct charge induction by the streamer. The final effect is to reduce the charge seen by lateral strips, limiting to a negligible fraction the number of cases in which more than one longitudinal strip is fired for orthogonal tracks. With this configuration the mean multiplicity on longitudinal strips is about 1.1 per single orthogonal track.

In the case of plastic streamer tubes equipped with both pad and strip readout, it must be considered that in order to perform the pad readout, the current generated on hit wires must flow out of the wire plane to ground. In fact, if this is not allowed, the current is injected in the adjacent wires giving, by capacitive coupling between wires and pads, negative pulses on the pads standing along the tube profile interested by the discharge process. As in the case of strips, these signals will sum with those (positive) induced on pads by the streamer. This is the case of the H.V.

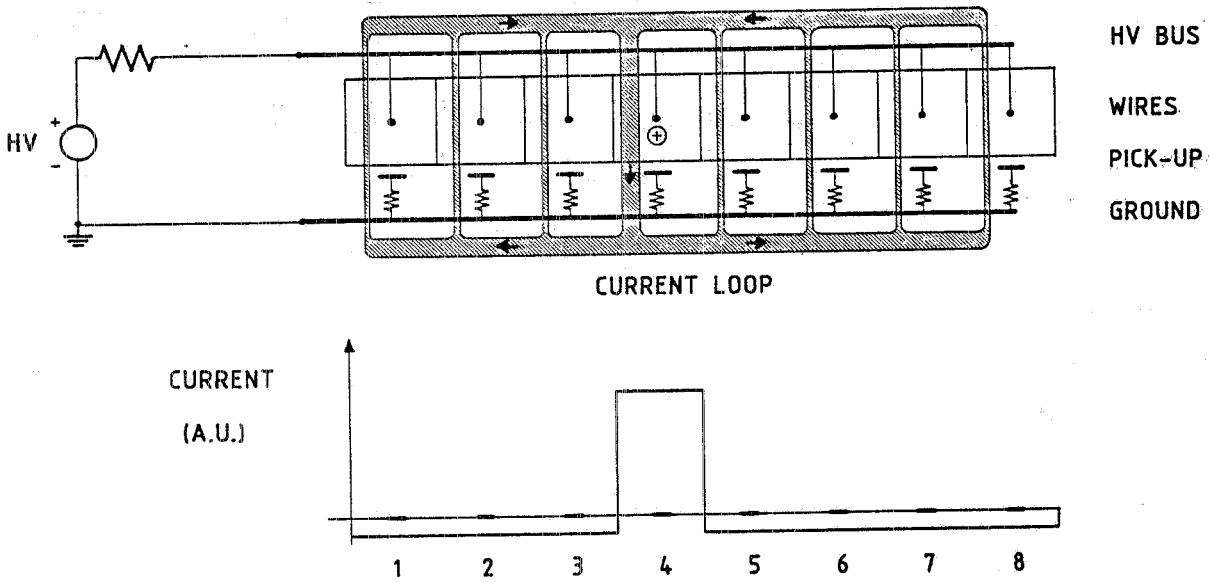

Fig. 5 - Current signal detected on strips in the case of H.V. network of Fig. 4, when the current is not allowed to flow out of the hit wire; current loops close through the parallel of the other seven wires.

network configuration of fig.4, where, due to the presence of a high impedance toward ground (blocking resistor), the sum of the charge collected on pads is null. Only when the induction area is much smaller than the wire plane area, the readout can be performed even in this configuration.

A complete outflow of the current from the wire can be obtained with capacitors (larger than tube capacity) connected to ground (fig. 6). In this case the reduction of multiplicity, originated by the effect of current injection in the nearby wires quoted above, is cancelled: the mean

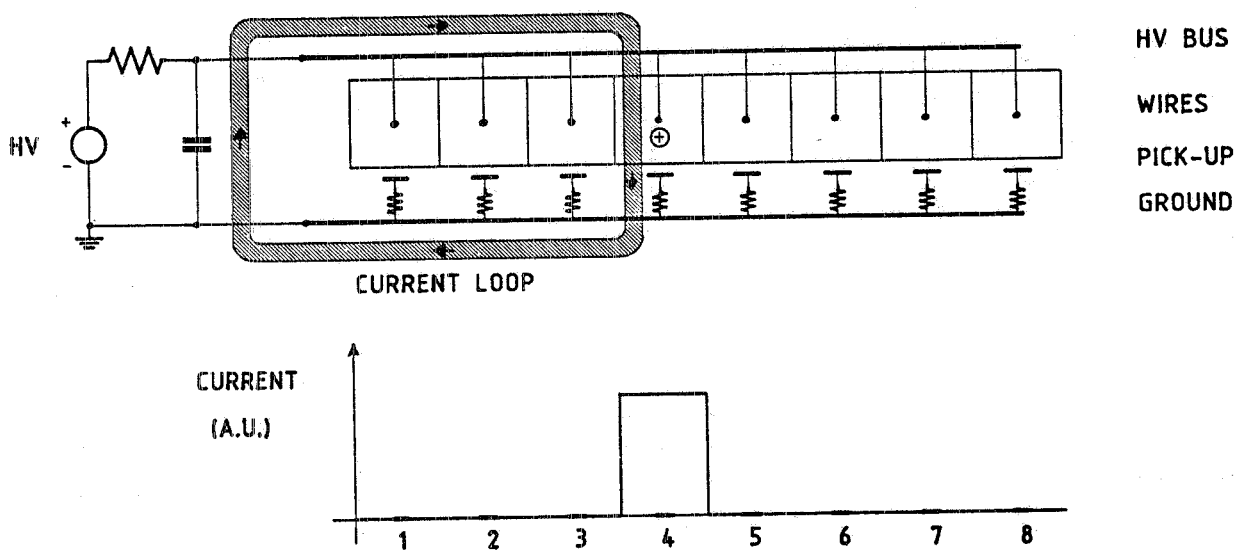

Fig. 6 - Current signal detected on strips when the current from the hit wire outflows to ground through a capacitor: no negative charge is injected into adjacent strips.

multiplicity on strips increases, without affecting the spatial resolution, but reducing the two track separation.

We will call this method of pads and strips readout "constant voltage mode": no negative charge appears on pads adjacent to the hit one (fig. 7a). It must be noticed that the pad readout can be performed also in a "constant charge mode", i.e. when no current is allowed to flow out from the system, if all the wires belonging to one plane are OR-ed and connected together to a single current limiting resistor. In this case, due to the reinjection of a constant negative charge on all pads of the plane, a bipolar ADC should be used in order to measure charges with respect to the new negative value of the pedestal (fig. 7b).

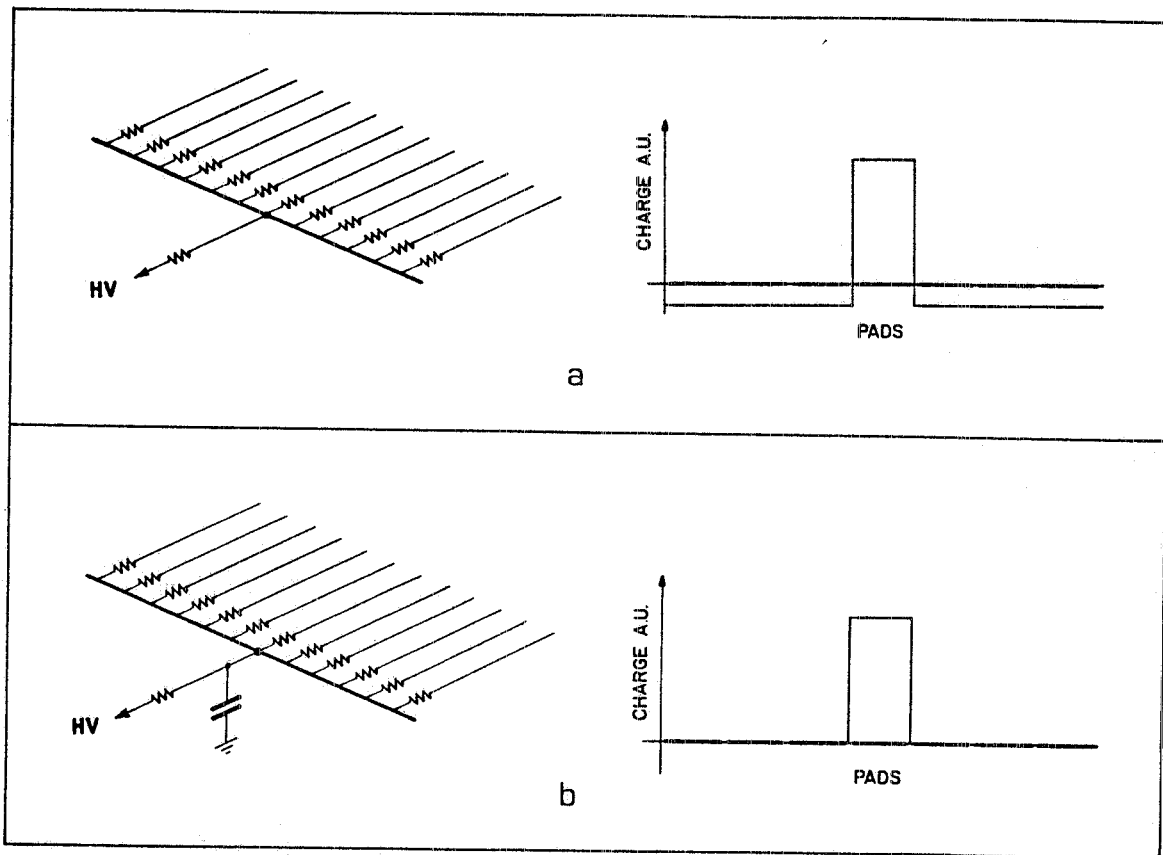

Fig. 7 - Readout possibilities in the case of the connection of all wires belonging to one plane to a single H.V. bus: a) in the constant voltage mode configuration, b) in the constant charge mode configuration.

In order to fulfill these competing requirements, we take advantage of the fact that the time scales of the two readouts (pads and strips) are quite different, and we have developed the readout scheme shown in fig. 8. The readout of the charge collected on pads is performed in about $1 \mu\text{s}$, while the propagation of pulses along wires is completed within 50 ns. With the proposed network the wire current flows to ground with an intermediate time constant (whose value can be tuned by varying the resistor R_g), with injection of negative pulses into adjacent strips only occurring for the

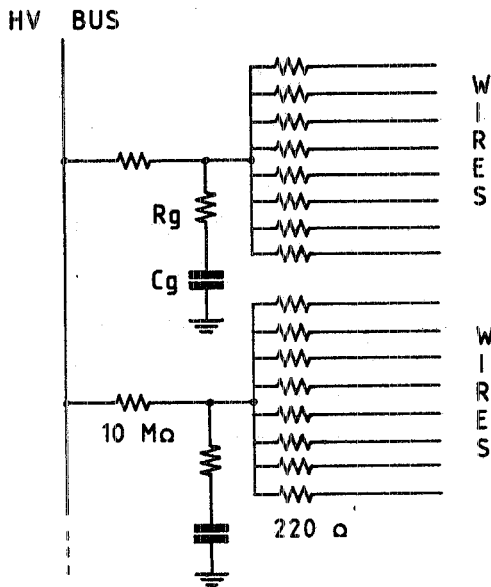

Fig. 8 - The H.V. network design for the readout of strips and pads.

first 100-200 ns. That is, during the digital readout time the system is operated in the constant charge mode, while at the longer charge readout time it is operated in the constant voltage mode.

3. Experimental tests

The experimental set-up consists of two layers of streamer tubes inserted in a telescope of streamer tubes which selects cosmic ray tracks orthogonal to the planes. One layer is made of four 8-tubes (32 wires) 1.5 m long, filled with a Ar+Isobutane (1+3) gas mixture and operated inside the full efficiency plateau.

The layer is equipped with two pads (70 x 33 cm² each, 1.6 mm fiberglass as dielectric, copper as electrodes; C ~ 4 nF) which fully cover one side of the tube plane. On the other side, aluminum strips (4 mm wide, 10 mm pitch) run parallel to the wires, feeding a 32 channels STOS-LeCroy digital card.

The second layer consists of four 8-tubes (32 wires) 3.5 m long, with the same structure described above. These tubes are equipped with two pads (50 x 33 cm² each, 1.6 mm fiberglass, copper electrodes; C ~ 3 nF) which cover partially one side of the tube plane. An aluminum ground sheet covers the residual area. The opposite side is equipped with aluminum strips as for the previous layer.

The telescope defines tracks within 5° with respect to the vertical, pointing only toward the central part of one pad for both layers. The positive charge from the hit pad, and the negative charge from the adjacent pad is readout, together with the signal from the wire, to monitor the total charge produced in the streamer process.

Three measurements have been performed with 1.5 m and 3.5 m long tubes:

- a) the study of the dependence of the hit multiplicity on strips as a function of R_g ;
- b) the test of the R_g dependence from the tube length;
- c) the study of the amount of charge collected on the hit pad as a function of R_g .

Fig. 9a shows the plot of the hit multiplicity on strips, scaled to that obtainable with the wire current fully reinjected (n/n_∞), as a function of the product $R_g C_w$ (where C_w is the wire capacity, about 10 pF per meter of wire) for the two tube lengths. In this representation, the

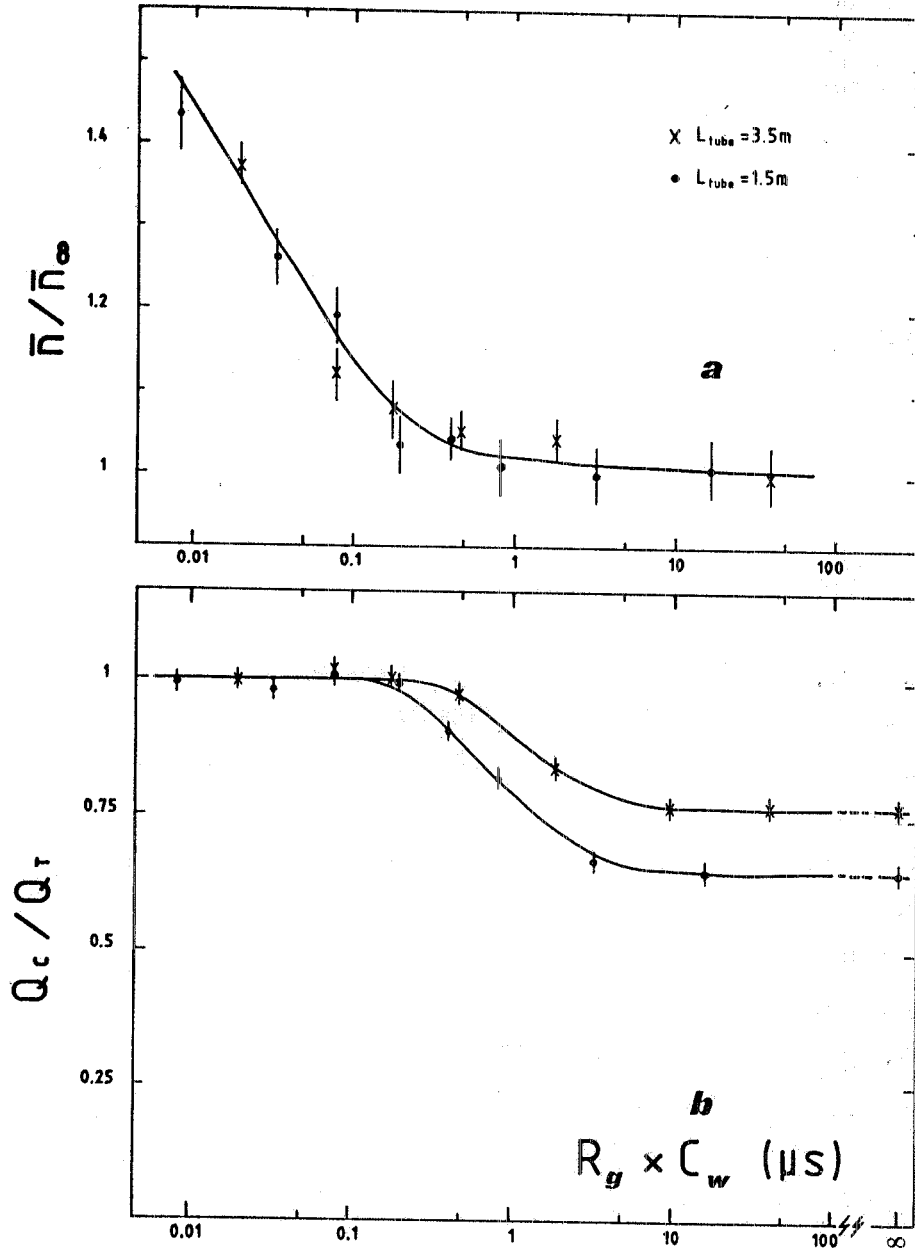

Fig. 9 - a) Plot of the average multiplicity on strips (scaled to that obtained with full reinjection of current, n_∞) as a function of the time constant $R_g C_w$ of the proposed network. b) Plot of Q_c (charge on the hit pad)/ Q_t (charge on hit pad at $R_g=0$) as a function of $R_g C_w$.

experimental data lie on the same curve, showing a $R_g \sim L^{-1}$ law, where L is the length of the tube.

In fig. 9b the plot of Q_c (charge on central pad)/ Q_t (charge on central pad at $R_g=0$) as a function of $R_g C_w$ is shown. It is worth to notice that, even in this measurement, the position of the knee of the two curves is identical, confirming that R_g varies as the inverse of the wire length.

The asymptotic value of Q_c/Q_t reached for $R_g C_w \rightarrow \infty$ (full reinjection of the charge in adjacent wires) is different in the two cases, due to the different geometries of the pads.

From these curves it appears that for any tube length, the chosen value of R_g is not critical. The value of R_g in the case of the tubes of the ALEPH hadron calorimeter (barrel, 7 m length) is about 150Ω .

4. Conclusions

We have pointed out that the strip and pad readout in streamer tubes leads to the conflicting requirements of keeping the multiplicity on strips low and collecting the full charge of streamers on pads.

With the proposed H.V. network the readout of both electrodes is made possible with a moderate increase of hit multiplicity on strips. In this configuration the charge induced by the streamer is fully collected on the hit pad. The values of the electrical constants of the circuit necessary to achieve this operation condition appear to be non critical.

References

- (1) ALEPH Collaboration, CERN/LEPC 83-2, CERN/LEPC 84-15.
- (2) E. Iarocci, Nucl. Instr. and Meth. **217** (1983) 30.
- (3) G. Battistoni et al., Nucl. Instr. and Meth. **217** (1983) 429.
- (4) G. Battistoni et al., LNF Report 85-48, submitted to Nucl. Instr. and Meth.
- (5) G. Battistoni et al., Nucl. Instr. and Meth. **176** (1980) 297.