

ISTITUTO NAZIONALE DI FISICA NUCLEARE
Laboratori Nazionali di Frascati

LNF-84/56(R)
27 Settembre 1984

T. Camporesi : PERFORMANCE OF THE MAC dE/dx SET UP

T. Camporesi: PERFORMANCE OF THE MAC dE/dx SET UP

The MAC experiment, situated at the PEP e^+e^- storage ring at SLAC, has accumulated 75 pb^{-1} since the installation of the electronic extension to read out the specific ionization (dE/dx) for every cell of the central drift chamber (CD).

The goal of the project was to obtain a 3σ separation between high energy electrons lying on the Fermi plateau and pions near the minimum ionization point, i.e. resolution of 20-25% for a ratio plateau/minimum = 1.6.

We describe here the performance of the system under actual data taking conditions and show how we can use it to improve our particle identification.

1.- INTRODUCTION

The MAC detector (Fig. 1a) has been described elsewhere⁽¹⁾. Here we point out only the salient features of the central drift chamber (Fig.1b).

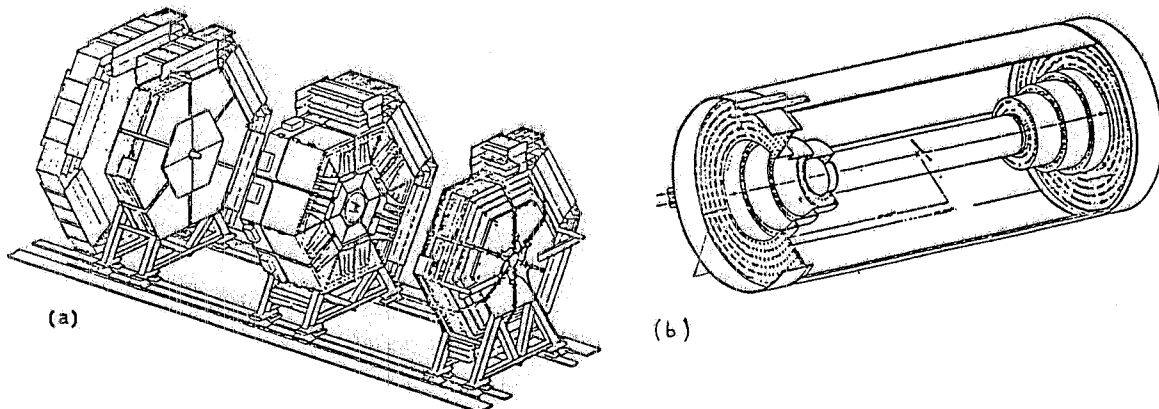

FIG. 1 - a) Artist view of the MAC detector; b) The central drift chamber.

The CD contains 833 drift cells arranged in ten cylindrical layers inside a common gas volume filled with 90% argon, 10% methane. The material between the interaction point and the first active layer amount to 0.036 radiation lengths for normal incidence particles. The CD is inside a solenoidal magnetic field ($B = 5.7$ Tesla). The ten layers are located at equally spaced radii with the innermost layer at 12 cm and the outermost at 45 cm from the beam intersection. Each cell (see Fig. 2a) has two closely spaced sense wires, connected to a differential readout electronics, which measure the drift distance without left right ambiguity. In Fig. 2b is sketched also the structure of the dE/dx readout.

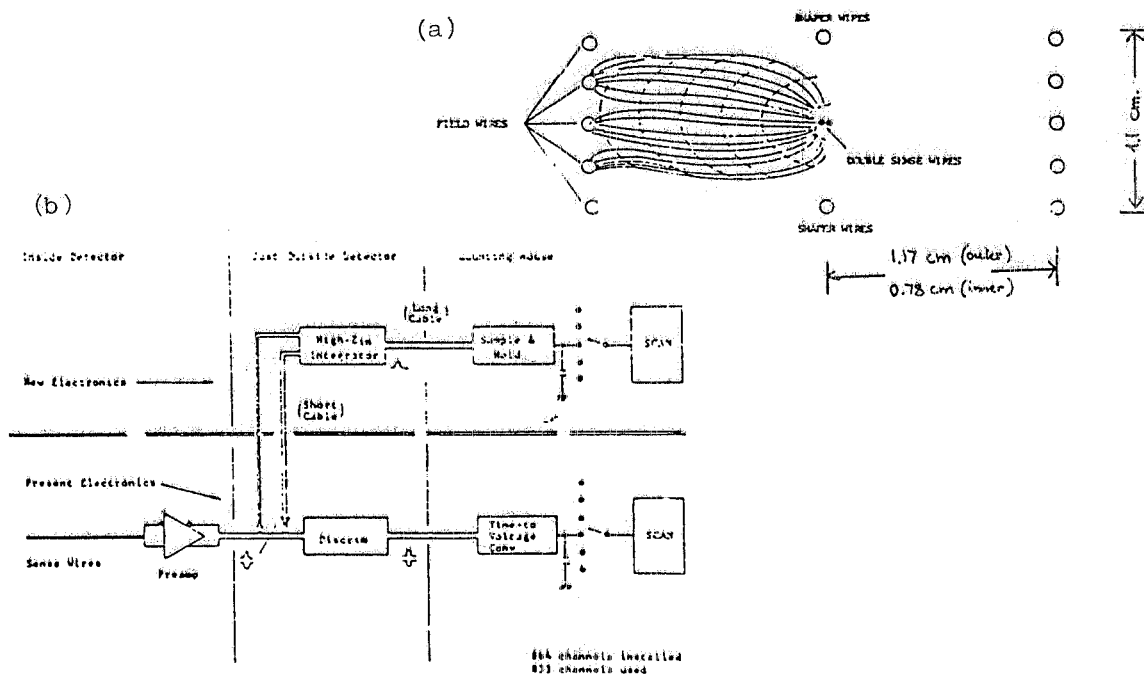

FIG. 2 - a) Structure of a CD cell; b) Sketch of the dE/dx readout.

2.- PERFORMANCE

Each particle passing through the CD is sampled up to ten times. In this study only tracks having at least five samplings are considered (that is 100% of reconstructed Bhabhas and 85-90% of reconstructed multihadrons). Each individual pulse height has to be at least 2 sigmas away from the pedestal to be considered a good sampling. This criteria eliminates all those samples in which the particle goes through the two sense wires releasing

essentially the same amount of ionization on both wires (the geometrical probability is $\approx 2\%$ for uniform illumination). This samples are also removed by requiring consistency of the sign of the pulse height with the sign of the time measured by the TDC system.

The only monochromatic particles⁽²⁾ are electrons and positrons from Bhabha scattering (energy 14.5 GeV), μ pairs and cosmic rays. The electronic gain for each channel is evaluated from the response to a known pulse injected before the preamp, while the gas and cell gains for every channel are evaluated from Bhabha events. This is done for groups of runs totalling $\geq 2 \text{ pb}^{-1}$ (from two to three days of actual running time). The pulse height of every cell is corrected for the particle incident angle, for the azimuthal bending due to the magnetic field (this correction is of the order of a few percent only for low momentum tracks), and for the observed dependency of the integrated pulse height from the distance from the sense wire, i.e. the drift time (Fig.3). The most probable value for

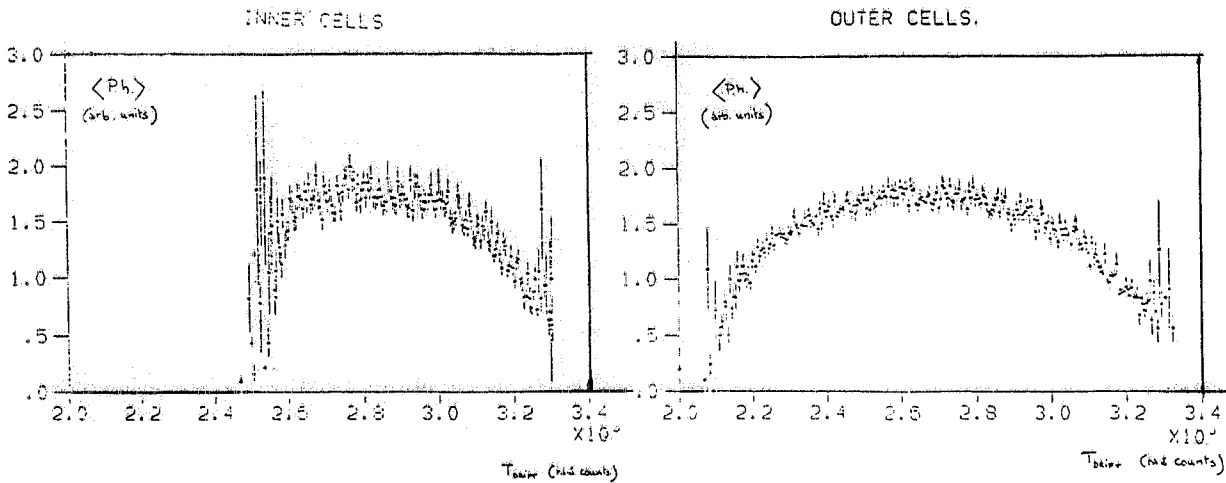

FIG. 3 - Dependence of pulse height on drift time.

the dE/dx for a given track is estimated averaging the smallest 70% of the samplings; 70% has been chosen because it minimizes the discrete jumps due to the limited number of samples. This is becoming a standard technique to eliminate the Landau tail fluctuation of the differential dE/dx distribution in the estimation of the most probable value of the distribution.

Looking at the average dE/dx vs. scattering angle we see no saturation effect, which could show up at large absolute energy loss, i.e. at small angles (Fig. 4).

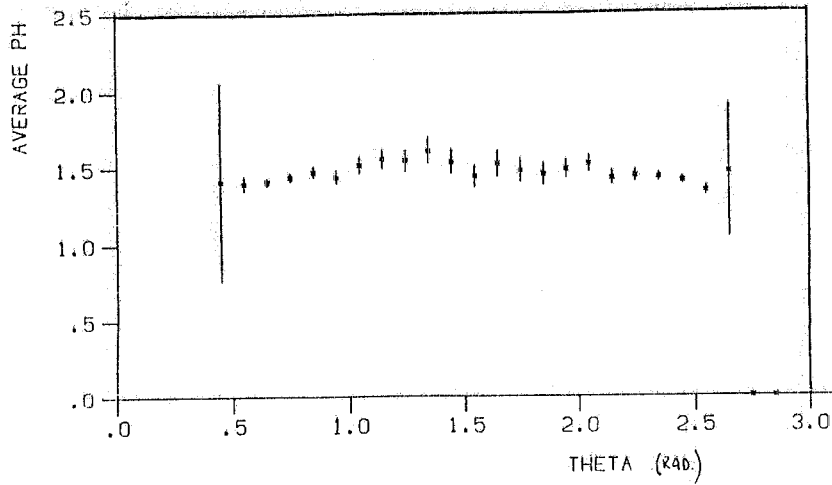

FIG. 4 - Average pulse height vs. $\sin \theta$.

The distribution for Bhabhas, cosmes and mu pairs are shown in Fig. 5. The actual mean values and σ 's (in arbitrary units) are tabulated in the Table I.

TABLE I

	Cosmics	μ	Bhabhas.
$\langle P.h. \rangle_{\text{truncated}}$	0.65	0.85	0.99
	0.19	0.21	0.21

The ratio between them is in good agreement with theoretical prediction⁽³⁾. Part of the difference in resolution can be explained naively if one expects the resolution to depend in a Poisson fashion on the number of individual ionization clusters so if we have 1.6 more "losses" for Bhabhas than for minimum ionizing we expect a factor $\sqrt{1.6} = 1.26$ which is close to what we actually see. We see that the resolution scales with the square root of the number of samples as expected (see Fig. 6).

The resolution of our device has two components: one is the intrinsic resolution which depends on the gas, density, pressure, sample thickness; the other is the possible systematics: different behaviour of some channel, noise and so on. To observe the effect of the intrinsic resolution we split 10 hits tracks into 2 segments, say Front and Rear respectively, and compute separately the mean pulse height, X . In Fig. 7 is shown the distribution of the quantity

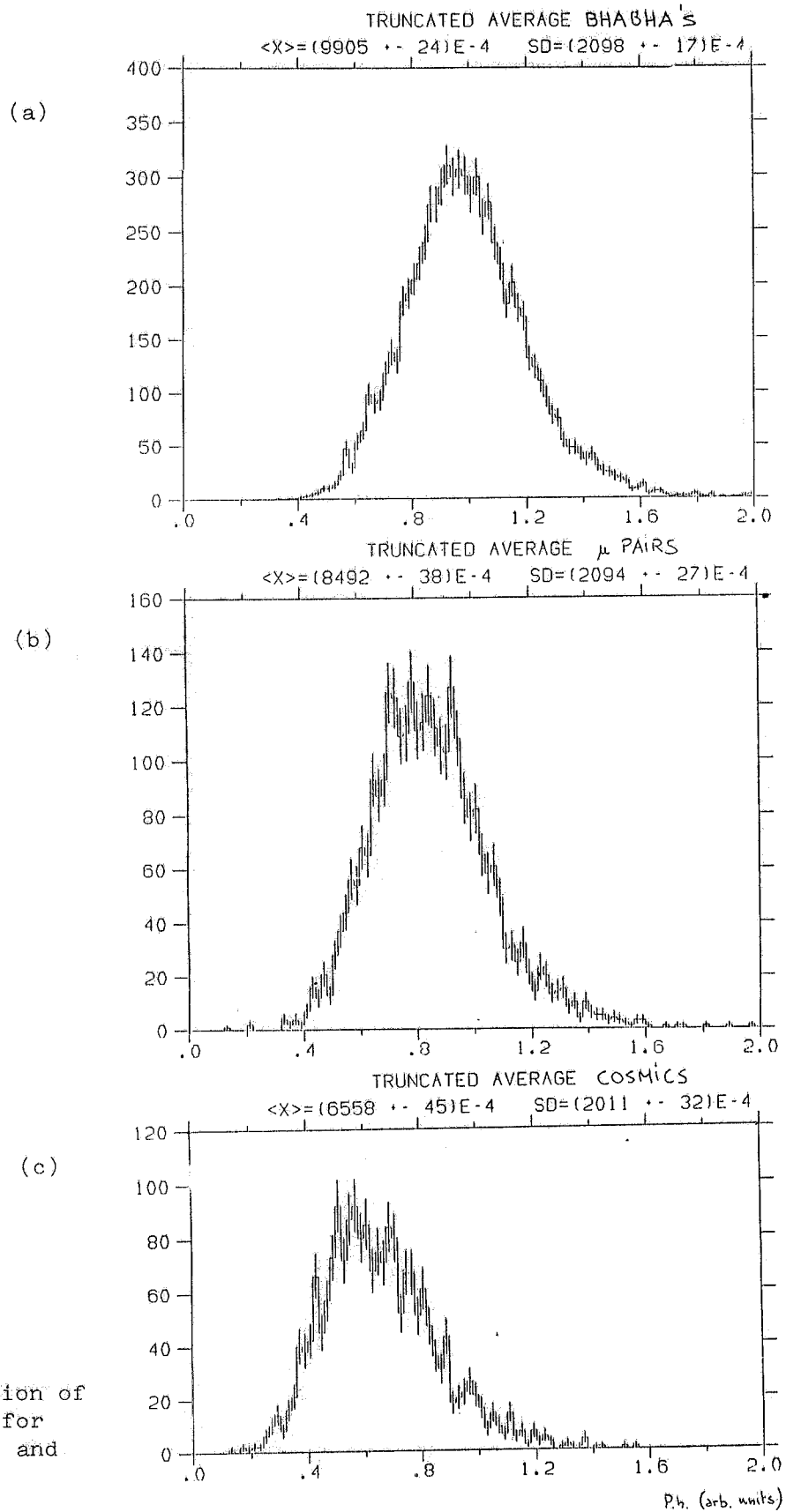

FIG. 5 - Distribution of truncated average for Bhabhas (a), μ (b), and cosmic (c).

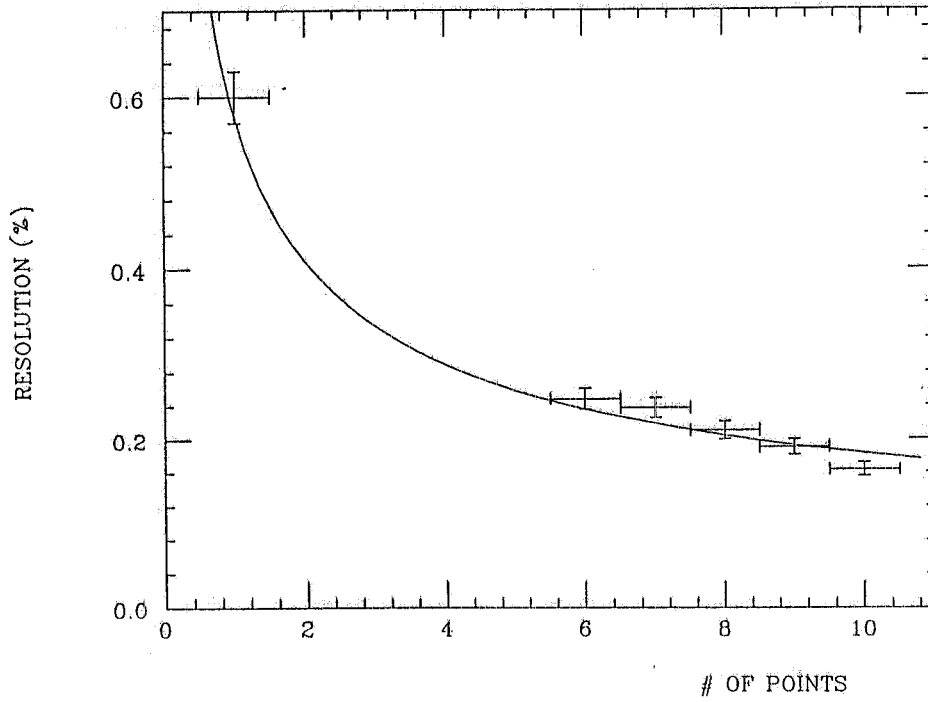

FIG. 6 - Resolution (σ/peak) vs. number of samplings.

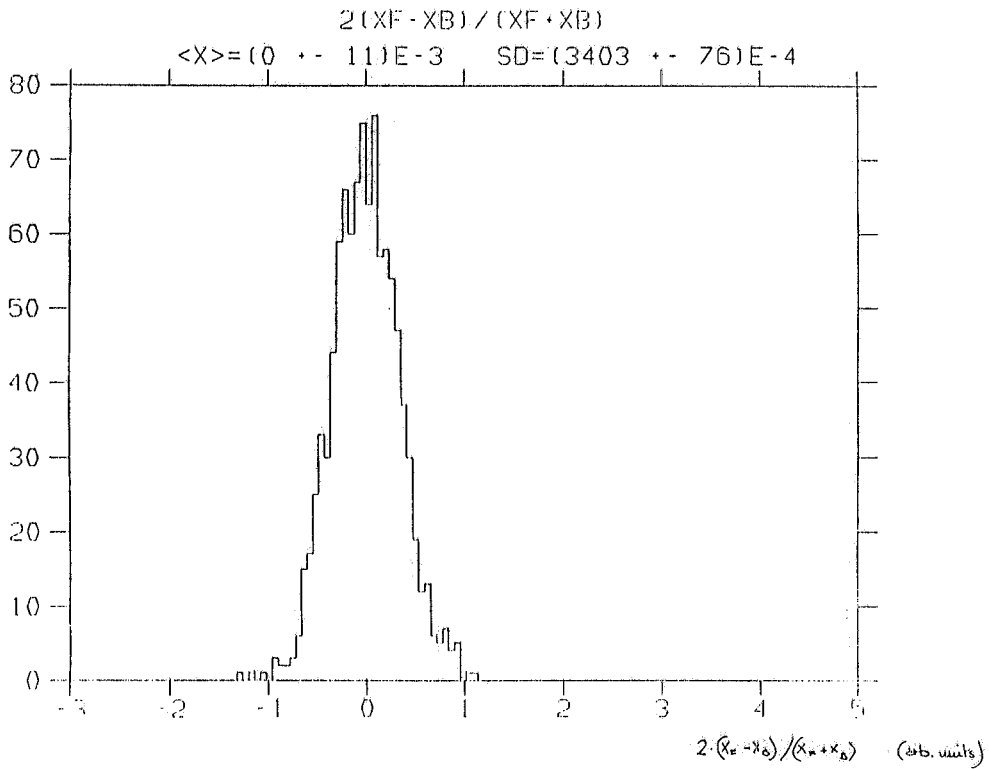

FIG. 7 - Intrinsic resolution plot.

$$2(X_F - X_R)/(X_F + X_R)$$

whose r.m.s. is equal to two times the intrinsic resolution for 10 hit tracks (σ_{10}) and the factor 2 is equal to ($\sqrt{2}$ for the half number of samples) $\cdot (\sqrt{2}$ since we are comparing two independently varying variables). So we have:

$$\sigma_{10}^2 = \sigma_{\text{intrinsic}}^2 + \sigma_{\text{systematic}}^2$$

σ_{10} varies between 17% and 18% depending on the period, $\sigma_{\text{intrinsic}} = 17\%$, so we are left with a systematic effect of at most 6% to be added in quadrature. The fact that the mean value is 0 assures us that there are no systematic variation, in the evaluated dE/dx , along the track.

3.- APPLICATION

One of good features of the structure of the cell is the differential readout: any 0-charge integral pulse, like cross-talk induced pulses, is cancelled out. Moreover one can use this fact to detect hit caused by a cross talk induced pulse which had one edge above threshold (see Fig.8).

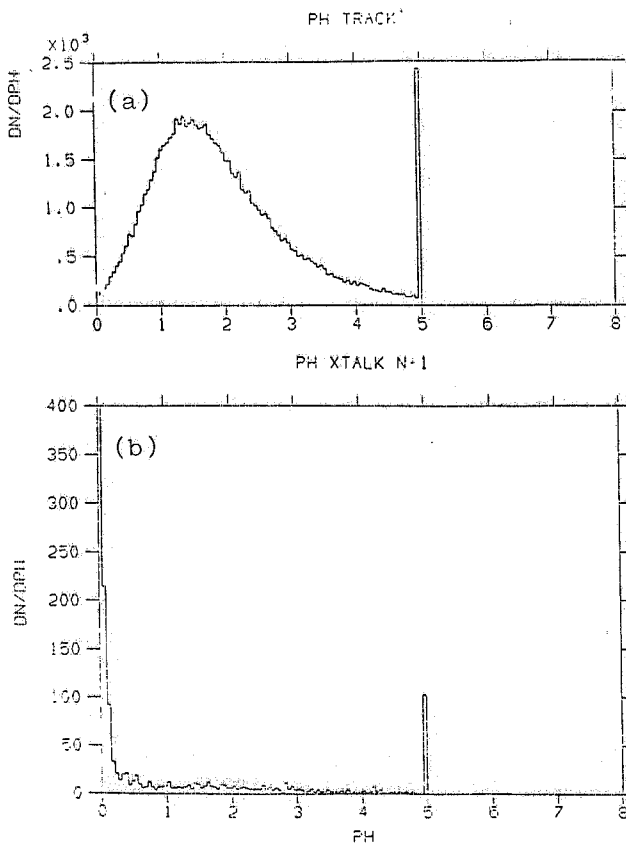

Incidentally we notice that the wire differential readout has another good characteristic as far as δ rays are concerned. These low energy electrons tend to spiral around the sense wire under the influence of the magnetic field and so most of the ionization they cause is cancelled out.

The extent to which our dE/dx setup can be used for particle identification is

FIG. 8 - Ph spectrum for real particles (a), and for cross-talk induced hits (b).

limited by the relatively poor resolution. In a limited momentum range, i. e. below the minimum ionization point of protons, the dE/dx can be used to separate (statistically) protons from kaons (see Fig. 9).

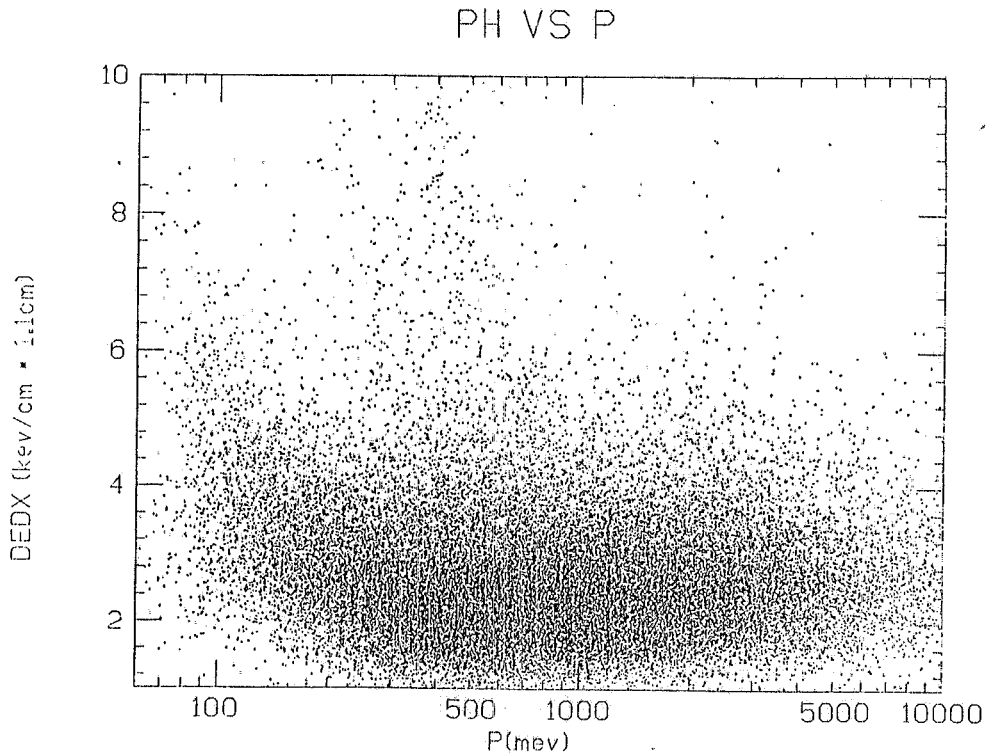

FIG. 9 - dE/dx vs. momentum for multihadron events.

The main application, however, will be its use in conjunction with calorimetry to separate electrons from pions to tag heavy flavor semileptonic decay. In Fig. 10 is shown, for example, the dE/dx distribution for the

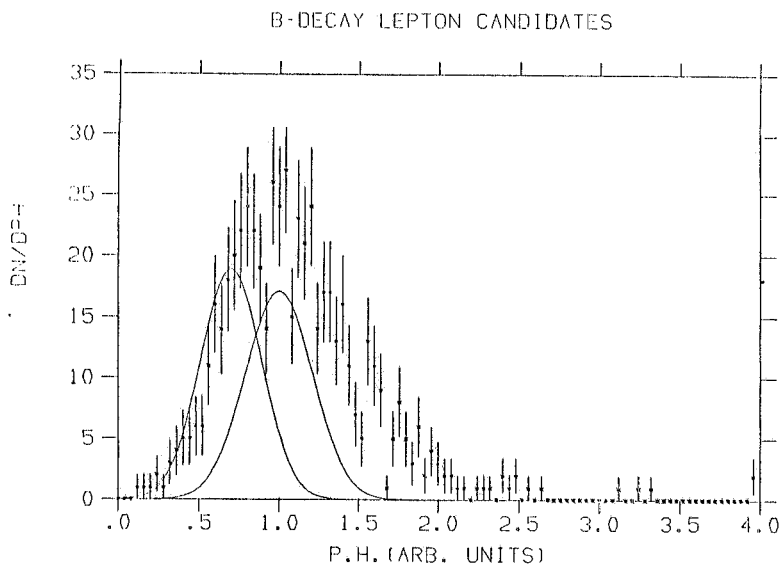

FIG. 10 - dE/dx for the B-decay electron candidates.

candidate electrons from B decay as determined by calorimetry before any transverse momentum cut (the only cut apart from those regarding the longitudinal shower development is on the momentum which is required to be greater than 2 GeV)⁽⁴⁾. Montecarlo studies expect around 50% pion background: with dE/dx we can clearly eliminate part of this background, by cutting away the low ionization peak visible in Fig. 10. Another background which is the explanation of the tail at high dE/dx is due to misidentification of double tracks in the central drift (for example γ conversion in the beam pipe). This type of background is being studied by means of the dE/dx information.

ACKNOWLEDGEMENTS

I wish to thank in particular U.Denni whose contribution was essential while building and mounting the electronic set-up. I had many fruitful and helpful discussions with M.Piccolo, H.Band and I was helped a lot by many members of the MAC collaboration.

REFERENCES AND NOTES

- (1) W.T.Ford et al., in Proceedings of the Intern. Conf. on Instrumentation for Colliding Beam Physics, Ed. by W.W.Ash, Report SLAC-PUB-2894.
- (2) Monochromatic from dE/dx point of view is roughly defined, since we are interested in particles having approximately the same energy loss.
- (3) For a recent compilation of tables of constants see R.M.Sternheimer et al., Density effect for the ionization loss of charged particles in various substances, Atomic and Nuclear Data Table (1984), also preprint BNL-33571; For a recent review of the energy loss subject see A.H.Walenta, Review of the Physics and Technology of Charged Particle Detectors, Proceedings of the 11th SLAC Summer Institute on Particle Physics, 1983 (SLAC rep. no. 267).
- (4) E.Fernandez et al., Lifetime of particles containing b quark, Phys. Rev. Letters 51, 1022 (1983).