

To be submitted to  
Nuclear Instr. and Meth.

ISTITUTO NAZIONALE DI FISICA NUCLEARE  
Laboratori Nazionali di Frascati

LNF-79/52(P)  
20 Agosto 1979

P. Spillantini: EFFICIENCY OF A SENSE WIRE IN THE  
REGION OF ITS SUPPORTING HOOK IN A DRIFT CHAMBER.

LNF - 79/52(P)  
20 Agosto 1979

P.Spillantini: EFFICIENCY OF A SENSE WIRE IN THE REGION OF ITS SUPPORTING HOOK IN A DRIFT CHAMBER.

Usually wire chambers for devices covering a large solid angle around the interaction region of a storage ring are installed with their anode wires stretched parallel to the beam axis<sup>(1)</sup>.

However structures based only on longitudinal wires are sometimes not sufficient, either for central devices covering much down in zenith, or for devices used in conjunction with a central toroidal coil, where the longitudinal coordinate must be accurately measured. Recourse has indeed been made to rectangular chambers with anode wires stretched between opposite rods of one frame and arranged in a suitable geometry to cover the desired solid angle<sup>(2)(3)</sup>; but assembly mechanics is not trivial<sup>(3)</sup>, compactness and lightness are difficult to obtain for the large number of frames introduced in the detector, and problems can also arise with regard to data analysis.

For a number of experimental situations the straightforward solution would be to build a structure with "poligonal wires", i.e. with each wire supported at evenly spaced points, to form a polygonal figure approximating a "circle" perpendicular to the beam axis and centered on it. The more the supports, the better the polygon approximates to a circle, but an inefficiency proportional to the number of supports is inevitably introduced.

For this reason the mechanical hook which supports the wire plays an important role in the functioning of the device.

In this short note a preliminary measurement of the inefficiency introduced by a metallic "nail-head" hook (see Fig.1) printed on a fiberglass support<sup>(4)</sup> is reported.

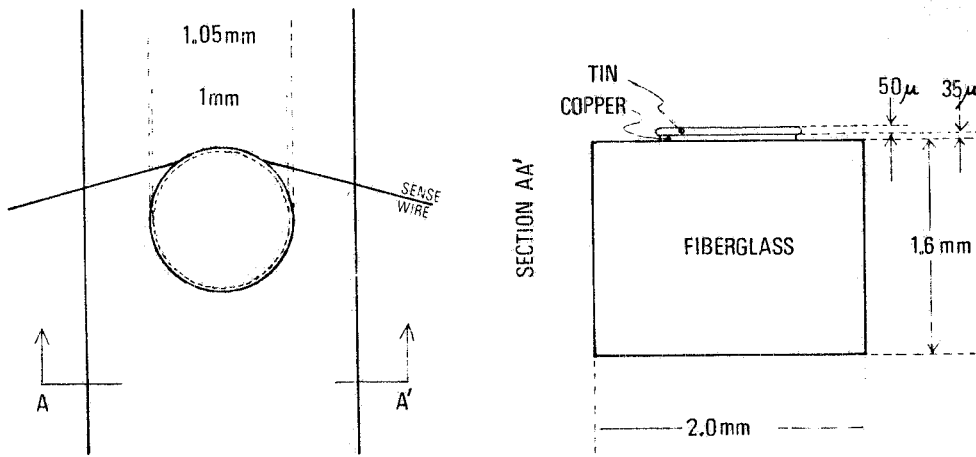

FIG. 1

For the test a sector of a "polygonal wire" chamber was constructed, where the sense wires were bent through  $30^\circ$  at the "nail-head" support (see Fig. 2a). Ten anode wires were positioned at the end of a drift space 2 cm long, and behind them the chamber was terminated by a corrugated aluminium plate to simulate the effect of an adjacent specular drift space (see Fig. 2b).

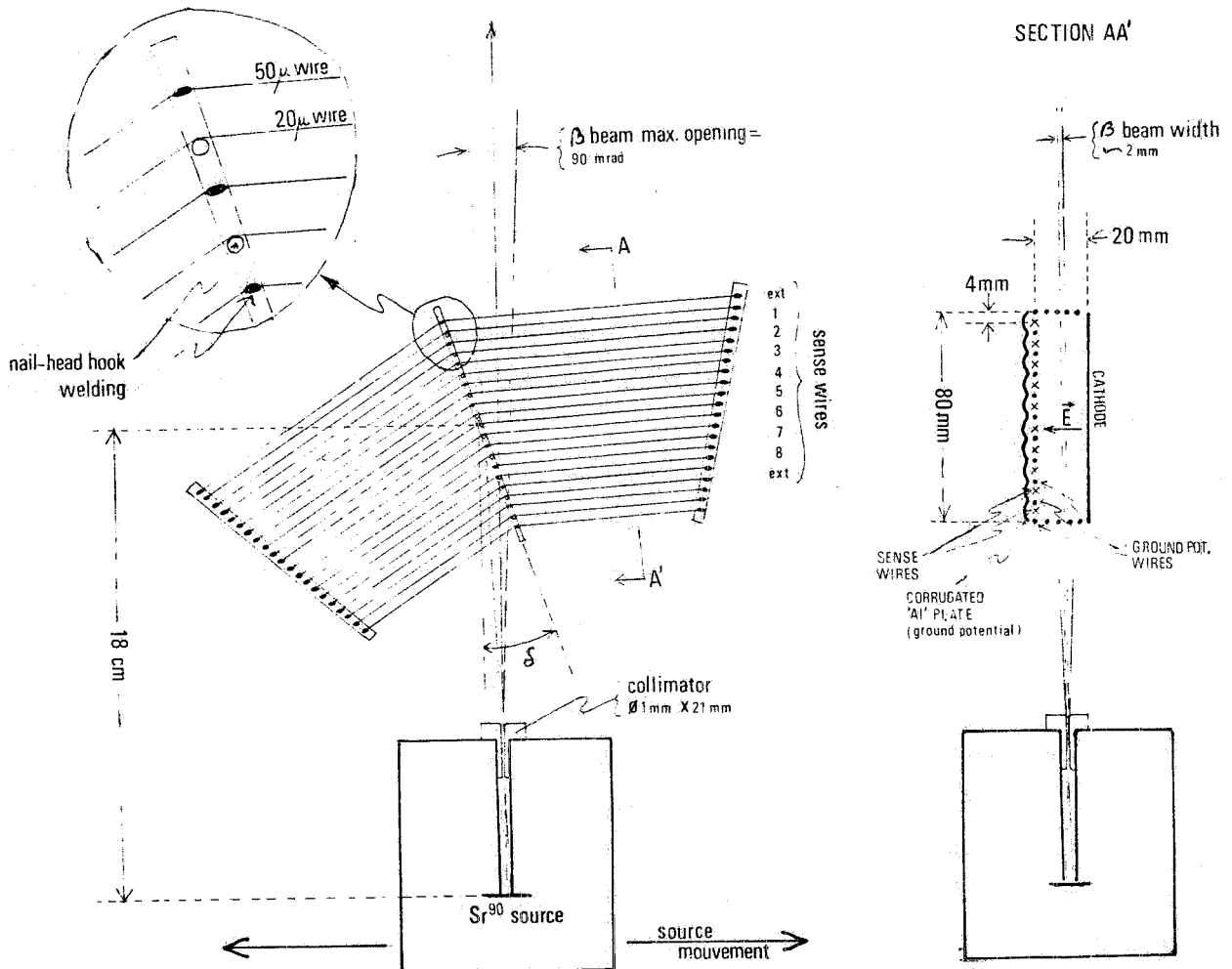

FIG. 2

The test was performed using a collimated electron beam from a radioactive source ( $\text{Sr}^{90}$ , 10 mCu in intensity) to cross the drift space on a "equipotential plane" (see Fig.2b). The chamber could rotate around an axis perpendicular to the equipotential plane (see Fig.2a) and the source could be moved by means of a micrometric screw in this plane and normally to the electron beam direction.

The radioactive source could not be brought closer to less than 18 cm from the rotation axis of the chamber, preventing the use of thin scintillation counters to trigger the chamber read-out. For this reason the efficiency of one central wire of the chamber (namely the wire n°5) was observed using the trigger coincidence of other four wires around it (namely wires n°1,3,7,8). The electronic scheme is reported in Fig.3.

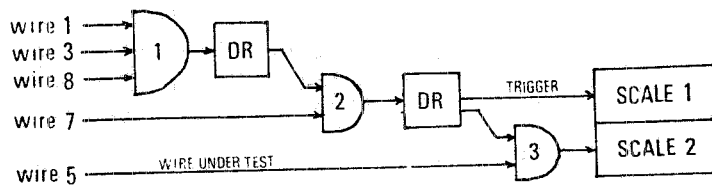

FIG. 3

As only one positive power supply was available, only the global H.V. plateau of the 4-fold trigger coincidence could be controlled, registering its rate in fixed time intervals (see Fig.4). The threshold for the output pulse from the chamber was set at 2 mV on a  $50\Omega$  impedance for all the wires, and the cathodic H.V. to -2.5 kV.

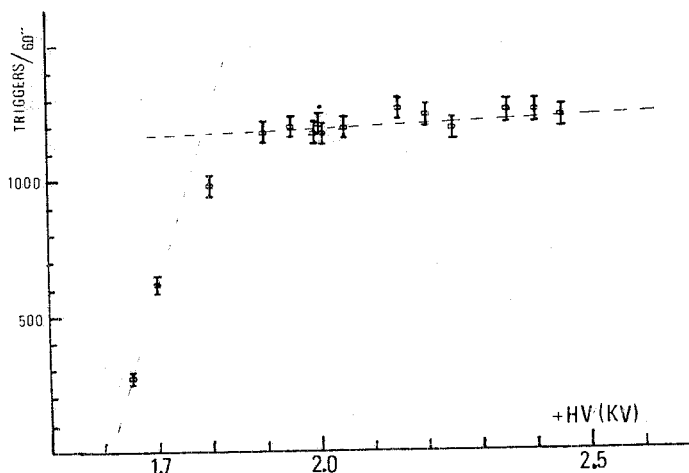

FIG. 4

The efficiency was measured for various anodic H.V., doing the electron beam to scan the tested sense wire around its support, at a constant angle  $\delta = 20^\circ$  (see Fig.5).

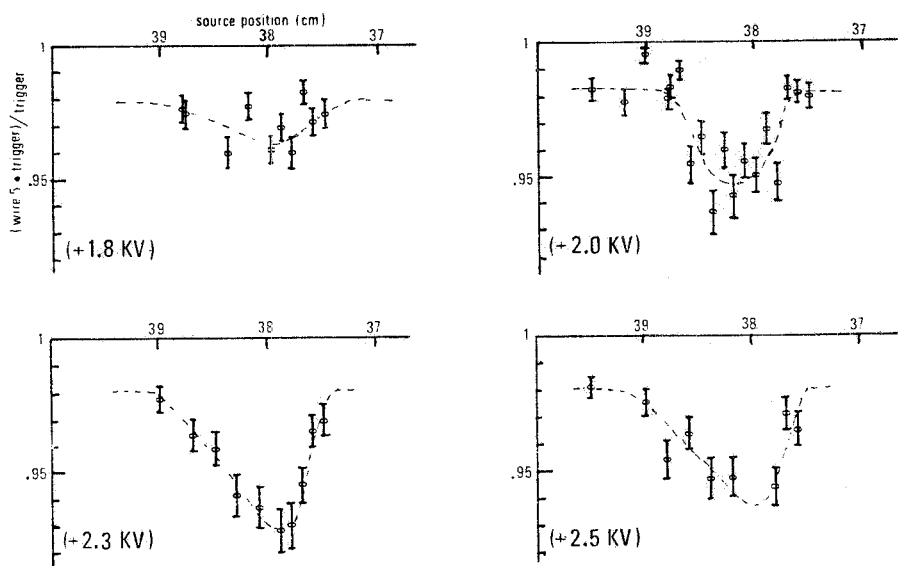

FIG. 5

The radioactive source was collimated by a 1 mm diameter collimator, 21 mm long. In fact the cross-section of the electron beam at the level of the n°5 wire was of nearly rectangular shape, 2 mm x 12 mm, the smaller dimension being defined by the electronic resolution, and its distribution was more crowded near the center of the broad side.

This beam cross-section accounts for the  $\sim 8$  mm width (fwhm) of the efficiency hole found in the efficiency trends of Fig.5. The two trends at 1.8 kV and 2.0 kV are probably affected either by an enlargement of the inefficient portion of the wires n°3 and n°7 around their supporting hooks, or by inefficient saturation of the drift velocity.

Instead for the two highest anodic H.V. values the area of the inefficiency hole can be easily evaluated<sup>(5)</sup>; subtracting from it the area corresponding to the inefficiency of the 5-fold coincidence of the n°5 wire with the trigger 4-fold coincidence (measured separately far away from the scanned "nailhead" support, and amounting to  $(2 \pm 0.5)\%$ ) the following two values are obtained:

$$0.41 \pm 0.07 \text{ mm at } 2.3 \text{ kV,}$$

$$0.32 \pm 0.08 \text{ mm at } 2.5 \text{ kV.}$$

These values are unexpectedly small and correspond roughly to a full efficiency of the sense wire outside the portion hidden by the top of the "nail-head" support (see Fig.6).

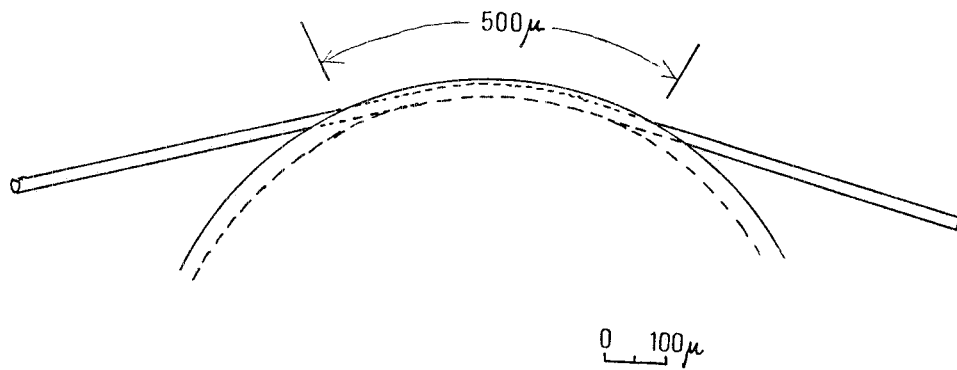

FIG. 6

The author wishes to thank Mr. R. Di Stefano for the realization of the metallic "nail-head" hooks and Mr. M. Giardoni for its help during the test.

#### REFERENCES AND NOTES

- (1) - See for example the sc solenoid at the ISR, the CELLO, TASSO and JADE devices at PETRA, and MARK II at SPEAR.
- (2) - See for example the SFM at the ISR.
- (3) - A Bechini et al., A modular drift-chamber vertex detector at the CERN-ISR, Nucl. Instr. and Meth., 156, 181 (1978).
- (4) - The "nail-head" shape was obtained by depositing a layer of tin on the fiberglass (already exposed) before taking away the photoresistor.