

Laboratori Nazionali di Frascati

LNF-72/34

C. Bacci, G. Penso, G. Salvini, B. Stella, R. Baldini-Celio, G. Capon,
C. Mencuccini, G. P. Murtas, A. Reale and M. Spinetti: MULTIHA-
DRONIC CROSS SECTIONS FROM e^+e^- ANNIHILATION AT C. M.
ENERGIES BETWEEN 1.4 AND 2.4 GeV.

Estratto da: Phys. Letters 38B, 551 (1972)

MULTIHADRONIC CROSS SECTIONS FROM e^+e^- ANNIHILATION
AT C. M. ENERGIES BETWEEN 1.4 AND 2.4 GeV

C. BACCI, G. PENSO, G. SALVINI and B. STELLA

Istituto di Fisica dell'Università di Roma, Italy
Istituto Nazionale di Fisica Nucleare, Sezione di Roma, Italy

R. BALDINI-CELIO, G. CAPON, C. MENCUCCINI, G. P. MURTAS,
A. REALE and M. SPINETTI

Laboratori Nazionali del CNEN, Frascati, Italy

Received 16 February 1972

Multihadronic production has been observed at the Adone e^+e^- storage ring, in the c.m. energy range 1.4 - 2.4 GeV. The cross sections for the reactions $e^+ + e^- \rightarrow 2\pi^\pm + n\pi^0$ ($1 \leq n \leq 4$) and $e^+ + e^- \rightarrow (4\pi^\pm + n\pi^0; 6\pi^\pm)$ ($0 \leq n \leq 2$) have been measured, assuming that the produced particles are only pions with a pure phase space momentum distribution.

In an experiment performed at the Adone electron-positron storage ring we have studied the reactions:

$$e^+ + e^- \rightarrow \text{multihadronic production} \quad (1)$$

at center of mass energies $2E$ between 2×0.7 and 2×1.2 GeV.

We summarize our results as follows: Multiple hadronic events are produced at our energies. These events have three or more hadrons in the final state, and neutral pions are present in a large percentage of the cases. The cross sections for these processes are relatively large, and are in the region of values covered by the "pointlike" cross section for muon pair production (fig. 2). Reaction $e^+ + e^- \rightarrow \pi^+ + \pi^- + \pi^0$ has a cross section of the order of 2×10^{-33} cm² at c.m. energies averaged over 1.85 - 2.1 GeV.

In what follows we give the experimental details, and consider possible theoretical interpretations.

Our experimental apparatus (fig. 1) is similar to the one described in a previous paper [1]. It mainly consists of four blocks (A, B, D, S) of scintillation counters, lead converters and spark chambers, above and below the target area, and covers about $0.25 \times 4\pi$ solid angle. It may detect charged particles with efficiency, close to one and γ -rays with an energy dependent efficiency which is typically 80% for an energy $E_\gamma \geq 250$ MeV [2]. A pion (kaon) must have at

least 95 MeV (145 MeV) kinetic energy in order to trigger the electronics, and at least 55 MeV (95 MeV) to give a recognizable track in the spark chambers.

During the experiment we have placed close to the doughnut two cylindrical spark chambers. These are very thin (~ 0.6 g/cm²) and are convenient to improve the localization of the e^+e^- annihilation point and the identification of the charge of the particles. The apparatus was triggered whenever at least three tracks or showers had been detected in three of the four blocks ABDS, and counter α or β gave a signal (fig. 1); i.e. one of the particles had to be charged.

Using this trigger we have obtained 146 multiple events; they have been distributed in categories c (see table 1) according to the number of showers and tracks observed and to the c.m. energy. The luminosity has been measured by using as a monitor the scattering $e^+ + e^- \rightarrow e^+ + e^-$ at small momentum transfer [3]. The values of the luminosity are consistent with our contemporary results on the less frequent reaction $e^+ + e^- \rightarrow \gamma + \gamma$ [1].

We assume in the following that the multiple events we discuss here are of hadronic nature, with the particles directly produced being pions or kaons. In fact, the number of nuclear interactions of the charged particles in the absorbers is in agreement with what may be expected if the charged particles are pions.

The relative abundance of multiple hadronic

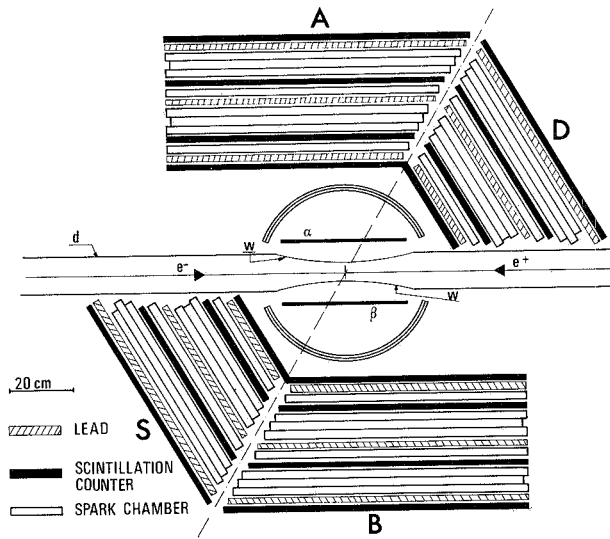

Fig. 1. Experimental apparatus: front view from Adone center. d: doughnut; w: 0.15 mm stainless steel window.

events at our energies makes improbable any origin different from the well known [4] one photon annihilation diagram. The number of events from virtual γ - γ interaction [5] (that is reaction $e^+ + e^- \rightarrow e^+ + e^- + \text{hadrons}$) having the necessary configuration to be observed in our spark chambers, should be definitely lower than our results. More specifically, we assume also that the more relevant processes which contribute to our events are the following:

$$\begin{aligned}
 e^+ + e^- &\rightarrow \pi^+ + \pi^- + n\pi^0, & \text{with } 1 \leq n \leq 4, & (2) \\
 e^+ + e^- &\rightarrow \pi^+ + \pi^- + \pi^+ + \pi^- + n\pi^0, & \text{with } 0 \leq n \leq 2, & (3a) \\
 e^+ + e^- &\rightarrow 3\pi^+ + 3\pi^-. & & (3b)
 \end{aligned}$$

This correspond to the assumption that disregarding processes with more than six pions or with kaons does not affect appreciably our final results on the total cross section.

The cross sections at a given energy for the different processes (2), (3) may be in principle obtained by a system of relations of the type

$$N_c = L_t \sum_i \sigma_i \epsilon_{ic}, \quad (4)$$

where N_c is the total number of the events belonging to the category of table 1. By L_t we indicate the total luminosity for each energy. The eight cross sections σ_i are those related to the processes listed in eqs. (2) and (3). ϵ_{ic} is the detection efficiency for events of category c coming from reaction i. The efficiencies we

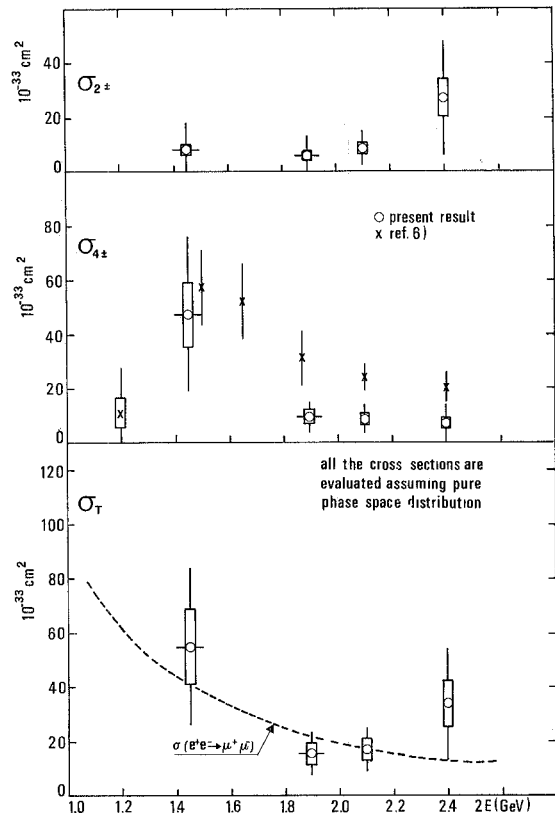

Fig. 2. Results on σ_T (total cross section for reactions (1)), $\sigma_{4\pm}$ (reactions (3)), $\sigma_{2\pm}$ (reactions (2)) as a function of $2E$, total energy in c.m. system. The rectangles indicate a reasonable estimate of the width of our possible systematic errors. The bars represent the statistical errors. All these values are obtained under the assumption of a pure invariant phase space distribution: the limitations of this model are discussed in the text. The dashed line indicate the total cross section for the process $e^+ + e^- \rightarrow \mu^+ + \mu^-$.

have used have been evaluated under the hypothesis of pure invariant phase space momentum distribution. The evaluation has been made by the Monte Carlo method taking into account the details of our experimental apparatus, the length of the interaction region, the probabilities for detection of the γ -rays and for nuclear interaction of the charged particles.

We have looked for the best solution to the relations (4) under the condition that all the σ_i should be positive or zero. Because of the poor statistics each cross section thus estimated has a very large error; however it is possible to give a more reliable value for the sum of the cross sections:

Table 1
Distribution of our events according to the number
of tracks and showers at various energies

Cate- gory c	Num- ber of tracks	Num- ber of showers	c.m. energy $2E$ (GeV)						
			1.4	1.5	1.85	1.9	1.94	2.1	2.4
1	1	2	1	2	4	4	0	21	8
2	1	3	0	1	0	0	0	0	1
3	2	1	1	2	1	4	5	19	7
4	2	2	1	0	1	1	2	8	3
5	2	3	0	0	1	0	1	4	0
6	3	0	2	5	1	4	3	9	2
7	3	1	1	0	0	2	0	5	0
8	3	2	0	0	0	0	0	3	1
9	4	0	1	0	0	0	0	4	0
Luminosity ($L_t \times 10^{-34}$) cm^{-2}			0.76	2.96	2.28	6.2	4.1	24.8	4.6

$\sigma_{2\pm}$ = sum of the cross sections for processes (2),

$\sigma_{4\pm}$ = sum of the cross sections for processes (3),

$\sigma_T = \sigma_{2\pm} + \sigma_{4\pm}$ = total cross section for processes (1).

This division is convenient, due to the fact that the events with at least 3 charged tracks detected (categories 6, 7, 8, 9 of table 1) contribute only to $\sigma_{4\pm}$.

These cross sections are reported in table 2 and shown in fig. 2 and refer to four different c.m. energy regions $2E$: 1.4 - 1.5 GeV; 1.85 - 1.94 GeV; 2.1 GeV; 2.4 GeV.

The cross sections are given with two kind of errors indicated. The lines (fig. 2) are pure statistical errors. The rectangle indicate a reasonable estimate of the width of our possible systematic errors, as due to various sources: uncertainties on the evaluation of the nuclear interactions of the charged particles, and on the detection efficiency of the low energy photons; distinction between low energy γ -rays and tracks; actual sensitive area of the apparatus; uncertainties in the elaboration of relations (4); possible radiative corrections to the monitor, not yet calculated.

The data in table 1 indicate the presence of a significant number of e.m. showers (191 showers and 298 tracks). Actually our best fits give the general indication that multiple reactions with neutral pions are relatively more abundant than those with only charged particles. As an average we have

$$\frac{\sigma(4 \text{ or } 6 \text{ charged pions} + \text{neutral pions})}{\sigma(4 \text{ or } 6 \text{ charged pions})} \approx 2.$$

In fig. 2 we report also the data from ref. [6]. The energy behaviour of our $\sigma_{4\pm}$ data is in reasonable agreement with that of ref. [6] and seems to reflect the behaviour of the $\pi^+ + \pi^- + \pi^+ + \pi^-$ channel reported by the same authors. According to Bramon and Greco [8] this effect could be due to the ρ' production.

In this case the same authors predict a branching ratio $(\rho' \rightarrow \pi^+ + \pi^- + \pi^+ + \pi^-)/(\rho' \rightarrow \pi^+ + \pi^- + \pi^0 + \pi^0)$ of the order of unity. However this does not seem to agree with our results on $\sigma_{2\pm}$, which indicate that the cross section for the process $e^+ + e^- \rightarrow \pi^+ + \pi^- + \pi^0 + \pi^0$ in the ρ' region is lower than the corresponding cross section for the process $e^+ + e^- \rightarrow \pi^+ + \pi^- + \pi^+ + \pi^-$ reported in refs. [6, 7].

We note that refs. [6, 7] quote some higher values for $\sigma_{4\pm}$ and σ_T in the energy region around 2 GeV. This difference can perhaps be explained considering the different kinematical regions explored and the different cuts in energy, due to the different triggers. In fact the assumption of a pure invariant phase space distribution of the pions, used both by us and by the authors of refs. [6, 7] is only a rough approach.

We have actually observed discrepancies between our experimental data and the predictions of the phase space model. For instance in the cases when the reaction $e^+ + e^- \rightarrow \pi^+ + \pi^- + \pi^0$ is excluded by momentum conservation, events with two tracks and one shower detected (category 3) seem to be more coplanar than expected.

We are now trying alternatively, to interpret our results by assuming that processes (1) go through some particular channel, like for instance, $e^+ + e^- \rightarrow \omega + \pi^0$; $\pi^+ + \pi^- + \eta$. For instance at $2E = 2.4$ GeV the multiplicity of our events (see table 1) can be well explained with only the single process $e^+ + e^- \rightarrow \pi^+ + \pi^- + \eta$, when assuming for η the known decays and their branching ratios [9] and disregarding the dynamical correlations. In this case the value of σ_T for $e^+ + e^- \rightarrow \pi^+ + \pi^- + \eta$ turns out to be $(40 \pm 10) \times 10^{-33} \text{ cm}^2$.

Furthermore we have also investigated, in the energy range $1.85 \leq 2E \leq 2.1$ GeV, by means of a detailed kinematical analysis, the events of categories 3 and 4 of table 1 in order to separate the processes:

$$e^+ + e^- \rightarrow \pi^+ + \pi^- + \pi^0, \quad (5)$$

$$e^+ + e^- \rightarrow K^+ + K^- + \pi^0. \quad (6)$$

In category 3 we find that only 10 events, out of a total of 29, could be due to reaction (5); from this we obtain

Table 2

Cross sections for the processes $e^+ + e^- \rightarrow$ multiple production, as obtained under the following hypothesis (see text):

- a) Multiple production follows a pure phase-space distribution.
- b) Charged particles observed are pions.
- c) The photons come from neutral pions.

The first error is the statistical one. In parenthesis we report a reasonable estimate of the systematic error.

Type of process	Cross section at different total c.m. energies $2E$			
	(10^{-33} cm^2)			
	$2 \times (0.7-0.75)$ (GeV)	$2 \times (0.925-0.97)$ (GeV)	$2 \times (1.05)$ (GeV)	$2 \times (1.2)$ (GeV)
$e^+ + e^- \rightarrow 2$ charged pions + neutrals (reaction (2))	$8 \pm 8 (\pm 2)$	$6 \pm 5 (\pm 2)$	$8.5 \pm 4 (\pm 2)$	$27 \pm 14 (\pm 7)$
$e^+ + e^- \rightarrow$ at least four charged pions + any number of neutrals (reaction (3))	$47 \pm 16 (\pm 12)$	$9.5 \pm 3 (\pm 2)$	$8.5 \pm 3 (\pm 2)$	$7 \pm 5 (\pm 2)$
$e^+ + e^- \rightarrow$ any multiple process with at least 3 particles, two at least being charged (reactions (2)+(3))	$55 \pm 15 (\pm 14)$	$15.5 \pm 4 (\pm 4)$	$17 \pm 4 (\pm 4)$	$34 \pm 12 (\pm 9)$

$$\sigma(e^+ + e^- \rightarrow \pi^+ + \pi^- + \pi^0) \leq (5 \pm 2) \times 10^{-33} \text{ cm}^2.$$

In category 4 there is only one event which can be interpreted as due to process $e^+ + e^- \rightarrow \pi^+ + \pi^- + \pi^0$. This corresponds to a cross section of $(2 \pm 2) \times 10^{-33} \text{ cm}^2$, in agreement with the previous value.

From a similar analysis in the same energy region, one gets a limiting value: $\sigma(e^+ e^- \rightarrow K^+ + K^- + \pi^0) \leq 6 \times 10^{-33} \text{ cm}^2$ with 90% confidence level.

A comparison of our results with the theoretical predictions is not easy, for there is not a unique theory of reactions (1) at our energies. The theoretical models presented until now may be divided into two types: a first group is based on vector dominance, either with the well known (ρ, ω, ϕ) vector mesons, which are supposed to be present at high energies with the slowly decreasing tail of their propagator [10], or with a new meson (the ρ') [11]. These models do not exclude cross section values in the range of $(10 - 30) \times 10^{-33} \text{ cm}^2$ at our energies, which could agree with our results.

The second group of models, like the jet model [12] and the statistical model [13], is connected with the general problem of deep inelastic electron scattering. These models predict a value $\sigma(e^+ + e^- \rightarrow \text{hadrons}) \approx \sigma(e^+ + e^- \rightarrow \mu^+ + \mu^-)$. In the simplest quark model case [14] we should have $\sigma(e^+ + e^- \rightarrow \text{hadrons}) \approx \frac{2}{3} \sigma(e^+ + e^- \rightarrow \mu^+ + \mu^-)$. In fig. 2 we have reported the total cross section for the process $e^+ + e^- \rightarrow \mu^+ + \mu^-$.

It is quite possible, of course, that the contributions from more than one model, which are not alternative choices, must be added together, also taking into account their interferences.

Work is in progress to increase the statistics and to make a more detailed kinematical analysis of our events. A new experimental apparatus

specifically designed to observe these new hadronic processes is under construction.

We wish to thank our technicians. V. Bidoli, for his continuous assistance during the experiment and Mr. Di Stefano and coworkers for their helpful assistance. We thank also the Adone staff for the smooth operation of the machine.

References

- [1] C. Bacci et al., *Lett. al Nuovo Cim.* 2 (1971) 73.
- [2] G. Capon, M. A. Locci, G. P. Murias and G. Penso, *Frascati Int. Rep. LNF 70/13* (1970).
- [3] G. Barbiellini, B. Borgia, M. Conversi and R. Santonico, *Atti dell'Acc. Naz. dei Lincei* 44 (1968) 233.
- [4] R. Gatto, *Proc. Int. Symp. on Electron and photon interaction, Hamburg, vol. 1* (1965) p. 106; N. Cabibbo and R. Gatto, *Nuovo Cim.* 20 (1961) 184.
- [5] N. Arteaga-Romero, A. Jaccarini, P. Kessler and J. Parisi, *Lett. al Nuovo Cim.* 4 (1970) 933; 1 (1971) 935; S. J. Brodsky, T. Kinoshita and H. Terazawa, *Phys. Rev. Letters* 25 (1970) 972.
- [6] G. Barbarino et al., *Frascati Int. Report. LNF 71/96* (1971); M. Grilli, *Frascati Int. Rep. LNF 71/100* (1971).
- [7] B. Bartoli, F. Felicetti, H. Ogren, V. Silvestrini, G. Marini, A. Nigro, M. Spinelli and F. Vanoli, *Frascati Int. Rep. LNF 71/91* (1971); *Phys. Letters* 36B (1971) 598.
- [8] A. Bramon and M. Greco, *Frascati Int. Rep. LNF 71/97* (1971).
- [9] Particle Data Group, *Rev. Mod. Phys.* 43 (1971) S1.
- [10] J. Layssac and F. M. Renard, *Lett. al Nuovo Cim.* 1 (1971) 197.
- [11] A. Bramon and M. Greco, *Lett. al Nuovo Cim.* 1 (1971) 739.
- [12] N. Cabibbo, G. Parisi and M. Testa, *Lett. al Nuovo Cim.* 4 (1970) 35.
- [13] S. Ferrara, M. Greco and A. F. Grillo, *Lett. al Nuovo Cim.* 4 (1970) 1.
- [14] J. D. Bjorken, *Phys. Rev.* 148 (1966) 1467; S. D. Drell, *Rapporteur's Report, The Amsterdam Intern. Conf. on Elementary Particles* (1971); R. Jackiw and G. Preparata, *Phys. Rev. Letters* 22 (1969) 975.

* * * * *