

Laboratori Nazionali di Frascati

LNF-70/61

B. Bartoli, B. Coluzzi, F. Felicetti, V. Silvestrini, G. Goggi,
D. Scannicchio, G. Marini, F. Massa and F. Vanoli :
MULTIPLE PARTICLE PRODUCTION FROM e^+e^- INTERAC-
TIONS AT C. M. ENERGIES BETWEEN 1.6 AND 2 GeV

Estratto da : Nuovo Cimento 70A, 615 (1970)

B. BARTOLI, *et al.*
21 Dicembre 1970
Il Nuovo Cimento
Serie X, Vol. 70 A, pag. 615-631

Multiple Particle Production from e^+e^- Interactions at C.M. Energies between 1.6 and 2 GeV.

B. BARTOLI, B. COLUZZI, F. FELICETTI and V. SILVESTRINI

Laboratori Nazionali del Comitato Nazionale per l'Energia Nucleare - Frascati (Roma)

G. GOGGI and D. SCANNICCHIO

Istituto di Fisica dell'Università - Pavia
Istituto Nazionale di Fisica Nucleare - Gruppo di Pavia

G. MARINI

Istituto di Fisica dell'Università - Roma
Istituto Nazionale di Fisica Nucleare - Sezione di Roma

F. MASSA and F. VANOLI

Istituto di Fisica Superiore dell'Università - Napoli
Istituto Nazionale di Fisica Nucleare - Sezione di Napoli

(ricevuto il 9 Ottobre 1970)

Summary. — Multiple particle production in electron-positron interactions has been observed in an experiment performed at Adone, the Frascati 2×1.5 GeV e^+e^- storage ring. A total number of 239 events collected at several energies of the incident electron and positron beams between 0.8 and 1.0 GeV were analysed. The distribution of the multiplicity of charged particles produced in the final state is discussed and some upper limits on these multiplicities are reported. The observed lower limit to the total cross-section for multiple particle production in e^+e^- interactions, averaged over the energy range explored, is $3 \cdot 10^{-32}$ cm² with a statistical error of $\pm 10\%$ and a systematic uncertainty of $\pm 25\%$.

Multiple particle production in e^+e^- interactions has been observed at Adone, the Frascati 2×1.5 GeV e^+e^- storage ring ⁽¹⁾. The measured cross-

⁽¹⁾ F. AMMAN *et al.*: *Proceedings of the International Conference on High-Energy Accelerators* (Dubna, 1963), p. 249; F. AMMAN *et al.*: *Proceedings of the V International*

section appears to be of the order of $3 \cdot 10^{-32}$ cm², at energies of the incident electrons and positrons between 0.8 and 1.0 GeV.

The experimental apparatus (see Fig. 1) is described in a previous paper ⁽²⁾. We recall that it consists of four equal independent telescopes $T_1 \dots T_4$, surrounding the vacuum chamber in a straight section of the machine and covering ~ 0.35 of the total solid angle. In each telescope T_i there are four scintillation counters A_i , B_i , C_i and D_i , and two magnetostrictive monogap wire chambers α_i and β_i . A thick absorber (~ 22 cm of Fe) and cosmic-ray veto counters (CR) lie above the apparatus.

A charged particle in telescope T_i is defined as

$$T_i \equiv A_i B_i (C_i + D_i),$$

while a neutral particle N_i corresponds to the coincidence

$$N_i \equiv (\bar{A}_i + \bar{B}_i)(C_i + D_i).$$

A «master» event is given by the coincidence between at least two charged particles detected by two telescopes, without a veto signal from the CR counters.

For each event, the following information is recorded:

i) the time of the event with respect to a signal in phase with the machine radio-frequency (R.F.);

ii) the co-ordinate, orthogonal to the beam direction, of two points along the trajectory of a particle in each triggered telescope (it should be noted that we do not measure co-ordinates along the direction of the beam in wire chambers α_i and β_i and, when two simultaneous sparks occur in the same chamber, we only read the one closest to the magnetostrictive pick-up);

iii) the four pulse heights H_i , each H_i being the sum of the pulse heights in counters C_i and D_i . (Both C_i and D_i are shadowed by a 0.7 cm Pb absorber.)

In what follows, as in ref. ⁽²⁾, we will call « π » or « μ » the particles giving a pulse height H_i in the range from $H_{i,\min}$ to $H_{i,\max}$ corresponding to a min-

Conference on High-Energy Accelerators (Frascati, 1965), p. 703; F. AMMAN *et al.*: *Proceedings of the International Symposium sur les Anneaux de Collisions* (Saclay, 1966), III-2-1; F. AMMAN, R. ANDREANI, M. BASSETTI, M. BERNARDINI, A. CATTONI, V. CHIMENTI, G. F. CORAZZA, D. FABIANI, E. FERLENGHI, A. MASSAROTTI, C. PELLEGRINI, M. PLACIDI, M. PUGLISI, F. SOSO, S. TAZZARI, F. TAZZIOLI and G. VIGNOLA: *Lett. Nuovo Cimento*, **1**, 729 (1969).

⁽²⁾ B. BARTOLI, B. COLUZZI, F. FELICETTI, V. SILVESTRINI, G. GOGGI, D. SCANNICCHIO, G. MARINI, F. MASSA and F. VANOLI: *Nuovo Cimento*, **70 A**, 603 (1970).

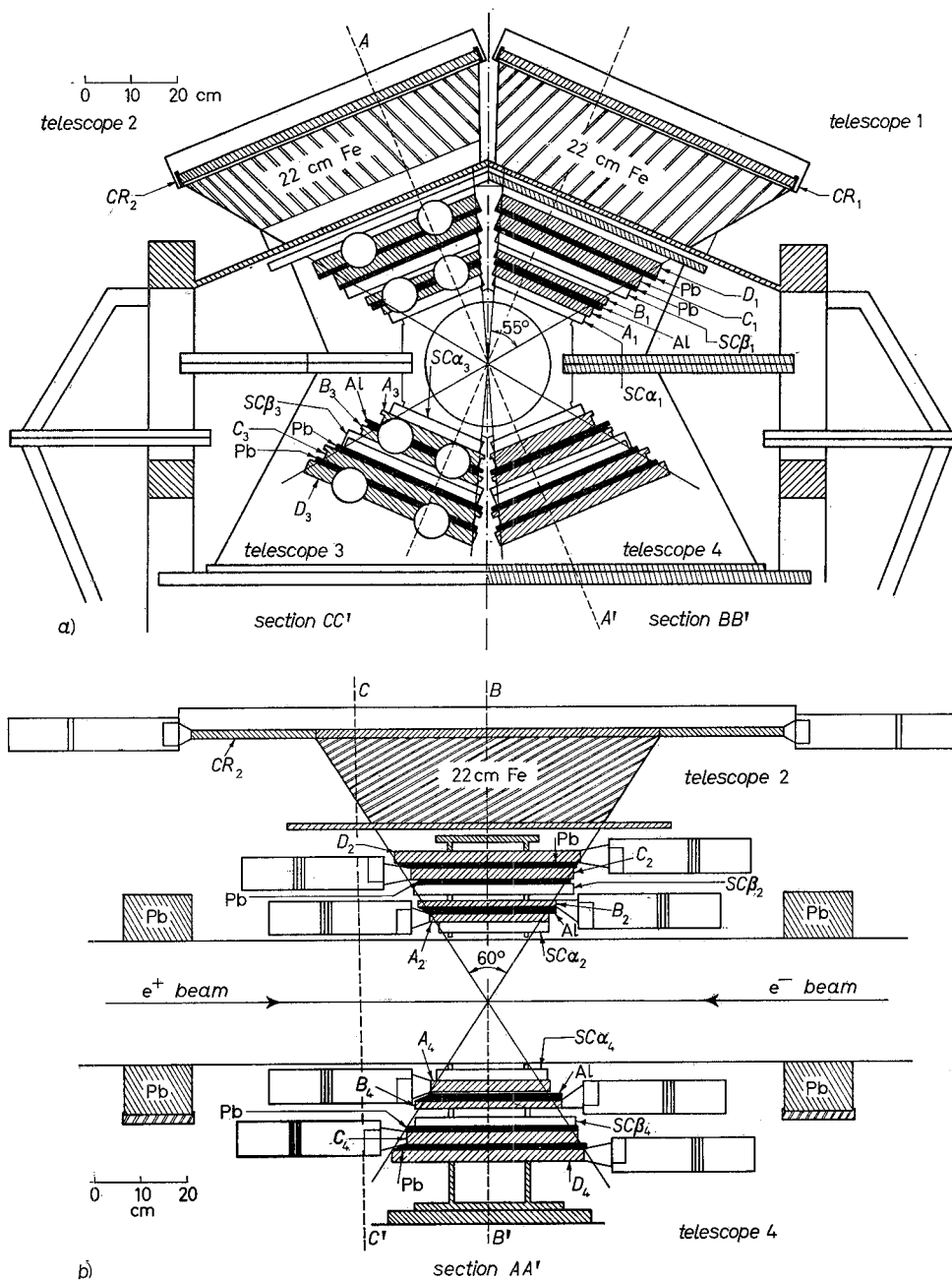

Fig. 1. - The experimental apparatus. a) Section orthogonal to the beam axis: A_i, B_i, C_i, D_i are plastic scintillator counters; $SC\alpha_i$ and $SC\beta_i$, magnetostriuctive monogap wire chambers; CR_1 and CR_2 , the veto counters for cosmic rays. b) Section in a plane through the beam direction and orthogonal to a pair of opposite telescopes.

imum ionizing particle, and «e» those whose pulse height is larger than $H_{i,\max}$. φ_i indicates the angle between the plane, parallel to the beam direction, containing the outgoing particle and a horizontal plane. L_i is the perpendicular distance between the line of flight of a particle in the telescope T_i and the axis of the beam. (The sign of L_i specifies on which side of the beam the particle crosses the horizontal plane.) Finally $\Delta\tau$ is the time between the occurrence of the event and the centre of the beam-beam collision time interval.

In the present paper we discuss the experimental results regarding «noncoplanar» events, namely the ones satisfying at least one of the following requirements:

more than two charged particles (with $H_i > H_{i,\min}$) in the final state, each traversing a different telescope, are detected;

only two charged products (with $H_i > H_{i,\min}$) are observed, but with $|\Delta\varphi| \geq 12^\circ$, $\Delta\varphi$ being the angle between the planes parallel to the beam direction and containing the lines of flight of the emitted particles.

First of all we classify the events as having occurred in time with the beam bunch collision, or out of time with it. Figure 2 shows the spectrum of the number of events as a function of Δt . Δt is the time separation between the occurrence of the event and a reference time fixed with respect to the phase of the R.F. accelerating voltage of the storage ring. The range of Δt corresponding to the e^+ and e^- bunch collision changes slightly with the energy, as is expected, since the synchronous phase of the bunches is a function of the machine energy.

It appears from the results presented in the right-hand column of Fig. 2 that the «e-e» events (*i.e.* the ones in which two outgoing particles give rise to a shower) have practically no cosmic-ray background contamination. Thus they can be used in order to define clearly the beam-beam collision interval of Δt at each energy. Therefore we can classify the noncoplanar events in two categories; we will call «in phase» events (p.e.) the ones occurring during the collision time of the e^+ and e^- bunches ($|\Delta\tau| \leq 4$ ns), and the remainders «out of phase» events (o.p.e.) which turn out to be essentially cosmic-ray background.

Most «noncoplanar» p.e.'s appear to originate in the centre of the straight section of Adone. This is seen, graphically, in Fig. 3 where the plots of L_i vs. L_j ($i < j$) for p.e. and o.p.e. are shown. i and j are the indices indicating the telescopes triggered in a given event. In Fig. 3a) p.e. are plotted and they appear to be clustered around the origin. Figure 3b) shows the corresponding distribution for the o.p.e. Here the points uniformly cover the plane, as would be expected for cosmic-ray particles.

Figure 4 shows the projection on the axes of the plot in Fig. 3a). In Fig. 4a), which shows the projection of all the events on the L_i -axis, there is

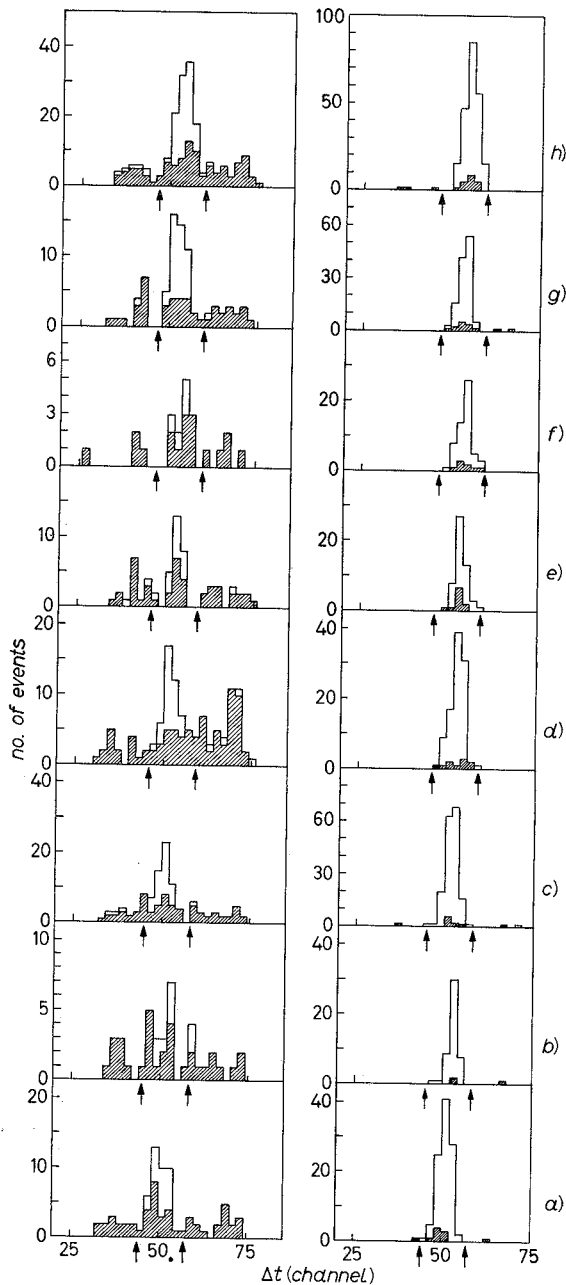

Fig. 2. - Time distribution of the events for several values of the total c.m. energy $2E = E_+ + E_-$. Δt is the time distance between the occurrence of the event and a reference time fixed with respect to the phase of the radio-frequency (R.F.) accelerating voltage of the storage ring (1 channel ~ 0.7 n.s). Right-hand side spectra refer to Bhabha events, left-hand side spectra refer to «noncoplanar» ones. The white area corresponds to events coming from the «source» (see Fig. 3 and 4), the hatched area to all the others.

a) $2E = 1600$ MeV, b) $2E = 1650$ MeV, c) $2E = 1700$ MeV, d) $2E = 1750$ MeV, e) $2E = 1800$ MeV, f) $2E = 1850$ MeV, g) $2E = 1900$ MeV, h) $2E = 2000$ MeV.

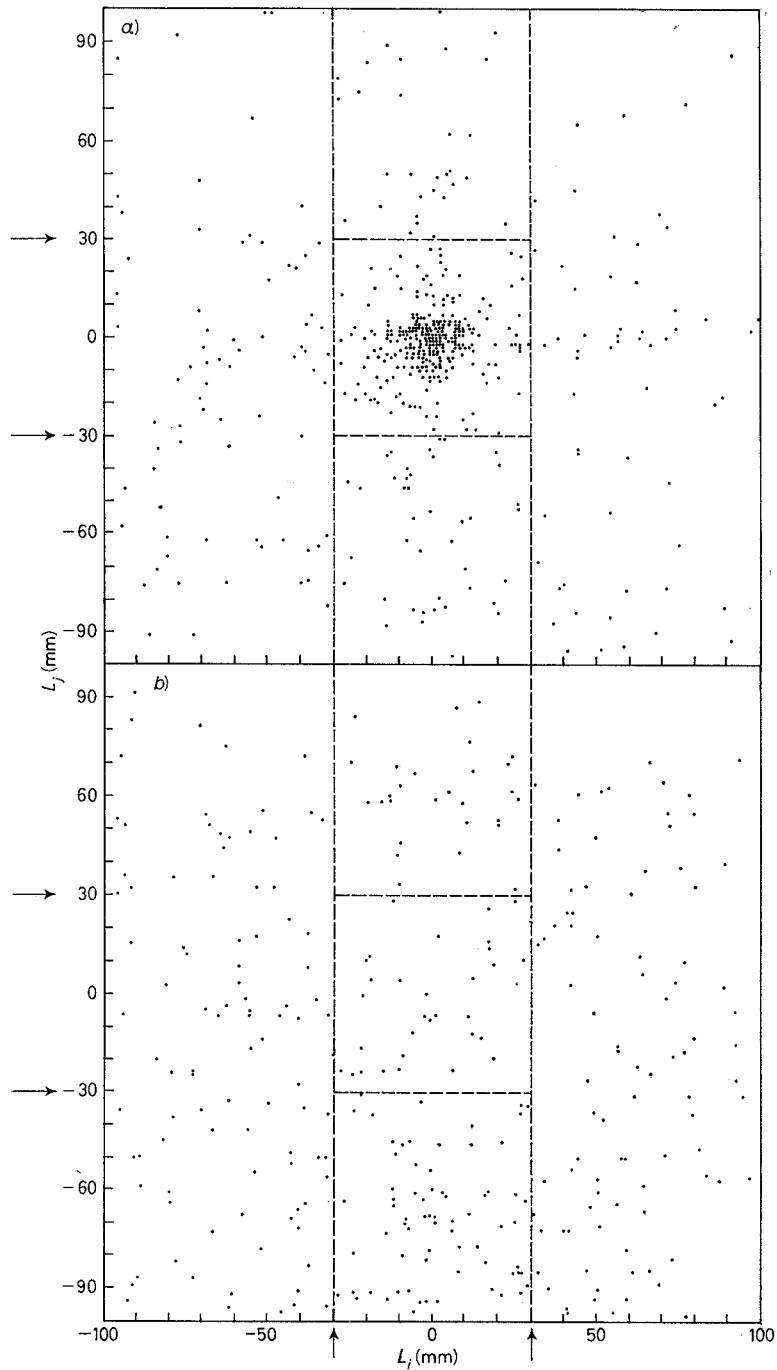

Fig. 3. - Plots of L_i vs. L_j for noncoplanar events. $L_{i(j)}$ is the distance between the line of flight of the particle in the telescope $T_{i(j)}$ and the axis of the beam. *a*) Events which are in phase with the bunches (p.e. $|\Delta\tau| \leq 4$ ns). *b*) Out-of-phase events (o.p.e., $|\Delta\tau| > 4$ ns).

an evident peak, superimposed on a smooth background. The shape of this background can be obtained from the plot of Fig. 3b) and its projected distribution, normalized by the appropriate time factor, is also shown in Fig. 4a) as

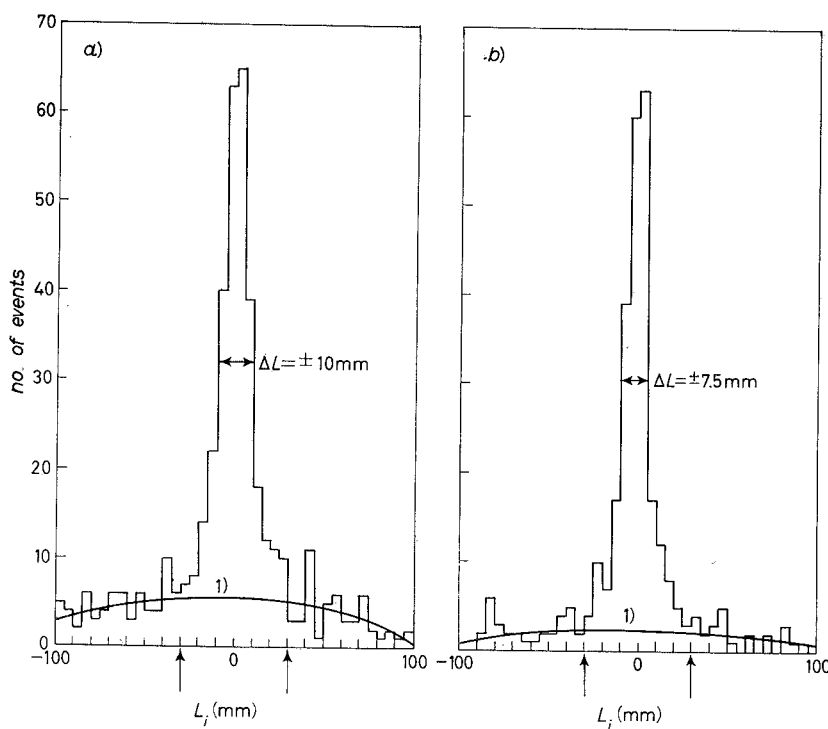

Fig. 4. - Projections of the plot of Fig. 3a). *a)* All the events of Fig. 3a) are projected on the L_i axis. Curve 1) cosmic-ray background; amount of background within ± 30 mm $\simeq 22\%$. *b)* The events for which $|L_i| \leq 30$ mm are projected on the L_j axis. The cosmic-ray background curves are obtained by appropriately normalizing the projections of the plot of Fig. 3b). Curve 1) cosmic-ray background; amount of background within ± 30 mm $\simeq 10\%$.

« cosmic-ray background ». In Fig. 4b), only the events with $|L_i| \leq 30$ mm are projected into the L_j -axis; the same peak of Fig. 4a) is now superimposed on a smaller background. We define events « from the source » (s.e.) the ones for which both $|L_i|$ and $|L_j|$ are less than or equal to 30 mm. From Fig. 4b) it results that s.e. contain only $\sim 10\%$ contamination in the form of a smooth background, essentially due to cosmic rays.

The number of noncoplanar « in phase » events from the source is listed in Table I for several different values of the total c.m. energy $2E = E_+ + E_-$. It should be noted that, in the present analysis of noncoplanar events, we required that all of the four spark chambers involved in each event showed

TABLE I.

$2E = E_+ + E_-$ (GeV)	Total running time (hour)	Integrated luminosity (cm^{-2})	Collected noncoplanar events inphase with the bunches (p.e.) and from the source (s.e.)				« e-e » events collected at the same time
			Events with 2 charged products only	Events with 2 charged products + neutrals	Events with 3 charged products + possible neutrals	Total number of p.e., s.e. noncoplanar events detected	
1	2	3	4	5	6	7	8
2.00	104.6	$250 \cdot 10^{32}$	72	3	1	76	203
1.90	60.4	$132 \cdot 10^{32}$	26	1	4	31	107
1.85	33.1	$94 \cdot 10^{32}$	4	0	0	4	46
1.80	63.5	$116 \cdot 10^{32}$	21	1	1	23	97
1.75	74.1	$105 \cdot 10^{32}$	18	4	2	24	89
1.70	78.1	$116 \cdot 10^{32}$	30	3	3	36	157
1.65	56.5	$82 \cdot 10^{32}$	18	5	1	24	95
1.60	60.8	$73 \cdot 10^{32}$	16	1	4	21	95
Total	531.3	$968 \cdot 10^{32}$	205	18	16	239	889
Normalized cosmic-ray background			-20.5 ± 2.9	-1.8 ± 0.25	-1.6 ± 0.22	-23.9 ± 3.3	
Normalized e ⁻ -gas interaction background			-31.1 ± 7.7	0	0	-31.1 ± 7.7	
Total number of p.e., s.e., noncoplanar events after background subtraction			153.4 ± 16.5	16.2 ± 4.2	14.4 ± 4.0	184.0 ± 17.6	

a track. Since the single monogap efficiency has been measured to be ~ 0.85 to 0.90 , this criterion results in a rejection of $\sim 40\%$ of the events.

The number of the events in which only two charged products are detected is listed in column 4 of Table I. In column 5 the number of those with two charged prongs, along with at least one neutral particle N_i in another telescope, is given. Column 6 contains the number of events with three observed tracks, and, since our spark chambers are able to detect only one track at a time, three different telescopes must have been involved. The 7th column is the sum of columns 4, 5 and 6, *i.e.* the total number of noncoplanar events that were recorded.

To avoid corrections due to the spark chamber inefficiency, we also have selected the « e-e » wide-angle elastic-scattering events, collected at the same time and in which all of the four spark chambers involved in each event showed

a track. These are listed in the last column of Table I and will be used later for normalization purposes.

Further information on the nature of the detected noncoplanar events has been obtained from the analysis of the pulse heights H_i .

In Fig. 5c) we give a typical distribution of H_i 's for noncoplanar « in phase » events from the source. The pulse height distributions for minimum ionizing (cosmic rays) and showering (« e-e ») particles are shown for purposes of comparison in Fig. 5a) and b). The noncoplanar events appear to be essentially minimum ionizing particles although they show a nonnegligible tail ($\sim 20\%$) at larger pulse heights (the « e » region). This tail may be accounted for by the following effects:

i) the possible presence of another charged or neutral particle in the same telescope, which can be estimated from Table I to be $\sim 7\%$;

ii) nuclear interactions;

iii) the probability for a minimum ionizing particle to give a $H_i \geq H_{i,max}$;

iv) the possibility that detected particles have $\beta \ll 1$.

Moreover two-dimensional H_i vs. H_j pulse-height plots do not show any correlation between the energy loss of the different outgoing particles from each event. This can also be seen by comparing the distributions of hatched and white histograms in Fig. 5c) (see caption).

Finally in Fig. 6a) the distribution of the angles $|\Delta\varphi|$ for noncoplanar events is shown. They appear to be distributed over all angles from $\sim 10^\circ$

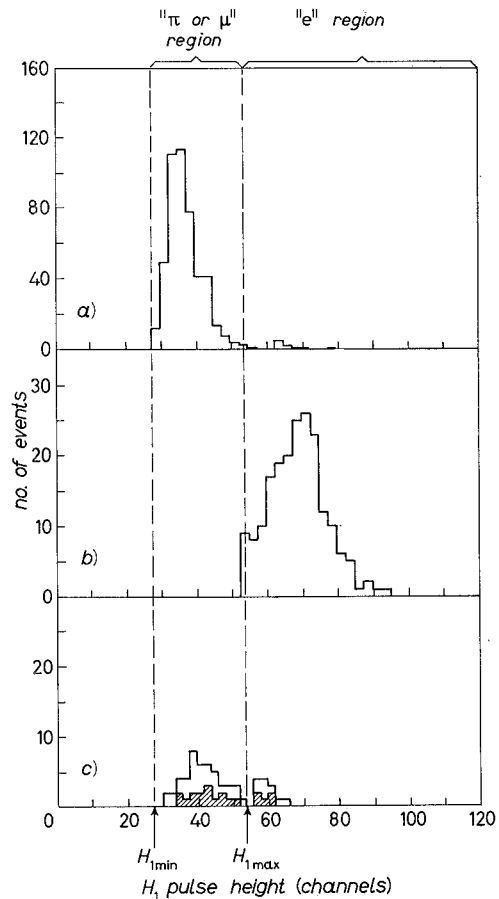

Fig. 5. - Pulse height distributions in telescope T_1 . a) Minimum ionizing particles (cosmic rays). b) Bhabha events. c) Noncoplanar events, which are in phase with the bunches (p.e., $|\Delta\tau| \leq 4$ ns) and originate in the source (s.e., $|L_i|$ and $|L_j| \leq 30$ mm). The hatched histogram corresponds to the events for which a particle in the telescope T_1 is accompanied by a particle whose pulse height falls in the « e » region.

to 180° . In this same Figure the hatched histogram refers to the events in which one or more particles fall in the above-mentioned large-pulse-height tail; their angular distribution is quite similar to the one for all events.

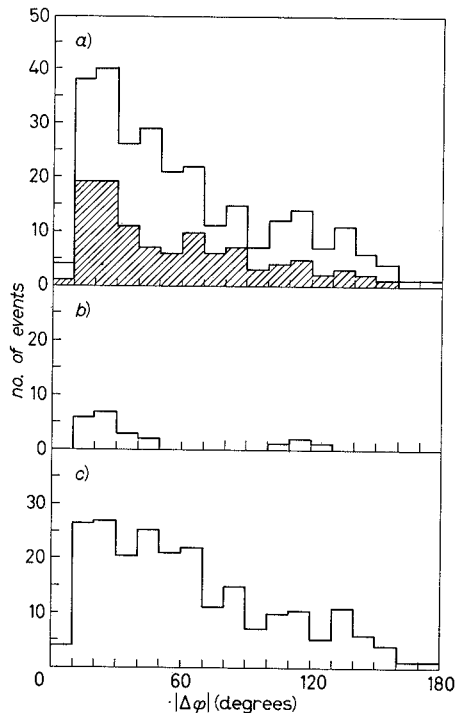

Fig. 6. — Distribution of $|\Delta\varphi|$ for p.e., s.e. noncoplanar events. a) $|\Delta\varphi|$ distribution for events from two-beam runs. Hatched events have at least one particle whose pulse height falls in the «e» region. b) $|\Delta\varphi|$ distribution for events from one-beam (e^-) runs (beam-gas interaction background). c) Difference between the $|\Delta\varphi|$ distribution when two beams are circulating in the machine and the distribution for the beam-gas background runs properly normalized. The normalization is discussed in the text.

We will now evaluate the contamination due to the interaction of the beams with the residual gas in the machine. The information registered by the apparatus in its present configuration does not allow us to reject this kind of background event by event. Therefore, we have performed «background» runs with only one beam (e^-) circulating in the machine; the beam energies at which observations were made were $E=1.0, 0.875$ and 0.850 GeV. In these background runs we collected 21 events, meeting the same requirements as the ones used in the selection of our sample of p.e., s.e., noncoplanar events. (During the same running period we expected 2.7 ± 0.4 events of this kind due to cosmic rays.) All 21 observed events had only two charged prongs (*i.e.* they are similar to the events listed in column 4 of Table I). Their $|\Delta\varphi|$ distribution is shown in Fig. 6b).

In order to subtract the correct contribution of electron-gas interactions from our data, we must deduce the appropriate normalization factor to be applied to these background events. The value of this normalization factor has been obtained by monitoring the rate of each telescope T_i during both the background and the two beam runs. Actually the counting rates

of the T_i 's, after cosmic-ray subtraction, are directly associated with the interaction of the beams with the residual gas in the machine. This fact has been checked by simultaneous measurements of the single telescope rates T_i 's and the single beam-gas bremsstrahlung rate B . The ratio T_i/B was found constant to within 1% as a function of the beam intensity and gas pressure over the

working range of this experiment. It turns out that the measured background must be multiplied by a factor of 1.7 in order to be able to be directly subtracted from the data as given in Table I. It should be noted that the same value is obtained regardless of which of the telescopes T_i is used as a basis for the normalization, even though the counting rates in each are quite different due to their relative position with respect to the machine. Moreover, a scaling of the background using the direct measurement of beam currents and pressure in the vacuum chamber agrees with the previously determined normalization factor of 1.7.

By performing this background subtraction we obtain the corrected, non-coplanar, s.e., p.e., $|\Delta\phi|$ distribution shown in Fig. 6e) (the e⁻-gas background that was subtracted totalled $\sim 13\%$).

The experimental results are summarized in Table II. Listed in column 2 are the total numbers of the detected noncoplanar events, which are in phase with the bunches (p.e.) and originate in the source (s.e.). Column 3 contains the number of cosmic-ray background events: this amounts to a total of 10% of all events, and is distributed among the different energies in proportion to the time devoted to data collection. In column 4 the number of non-coplanar events recorded in the one-beam runs is given. The 5th column gives the normalized number of beam-gas background events, from which cosmic-ray events were subtracted. The normalization factors were obtained from the T_i counting rates recorded at each energy.

TABLE II.

$2E = E_+ + E_-$ (GeV)	p.e., s.e., non-coplanar events detected	Background			p.e., s.e. non-coplanar events after background subtraction	$N_{\geq 2}$ p.e., s.e. non-coplanar events	N_0 corresponding corrected wide-angle scattering events	$R = \frac{N_{\geq 2}}{N_0}$
		Cosmic-ray background events	Detected e ⁻ -gas interaction background	Normalized e ⁻ -gas interaction background events				
1	2	3	4	5	6	7	8	9
2.00	76	4.8 ± 0.6	13	12.0 ± 3.0	59.2 ± 9.2	110.0 ± 17.2	254.4 ± 18.4	0.432 ± 0.075
1.90	31	2.7 ± 0.4		3.8 ± 1.0	24.5 ± 5.7	45.4 ± 10.6	136.1 ± 13.4	0.333 ± 0.085
1.85	4	1.5 ± 0.2		1.5 ± 0.4	1.0 ± 2.0	1.9 ± 3.7	58.6 ± 8.8	0.032 ± 0.064
1.80	23	2.9 ± 0.4		4.6 ± 1.1	15.5 ± 4.9	28.9 ± 9.1	122.5 ± 12.7	0.236 ± 0.079
1.75	24	3.3 ± 0.5	3	3.3 ± 0.8	17.4 ± 5.0	32.5 ± 9.3	113.1 ± 12.2	0.287 ± 0.088
1.70	36	3.5 ± 0.5	5	2.9 ± 0.7	29.6 ± 6.1	55.3 ± 11.4	201.8 ± 16.3	0.274 ± 0.061
1.65	24	2.5 ± 0.3		2.0 ± 0.5	19.5 ± 4.9	36.4 ± 9.1	121.9 ± 12.6	0.299 ± 0.081
1.60	21	2.7 ± 0.4		1.0 ± 0.2	17.3 ± 4.6	32.3 ± 8.6	122.7 ± 12.6	0.233 ± 0.066
Total	239	23.9 ± 3.3	21	31.1 ± 7.7	184.0 ± 17.6	343.6 ± 37.9	1131.0 ± 39.5	0.304 ± 0.03

By subtraction of the numbers in column 3 and 5 from those in column 2 we obtain the number of background-subtracted noncoplanar events. These are given in column 6.

Corrections must be applied to these numbers. These corrections, however, depend upon the nature of the observed particle. On the assumption that we are dealing with pions, we have evaluated the fraction of undetected events caused by the following effects:

i) particles which suffer nuclear interactions and do not produce a trigger in telescopes T_i : $(29 \pm 5)\%$;

ii) particles with insufficient energy to trigger the telescopes T_i 's: $(7 \pm 3)\%$ ⁽³⁾;

iii) losses due to particles giving anticoincidence counts in CR veto counters: $(13.5 \pm 5)\%$ ⁽³⁾;

iv) events rejected because of the noncoplanarity criterion, *i.e.* $|\Delta\varphi| < 12^\circ$: $(10 \pm 3)\%$.

The numbers of noncoplanar events after correction for these effects are listed in column 7 of Table II.

For the purpose of normalization, we list in column 8 of Table II the numbers of e^+e^- wide-angle elastic-scattering events collected at the same time as the multiparticle events and selected with the same criteria for chamber efficiencies. These numbers were obtained from Table I column 7 after applying the following corrections (see ref. ⁽²⁾ for a complete discussion of these corrections):

i) $(+16 \pm 2)\%$ for inefficiency in the detection of e.m. showers;

ii) $(+ 8 \pm 4)\%$ due to losses caused by coincidence counts in CR veto counters;

iii) $(+3 \pm 3)\%$ for geometrical misalignment of the apparatus with respect to the beam. (This correction is negligible for noncoplanar events.)

Losses due to multiple scattering are almost the same for $e^+e^- \rightarrow e^+e^-$ and noncoplanar events and so no corrections were applied to either.

⁽³⁾ The absorbers in the telescopes T_i and in front of the CR counters set the following limits on the kinetic energy T of the observed particles: $\sim 80 \text{ MeV} \lesssim T \lesssim 350 \text{ MeV}$. The evaluation of the corresponding corrections (due to their smallness) does not critically depend on the momentum distribution of the emitted particle; we have used the experimental momentum distribution of pions from $p\bar{p} \rightarrow 2\pi^+ + 2\pi^-$ annihilations (see, *e.g.*, C. BALTAY, P. FRANZINI, G. LÜTJENS, J. C. SEVERIENS, D. TYCKO and D. ZANELLO: *Phys. Rev.*, **145**, 1103 (1966)).

The last column of Table II gives the ratios $N_{\geq 2}/N_0$ of the number of corrected noncoplanar events to the number of $e^+e^- \rightarrow e^+e^-$ events.

We would now like to extract from our experimental data information on the cross-sections and multiplicities of the reaction

$$e^+ + e^- \rightarrow (\text{two charged particles}) + (\text{at least one charged or neutral particle}).$$

The cross-section for this multiple particle production process can be estimated from a knowledge of the detection efficiency of the experimental apparatus ε . Actually, for a given final state f , the cross-section σ_f is given by

$$(1) \quad \sigma_f = \frac{1}{\mathcal{L}} \frac{N_f}{\varepsilon_f} = \frac{\sigma_{\text{eff}}(e^+e^-) N_f}{N_0 \varepsilon_f},$$

where N_f is the experimental number of detected events of the type f , N_0 is the number of $e^+e^- \rightarrow e^+e^-$ scattering events collected at the same time, \mathcal{L} is the corresponding integrated luminosity of the machine ⁽⁴⁾, ε_f is the detection efficiency for the chosen final state f , and $\sigma_{\text{eff}}(e^+e^-)$ is the Bhabha cross-section integrated over the solid angle of our apparatus.

Now, if $\sigma(n)$ is the cross-section for producing n charged particles (possibly accompanied by neutrals) in e^+e^- interactions, the number $N_{\geq 2}$ ($N_{\geq 3}$) of events with ≥ 2 (≥ 3) detected tracks is given by

$$(2) \quad \begin{cases} N_{\geq 2} = \sum_{n=2,4,6\dots} \varepsilon_{\geq 2}(n) \cdot \mathcal{L} \cdot \sigma(n), \\ N_{\geq 3} = \sum_{n=4,6\dots} \varepsilon_{\geq 3}(n) \cdot \mathcal{L} \cdot \sigma(n), \end{cases}$$

where $\varepsilon_{\geq 2}(n)$ ($\varepsilon_{\geq 3}(n)$) is the efficiency of the apparatus for the detection of

TABLE III.

n	2	4	6
$\varepsilon_{\geq 2}(n)$	2.9%	15.1 %	33.2%
$\varepsilon_{\geq 3}(n)$	0	1.45%	6.4%

⁽⁴⁾ We recall that the luminosity \mathcal{L} (essentially the product of the e^+ and e^- beam intensities divided by their effective section) is a measurement of the machine intensity. The number of events produced is directly given by the product $\mathcal{L} \cdot \sigma$, where σ is the cross-section of the process.

two or more (three or more) charged particles out of the n charged products of the reaction.

The values for $\varepsilon(n)$ were calculated under the assumption that particles are emitted isotropically in the reaction. Values for $\varepsilon(n)$ corresponding to an average « source » length of $2\bar{l} = 40$ cm ⁽⁵⁾ are given in Table III.

Obviously the value of these efficiencies is model dependent. However, as the source and detector lengths are almost equal and as the total multiplicities involved are relatively high ⁽⁶⁾, the dependence on the particular production model should be weak. The lack of any hint at a more sophisticated model at this stage makes the use of the simplest one a reasonable choice.

If we disregard charged multiplicities $n \geq 8$, eqs. (2) become

$$(3) \quad \begin{cases} N_{\geq 2} = (\varepsilon_{\geq 2}(2) \cdot \sigma(2) + \varepsilon_{\geq 2}(4) \cdot \sigma(4) + \varepsilon_{\geq 2}(6) \cdot \sigma(6)) \cdot \mathcal{L} , \\ N_{\geq 3} = (\varepsilon_{\geq 3}(4) \cdot \sigma(4) + \varepsilon_{\geq 3}(6) \cdot \sigma(6)) \cdot \mathcal{L} . \end{cases}$$

By properly correcting the experimental numbers of Table I for the losses due to the effects we listed above (nuclear absorption, probability for a particle to be vetoed by the CR counters, etc.) we can obtain the experimental value of the ratio $N_{\geq 3}/N_{\geq 2}$. The value of this ratio averaged over all beam energies turns out to be

$$\frac{N_{\geq 3}}{N_{\geq 2}} = (9.5 \pm 2.8) \% .$$

Equating this value to the ratio of eqs. (3) and using the efficiencies given in Table III calculated under the assumption that particles are emitted isotro-

⁽⁵⁾ Our « source » has a finite longitudinal dimension and is expected to have a Gaussian distribution $N(l) = N_0 \exp[-l^2/2\bar{l}^2]$. Theoretically \bar{l} is expected to be $\bar{l}(\text{cm}) = 20E_{\pm}^{\frac{1}{2}}$ and experimentally has been measured to be $\bar{l}(\text{cm}) = (22 \pm 2)E_{\pm}^{\frac{1}{2}}$, where E_{\pm} is in GeV. (Private communications from the Adone machine staff.) As far as the $\varepsilon(n)$'s are concerned, their dependence on \bar{l} is $\varepsilon(n) \propto l/\bar{l}$, but since our conclusions involve only ratios of $\varepsilon(n)$'s they are independent of the actual value used for \bar{l} .

⁽⁶⁾ Also in the case $n = 2$ the total number of charged and neutral particles produced in the reaction must be ≥ 3 . In order to estimate how model dependent the values of the efficiencies ε 's are, we have calculated the ε 's for several simple cases. If two charged pions are emitted ($n = 2$), depending on the number of the associated π^0 's, the values of the ε 's obtained with the statistical model can be $\sim 30\%$ larger than the values given in Table III which were calculated under the assumption that the particles were emitted isotropically. For the higher charged multiplicity states ($n > 2$) the values of Table III agree to better than $\sim 10\%$ with the results one can obtain with any reasonable hypothesis.

pically, we can put an upper limit to the fraction of events produced with $n=6$:

$$\frac{\sigma(6)}{\sigma(2) + \sigma(4) + \sigma(6)} \leq \frac{\varepsilon_{\geq 2}(2)}{(N_{\geq 2}/N_{\geq 3})\varepsilon_{\geq 3}(6) + \varepsilon_{\geq 2}(2) - \varepsilon_{\geq 2}(6)} = (8_{-3}^{+8})\%.$$

This limiting value corresponds to the extreme situation in which a charged multiplicity of $n=4$ is totally absent (*i.e.* $\sigma(4)=0$), and it is obtained assuming that the distribution of multiplicities is almost constant in the energy range explored, *i.e.* $1.6 \text{ GeV} \leq 2E \leq 2.0 \text{ GeV}$. The fact that a charged multiplicity of $n=6$ occurs less than $\sim 10\%$ of the time, justifies *a posteriori* the initial assumption that we could neglect charged multiplicities $n \geq 8$.

From the present experimental information it is not possible to extract the relative magnitude $\sigma(4)$ and $\sigma(2)$. The experimental value $N_{\geq 3}/N_{\geq 2} = (9.5 \pm 2.8)\%$ is also compatible with the extreme situation in which only an $n=4$ charged multiplicity is present. Actually when $\sigma(2)=\sigma(6)=0$ the expected value of $N_{\geq 3}/N_{\geq 2}$ is $\varepsilon_{\geq 3}(4)/\varepsilon_{\geq 2}(4) \sim 10\%$ (see Table III). In this case the average value of the cross-section would turn out to be $\sigma(4) \sim 3 \cdot 10^{-32} \text{ cm}^2$.

Since our experimental detection efficiency for the $n=2$ mode, $\varepsilon_{\geq 2}(2)$, is very small in comparison with the value of $\varepsilon_{\geq 2}(4)$ (see Table III), and since it is quite probable that some events with $n=2$ exist, a larger value for the total cross-section $\sigma = \sigma(2) + \sigma(4) + \sigma(6) + \dots$ for multiple particle production (most likely hadrons) in e^+e^- interactions could result.

Now we can try to make a more quantitative estimate. If we neglect the contribution (less than $\sim 10\%$ of the total) from charged multiplicities $n \geq 6$, and if we apply the relationship $N_e = \mathcal{L} \cdot \sigma_{\text{eff}}(e^+e^-)$, we obtain from the first of equations (3)

$$(4) \quad k \cdot \sigma(4) = \frac{N_{\geq 2}}{\mathcal{L} \cdot \varepsilon_{\geq 2}(4)} = \left(\frac{N_{\geq 2}}{N_e} \right) \cdot \frac{\sigma_{\text{eff}}(e^+e^-)}{\varepsilon_{\geq 2}(4)},$$

where

$$k = 1 + \frac{\sigma(2)}{\sigma(4)} \frac{\varepsilon_{\geq 2}(2)}{\varepsilon_{\geq 2}(4)}.$$

Using the values for ε given in Table III, k is found to be

$$k = 1 + \frac{\sigma(2)}{\sigma(4)} \cdot \frac{1}{5.2},$$

which is not very different from 1 unless $\sigma(2)/\sigma(4) \gg 1$. For instance, if $\sigma(2) \sim \sigma(4)$, $k = 1.19$, and $\sigma(4)$ would be $\sim 15\%$ smaller than the value of $k \cdot \sigma(4)$. In this case the corresponding total cross-section for multiple particle production ($\sigma = \sigma(2) + \sigma(4)$) would result in a value $\sim 70\%$ larger than $k \cdot \sigma(4)$.

The experimental values of $k \cdot \sigma(4)$, obtained from eq. (4) by using the ratios $N_{\geq 2}/N_e$ listed in column 9 of Table II, are shown in Fig. 7 as a function of the total c.m. energy $2E = E_+ + E_-$ (⁷). The value of $k \cdot \sigma(4)$ averaged over the explored range of energy, turns out to be

$$\langle k \cdot \sigma(4) \rangle = (3.1 \pm 0.3) \cdot 10^{-32} \text{ cm}^2,$$

where the error comes only from statistics. The evaluation of the corrections and the calculation of the efficiencies may introduce an additional systematic uncertainty of $\sim \pm 25\%$.

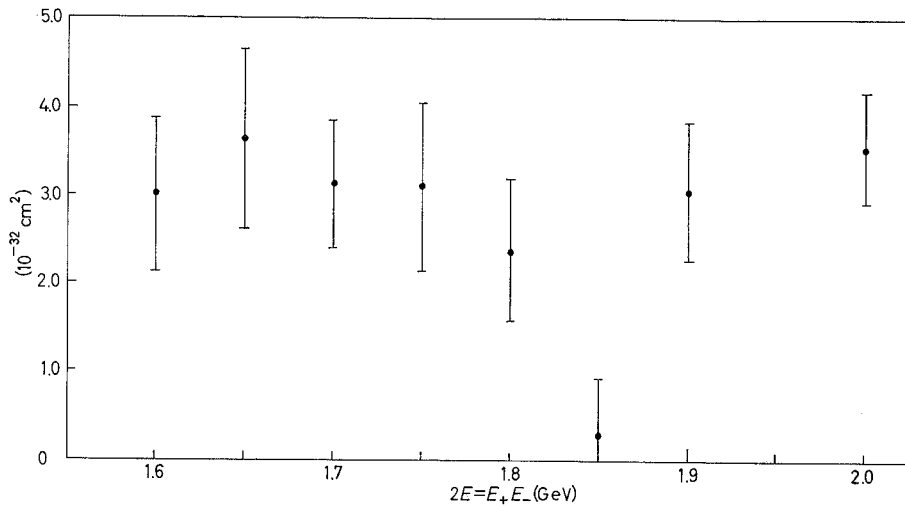

Fig. 7. - The product $k \cdot \sigma(4)$ is plotted as a function of the total c.m. energy $2E = E_+ + E_-$; $k(\geq 1)$ is given by $k = 1 + (\sigma(2)/\sigma(4))(1/5.2)$, and $\sigma(n)$ is the cross-section for producing n charged particles (+ possible neutrals), see text.

From the previous considerations, the value $3 \cdot 10^{-32} \text{ cm}^2$, with a statistical error $\pm 10\%$ and within a systematic uncertainty of $\pm 25\%$, can be taken as a lower limit for the total cross-section for multiple particle production in e^+e^- interactions, averaged over the energy range explored (*i.e.* $1.6 \text{ GeV} \leq 2E \leq 2.0 \text{ GeV}$).

(⁷) In eq. (4) both $\sigma_{\text{eff}}(e^+e^-)$ and $\epsilon_{\geq 2}(4)$ depend on the average length $2\bar{l}$ of the source, but their ratio is almost independent of it.

To give a feeling of how large the cross-sections of Fig. 7 are, we recall the following cross-sections calculated for $2E = 1.8$ GeV:

$$\sigma_{\text{th}}(e^+e^- \rightarrow \mu^+\mu^-) = 2.7 \cdot 10^{-32} \text{ cm}^2,$$

$$\sigma_{\text{th}}(e^+e^- \rightarrow B\bar{B}) = 0.7 \cdot 10^{-32} \text{ cm}^2$$

(B being a spin-zero pointlike charged boson).

* * *

We would like to thank Prof. C. BERNARDINI, who participated during the design and beginning stages of the experiment, for his continuous interest and for many interesting discussions, and the machine staff for their friendly collaboration. We are particularly indebted to our technician G. SCHINA for his invaluable work in setting up and maintaining the apparatus. We are very grateful to Dr. A. RAMBALDI, who greatly aided us in using our PDP 8 tapes on the Univac 1108 computer and who willingly collaborated with us in many programming problems.

RIASSUNTO

In un esperimento eseguito con Adone, l'anello di accumulazione per elettroni e positroni da 2×1.5 GeV dei Laboratori Nazionali di Frascati, è stata osservata la produzione, nelle interazioni elettrone-positrone, di stati finali a molte particelle. In questo lavoro si presenta l'analisi di 239 eventi raccolti a varie energie dei fasci incidenti fra 0.8 e 1.0 GeV. Si discute la distribuzione delle molteplicità delle particelle cariche nello stato finale e si danno i limiti superiori per alcune di queste molteplicità. Il limite inferiore per la sezione d'urto totale di produzione di stati finali a molte particelle nelle interazioni e^+e^- , mediata nell'intervallo di energia esplorato, risulta essere $3 \cdot 10^{-32} \text{ cm}^2$ con un errore statistico del $\pm 10\%$ ed una incertezza sistematica del $\pm 25\%$.

Резюме не получено.