

LNF - 69/67
31 Ottobre 1969

M. Coli and B. Stella : HIGH SENSITIVITY DOUBLE ON LINE
QUANTAMETER FOR BUBBLE CHAMBER EXPERIMENTS. -

Laboratori Nazionali di Frascati del CNEN
Servizio Documentazione

LNF-69/67

Nota Interna: n. 456
31 Ottobre 1969

M. Coli and B. Stella: HIGH SENSITIVITY DOUBLE ON LINE QUANTA-
METER FOR BUBBLE CHAMBER EXPERIMENTS. -

SUMMARY. -

One on line quantameter for low intensity γ rays beam operation is described having two measuring channels for internal control; one for counting of the γ quanta of the beam and the other for the integral measurement of the beam intensity.

The detector was a lead converter followed by a plastic scintillator. The results are digitally displaced on the chamber pictures. Big efforts were made to achieve stability of the system against aging and ambient temperature.

2.

The quantameter herein described was designed as a part of the electronic equipment for experimentation with a bubble chamber operating on a γ ray beam.

This equipment performs the following functions:

- magnetic field-strength measurement,
- counting of the γ quanta of the beam,
- integral measurement of the beam intensity,
- beam energy spectrum distribution,
- optimal intensity selection (triggering for the picture recording when the intensity is between an allowed interval, pulse by pulse).

The first three functions, cyclically activated, are recorded on the chamber pictures, each every three frames. The energy spectrum measurement is registered on a multichannel analyzer and printed apart.

This paper refers about the two systems of quantametry with hints to the parts whose functions are common.

In previous bubble chamber experiments^(1, 2) with photons beams the beam intensity measurements was performed utilising as a monitor a well known reaction (e^+e^- pairs production). The procedure requires a very long and tedious work of scanning and calculation. Furthermore the beam intensity must be drastically reduced for the need of counting the traces at the minimum.

As a consequence, for instance, in the MIT⁽¹⁾ experiment no more than 4 pairs per frame typical was accepted corresponding to a beam intensity of ~ 40 equivalent quanta per pulse.

The system we have used detects the photons passing through the chamber by mean of a lead converter followed by a scintillation counter. So we have obtained an "on line" quantameter and we think of being able to accept up to ~ 50 pairs per frame, corresponding in our case to ~ 1500 e. q. per pulse.

The γ rays converter is a lead absorber 2.5 cm (~ 5 radiation lengths) thick, set up at the output of the chamber (~ 2 m far from the magnet). The thickness was designed with the following purposes:

- to achieve the maximum of the multiplicity (the maximum of the converting efficiency),
- to achieve the best energy resolution (for the spectrum analysis),
- to achieve the best linearity (for the spectrum analysis).

Figg.1 and 2 shows the shower curves diagrams (the multiplicity vs energy) in the lead for electrons of any energy (v. Fig. 1, Buja⁽³⁾) and of energy > 10 MeV (v. Fig. 2, Crawford and Messel⁽⁴⁾). In

Pb SHOWERS GENERATED BY PHOTONS (BUJA, 1963)

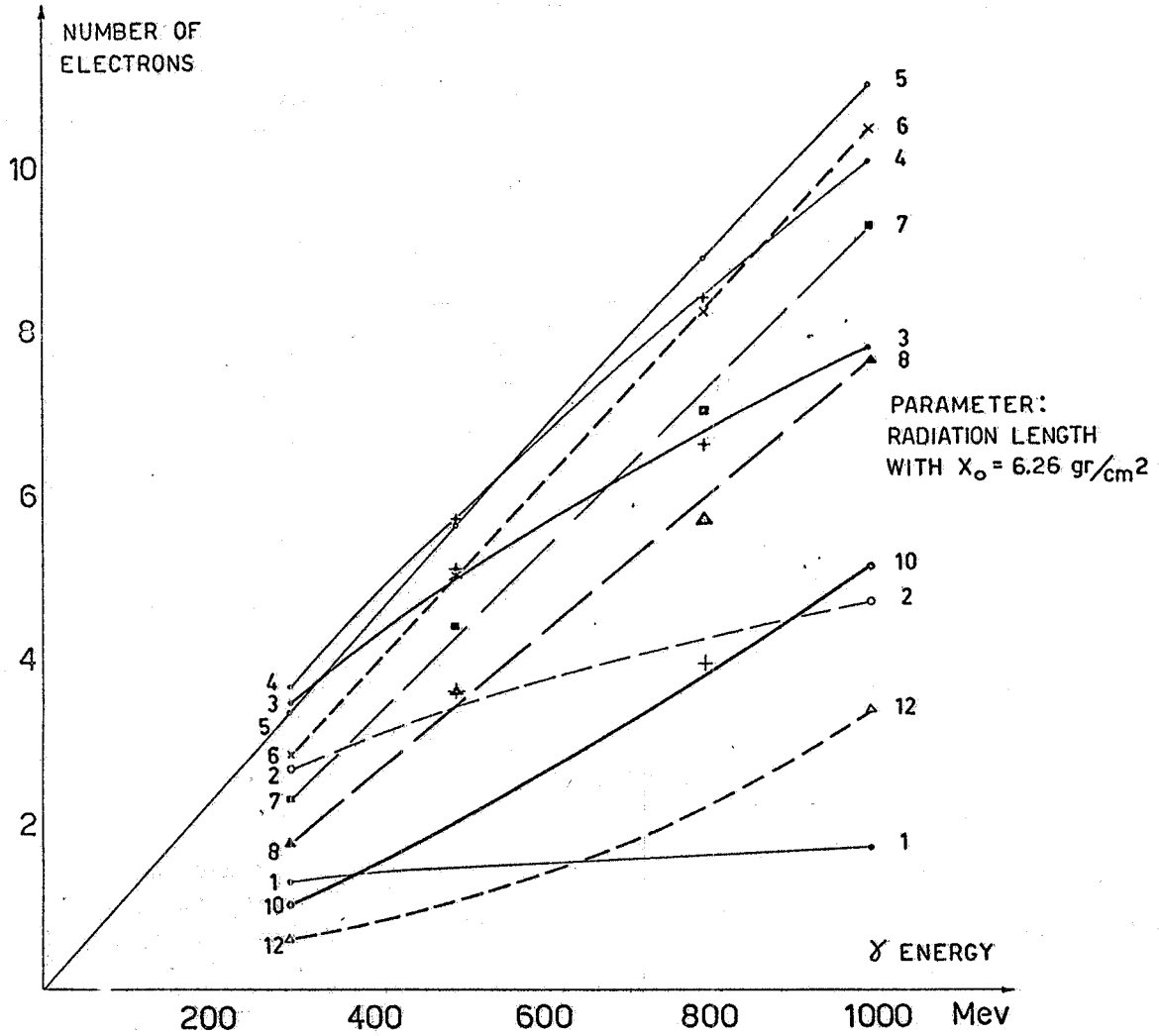

FIG. 1 - Pb showers generated by photons: charge multiplicity versus incident γ energy, the converter thickness as a parameter. The data have worked out by the authors from the quoted reference.

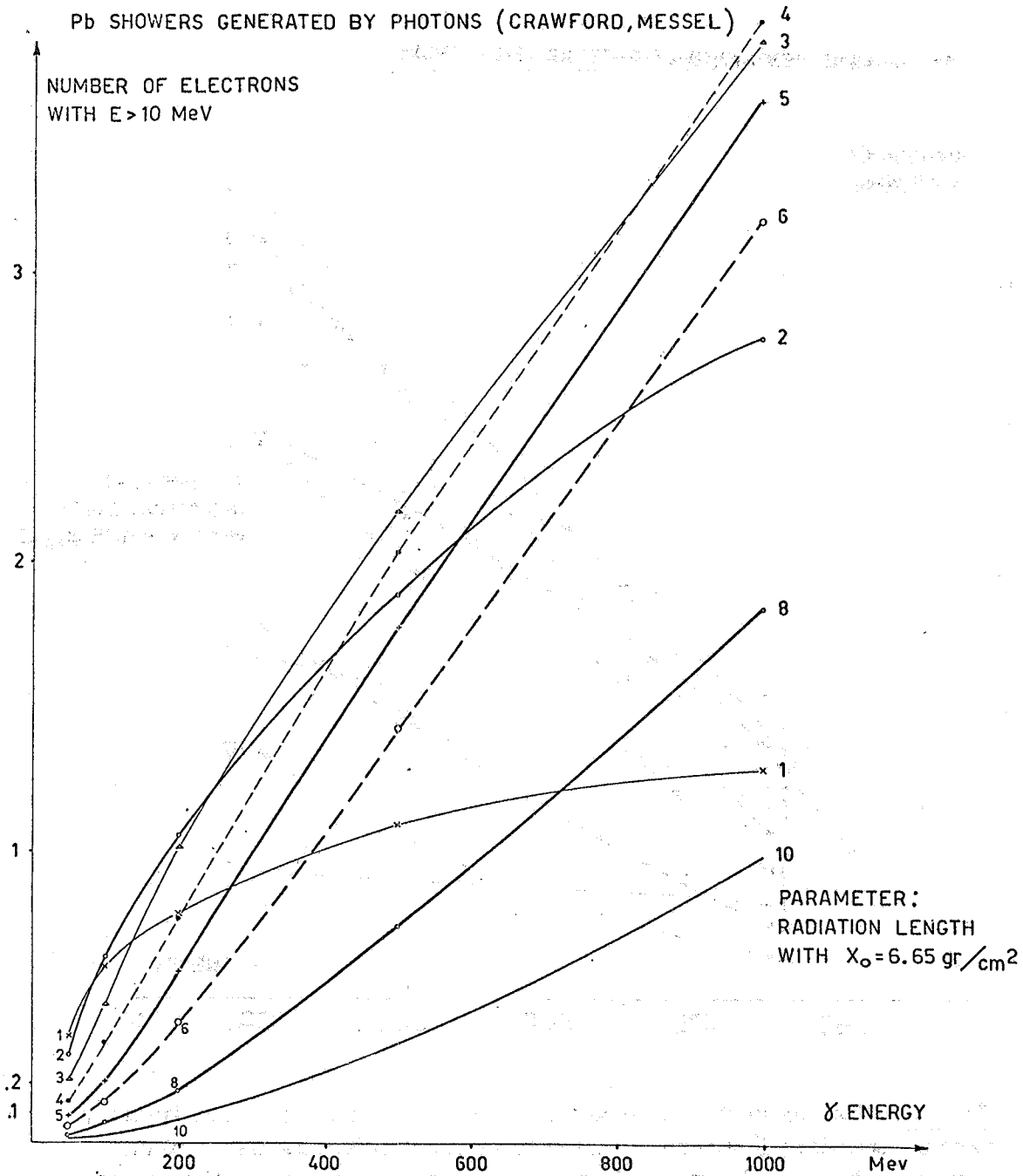

FIG. 2 - Pb showers generated by photons: charge multiplicity versus incident γ energy, the converter thickness as a parameter. The data have worked out by the authors from the quoted reference.

both cases, as we can see, the curve for 5 radiation lengths is the best compromise.

A single plastic scintillator (1 cm thick) is sufficient to perform all functions. In fact the spurious counting are irrelevant due to the low duty cycle of the beam pulses (beam pulse width 25 μ s, medium rate 1 pulse per second). Then only one gain stabilization chain for a P.M. PHILIPS 6810 was used by an automatic control system. The output pulses are analyzed in two channels, one for counting purpose and the other for integration and digital display.

The circuit schematic and the working checks and calibration are in the following.

CIRCUIT SCHEMATIC. - (see Fig. 3)

The output pulse of the main P.M. is fed, through a buffer circuit, to the fan-out F.O. 1 and F.O. 2. The input to the F.O. 2 is delayed of 60 ns with respect to the input of F.O. 1. The output pulses of F.O. 1 trigger the timing circuitry: the output pulses of F.O. 2 (delayed) are those belonging to the measuring channel.

The main timing circuit is a monostable (3) that enables the measuring channels only during the time duration of the beam. The trigger action of this monostable is enabled by the peaker pulse of the synchrotron to avoid spurious triggering during the absence of the beam.

The leading edge of the dead-time generator, triggered with the output pulse of F.O. 1, shifts one position of the main selector circuit (4) whose output pulses cyclically enable the measuring channels for the analog and digital quantametry and for magnetic field intensity measurement. The selector position is read-out on a NIXIE indicator either on the front pannel or on the remote read-out to be recorded on the corresponding bubble chamber picture.

The NIXIE read-out of the selector position is alligned with the three decade display NIXIES of the output counter, that is with the digital display of the apparatus.

a) - Counting of the beam γ -rays. -

The output pulses from F.O. 2 are shaped through a fast-discriminator circuit (6). The discriminator threshold is fixed to a level that allows the maximum counting frequency compatible with the output counter, in any case higher than the amplitude of the background pulses from the P.M.

The discriminator is gated during the beam time duration by a pulse shaping monostable (7) triggered by one of the main selector pulse.

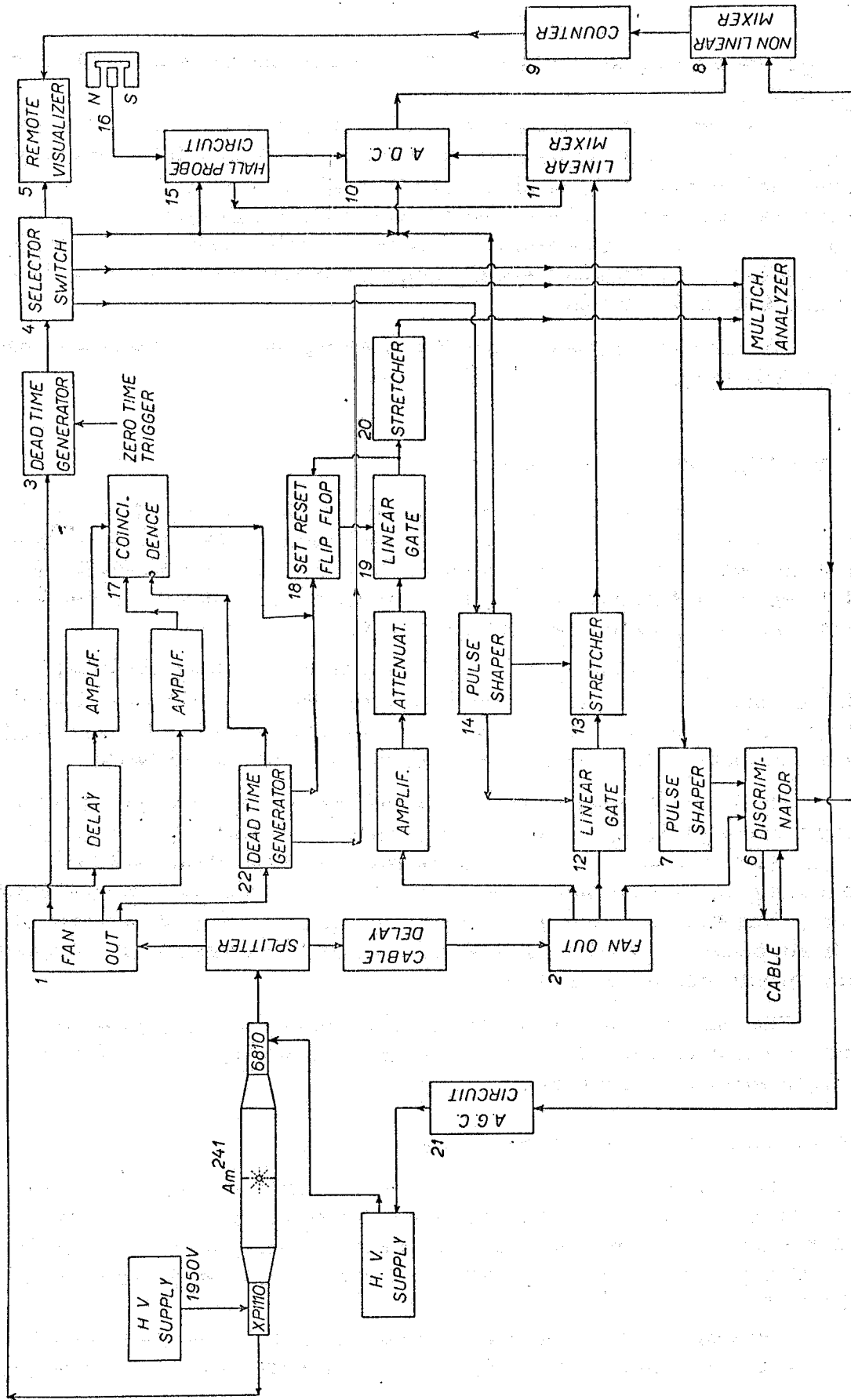

FIG. 3 - Block diagram of the electronics.

The output counter is fed through a fan-in circuit (8) splitting the pulses to be totalized from either the output of the discriminator or the analog quantameter and the magnetic-field intensity measurements channel.

The counter is an integrated circuit able to totalise up to 10 MHz input pulses repetition rate. Its read out is on the front pannel of the instrument and is repeated on a NIXIE read-out focalized in the field of the cameras of the bubble chamber and alligned with the NIXIED selector position indicator, as mentioned before.

b) - Measurement of the integral charge induced by the beam γ -rays. -

The integral beam intensity gauge is derived from one of the F.O. 2 outputs. The pulse burst from the P.M. is passed through a linear gate circuit (12) to an integrator (13) that converts the total area of the pulses in an analog level to be fed to the A-D converter. The measure is controlled by mean of a gate generator (14) triggered by the main selector output pulse. This gate generator feeds: a $100\mu\text{s}$ wide pulse to enable the linear gate: a $300\mu\text{s}$ wide pulse to the integrator circuit to allow its settling to the final value of the analog output level: finally a $100\mu\text{s}$ delayed pulse, $300\mu\text{s}$ width, to enable the A-D converter. The analog level from the integrator (13) is fed to the A-D converter through the linear mixer (11).

The A-D converter delivers a train of pulses during the time ($200\mu\text{s}$) it remains open after the triggering from the gate generator (14).

The pulse train reaches the counter through the fan-in (8). The read-out of the counter is then proportional to the difference of the analog level from the integrator, i. e. to the beam intensity, and a fixed bias E_1 . The fixed bias E_1 accounts for the lower threshold (under which the cameras were not triggered) corresponding to the P.M. background.

The beam intensity is then digitally memorized on the films output of the cameras.

c) Magnetic-field intensity gauge. -

The magnetic-field intensity is measured by means of a Hall probe which is biased by a pulsed current generator.

The output pulse of the channel selector (4), when on the stated position, activates the current generator with a pulse $100\mu\text{s}$ wide for the Hall probe.

The output pulse from the Hall probe is then amplified and fed to the A-D converter, ready after a prepulse from the selector itself.

8.

The cyclic recording of the three different measurements allows a large compactness of all the equipment together with a great economy of circuitry without altering appreciably the meaning of the results being gathered.

d) - Measurements precision and stability of the equipment. -

The precision of the measurements have been greatly increased by mean of two different stabilization chains: one for the P.M. gain and the other for the ambient temperature.

The need of P.M. gain stabilization is rather obvious⁽⁵⁾. For the bubble chamber experiments the stabilization has been judged useful providing that a measurement of the beam-energy spectrum has been planned.

The P.M. gain stabilization chain is shown in the schematic with circuits numbered from 17 to 21. The signals reference source for the chains is an Am^{241} α source whose mean-life (458 years) is very long with respect to the experiment duration.

The α particles emitted by the source are detected by the two P.M., a 6810 (measuring P.M.) and a XP 1110 (auxiliary P.M.) at the output of the coincidence (17). The strength of the source furnishes a rate of 300 pulses per second. Those pulses trigger the bistable gate pulse generator (18) opening the linear gate (19) of the linear analysing chain for either the α particles and the beam energy spectrum analysis. The input pulse for the later measure is derived from the F.O. 2 (delayed).

After the pulse lengthener (20) the output pulses are averaged in the circuit 21 and the analog level is sent to control the H.T., power supply of the P.M. 6810.

If the P.M. gain remains constant the averager circuit (21) gives a constant output level proportional to the source strength.

If either the P.M. or the control chain gain varies, the output level of the averager modifies the power supply voltage of the P.M. to maintain a constant pulse amplitude at its output.

The time constant (~ 2 minutes) of the averager must be sufficiently long to ensure that the statistical fluctuations of the counting rate gives a negligible contribution.

The gain stabilizing chain is inhibited during the beam duration utilizing as anticoincident pulse the output of a special dead time generator (22) for the linear measuring channel.

The operating temperature of the equipment has been stabili-

zed settling the circuits in a crate ventilated with air at the temperature of 30°C controlled by a thermostat.

The temperature stabilization is within 1°C for ambient excursions of 15-20°C.

e) - Beam energy spectrum measurement. -

The linear measuring channel used to stabilize the P.M. gain is utilized during the beam pulse to measure its energy spectrum.

The output pulse of the dead time generator (22) sets the bistable gate generator (18) that is reset by the first pulse at the output of the linear gate (19).

The output pulse of the lengthner (20) is fed to the multichannel analyzer (23) opened in coincidence with the output pulse of the dead-time generator (22) for the beam energy spectrum analysis or optionally in anticoincidence with the same pulse for the α particles spectrum control as a check of the effectiveness of the linear channel stabilization.

WORKING CHECKS AND CALIBRATION. -

The linearity of single circuits and of the complete chains, together with the operating performance of the overall system, have been checked by means of a beam pulses simulating circuit giving a pulse-train with variable frequency, amplitude, and repetition rate. The checking conditions are similar to the working conditions except as concerning the random fluctuations in amplitude and time.

The response of the analog and digital chains have been found in those conditions as linear as permitted by the operating limits of the single circuits, and stable during the whole time of checking in any case.

The long term stability (~ 250 consecutive hours) has been checked operating the system with the γ beam, and measuring the lines position of the Am^{241} ; its stability was of one channel that, is $\sim 10^{-2}$ Volt, under 1 V of mean amplitude.

The final check of the linearity and the calibration have been exploited "a posteriori" comparing the output of the quantameter recorded on each individual picture with the corresponding number of pairs produced in the fiducial volume.

The first results refer to a total number of 1200 frames (400 for the counting and 400 for the integration) on a film taken at a rather low beam intensity (~ 12 traces per frame).

The frames on which the counting has been recorded have been

10.

utilized for calibration. The results are shown in Fig. 4 following the procedure as below:

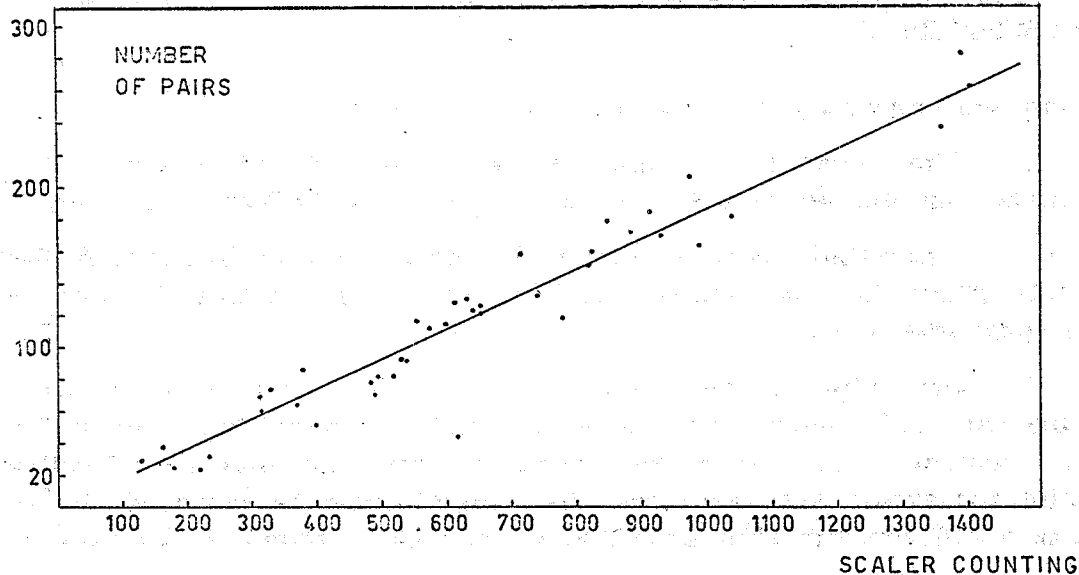

FIG. 4 - Preliminary calibration curve (see text for explanation).

1) The values of the x, y coordinates of the points plotted on the diagram have been obtained summing the counting and pairs number respectively on all frames whose registered counting was between predetermined intervals (an interval for each point). This procedure does not introduce any bias for it corresponds to totalize many beam pulses on a single frame, the beam intensity being additionable on a very large scale.

2) The fluctuation on the x variable has not been considered so that in the fitting procedure the x is the "true" variable.

3) On the diagram the least square error curve has been reported. It is a straight line defined as:

$$y = a + b(x - \bar{x})$$

where

$$\bar{x} = \frac{\sum x_i}{n} ; \quad a = \bar{y} = \frac{\sum y_i}{n} ; \quad b = \frac{\sum (x_i - \bar{x}) y_i}{\sum (x_i - \bar{x})^2}$$

We have obtained:

$$a = 114.5 \pm 3.0$$

$$b = 0.187 \pm 0.009.$$

4) The fitting can be checked verifying that the variable

$$T = \frac{y_i - Y_i}{S} \quad \text{with} \quad S = \frac{1}{n-2} \sum_{i=1}^n (y_i - Y_i)^2$$

has a normal distribution with mean value $m = 0$ and variance $\sigma^2 = 1$.

We have obtained:

$$m = 0.014 \pm 0.150$$

$$S^2 = 1.01 \quad (S^2 \text{ is the estimation of } \sigma^2).$$

We can note that no coincidence system has been set up to avoid the background counting of the plastic scintillator due to the cosmical and ambient radiation.

The calculation of the Bravais-Pearson correlation coefficient between the number of pairs and the scaler read-out frame by frame, on a random sample of 100 events gives the value about 0.2, corresponding to a 95 % probability of the two variables being correlated.

The results obtained, thought yet not sufficient, give the system calibration (knowing the cross section of the e^+e^- pairs photoproduction) with a good level of confidence.

ACKNOWLEDGEMENTS. -

The skilfull work of Mr. M. Avaltroni, together with the cooperation and useful discussion with the Frascati Bubble Chamber Group especially mentioning Prof. G. Gialanella are greatly acknowledged.

REFERENCES. -

- (1) - Cambridge Bubble Chamber Group, Phys. Rev. Letters 13, 636 (1964); and quoted references.
- (2) - Aachen, Berlin, Bonn, Hamburg, Heidelberg, München Collaboration, Nuovo Cimento 41, 270 (1966).
- (3) - Z. Buja, Acta Phys. Polonica 24, 381 (1963); Nukleonika 9, 389 (1964).
- (4) - D. F. Crawford and H. Messel, Nuclear Phys. 61, 145 (1965).
- (5) - C. Bacci, R. Baldini-Celio and V. Bidoli, Nuclear Instr. and Meth. 57, 100 (1967).