

LNF - 67/14
16 Marzo 1967

D. T. Grimsrud: A DC THERMOREGULATOR FOR LIQUID
HELIUM TEMPERATURES. -

(Nota interna : n. 355)

LNF - 67/14

Nota interna: n. 355
16 Marzo 1967

D. T. Grimsrud: A DC THERMOREGULATOR FOR LIQUID HELIUM TEMPERATURES. -

INTRODUCTION. -

Temperature control in a bath of a cryogenic fluid is obtained by regulating its equilibrium vapor pressure, i. e. by pumping on the bath. In this way heat energy removed by evaporation compensates for miscellaneous unavoidable sources of input energy. It is difficult to adjust the pumping speed to accommodate variations in the heat input. Therefore some other means of controlling the temperature is desired. A suitable technique involves the dissipation of an additional, controlled amount of energy in the bath while maintaining a constant pumping speed. Variations in input energy can then be compensated by adjustment of the added energy.

A number of devices have been described in the literature to do this⁽¹⁻⁵⁾. They typically involve a temperature sensing element, usually a carbon resistor in the bath, which constitutes the unknown resistance arm of a bridge. The unbalanced signal from the bridge is amplified and compared in phase with the signal exciting the bridge. Finally, the output of the phase detector closes the feedback loop by supplying power to a resistor located in the bath and used as a heater.

The purpose of this note is to describe the construction of a simple dc thermoregulator for use at liquid helium temperatures. The objectives and requirements of the thermoregulator include:

2.

- a) It must provide regulation above the lambda temperature of liquid helium where the low thermal conductivity of the bath makes electronic regulation difficult.
- b) The detector has to work with the low input powers required to accurately measure resistances of carbon resistors at liquid helium temperatures, i. e. powers of the order of 1 erg/sec.
- c) The influence of noise must be kept to a minimum.

THERMOREGULATOR DESIGN. -

The thermoregulator is designed around a Keithley Model 149 millimicrovoltmeter. This is a narrow-band chopper amplifier employing negative feedback to increase its input impedance. It has several useful features which enhance its applicability to the present problem. Its sensitivity ranges from 100 nanovolts to 100 millivolts in 13 steps. It has a zero suppress feature which permits the suppression of a background dc signal 100 times the full scale voltage being measured. The voltmeter acts as a dc amplifier with gains up to 10^8 .

Figure 1 gives a block diagram of the completed thermoregulator. The circuit diagram of the bridge is shown in Figure 2. It is a dc Wheatstone bridge using a mercury cell as its voltage source. The voltage divider reduces the voltage fed to the bridge to 0.027 volts. Thus at balance (assuming that the value of the carbon resistor in the bath, CR, is 1500 ohms) the power dissipated in CR is 1.2 ergs/sec.

The resistors used in the bridge are AT/AW Metallux thin-film resistors which have a temperature coefficient of resistance of less than 15 PPM/°C. A three-wire connection to the carbon resistor in the bath is used. With this type of connection one of the leads to CR is contained in the same bridge arm as CR while the other lead is in the arm with the standard decade resistors. Consequently, if we assume the leads to CR to be identical, any change in the resistance of the leads which occurs as the level of the helium bath falls will not affect the balance condition of the bridge⁽⁶⁾.

Figure 3 is the circuit diagram of the heater supply. This is a device to bias the output of the voltmeter and feed a measured current to the heater, R_H . A T-attenuator ($R_2 - R_{10}$) allows adjustment of the magnitude of the voltmeter component of the signal fed to the heater. The diode in the circuit prevents the system from changing from negative to positive feedback in the following sense. As the bath warms, the output of the voltmeter must subtract from the reference voltage in order to decrease the energy dissipated in R_H . If the bath is warm enough the voltmeter output will exactly cancel the reference voltage and energy dissipated in R_H will go to zero. If the bath warms

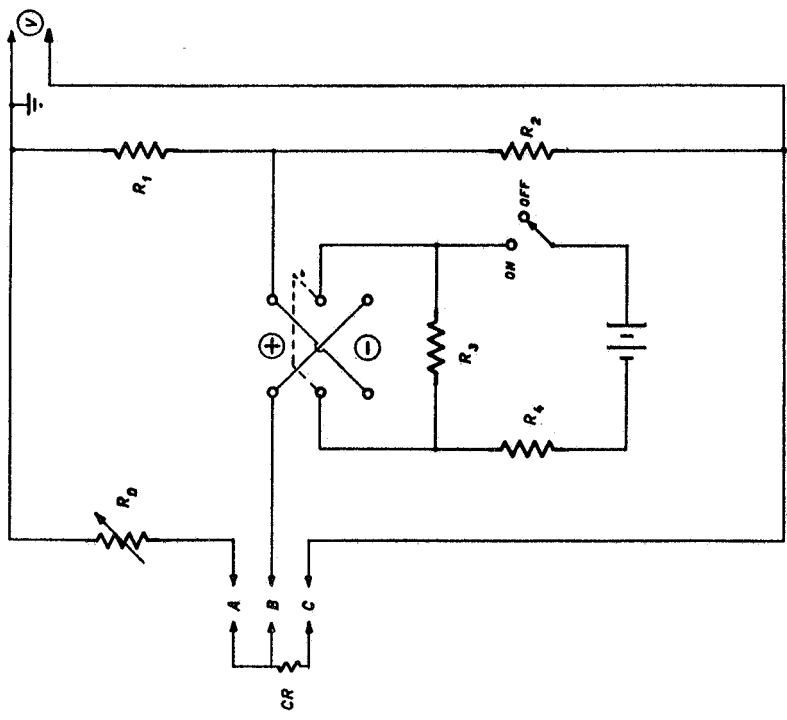

FIG. 2 - Circuit diagram of the bridge. The cell is a 1.36 v. mercury cell. The resistor values are (in ohms): $R_1 = R_2 = 2000$, $R_3 = 200$, $R_4 = 10000$. R_D is a standard resistor decade box.

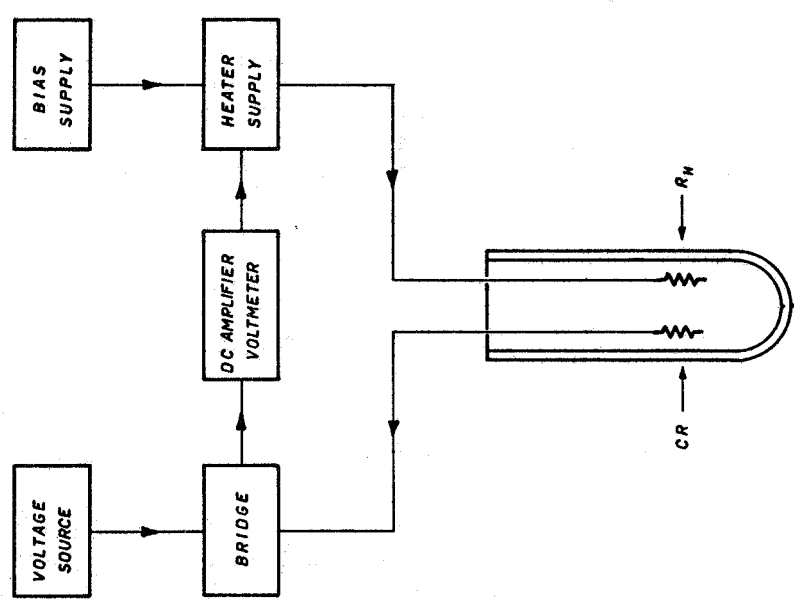

FIG. 1 - Block diagram of the completed thermoregulator.

4.

further and the diode were not present, the output of the voltmeter, overcompensating the reference voltage, would cause current in the heater resistor to begin to increase in the opposite sense. This would further warm the bath which would add more current, and we would have a thermal runaway effect.

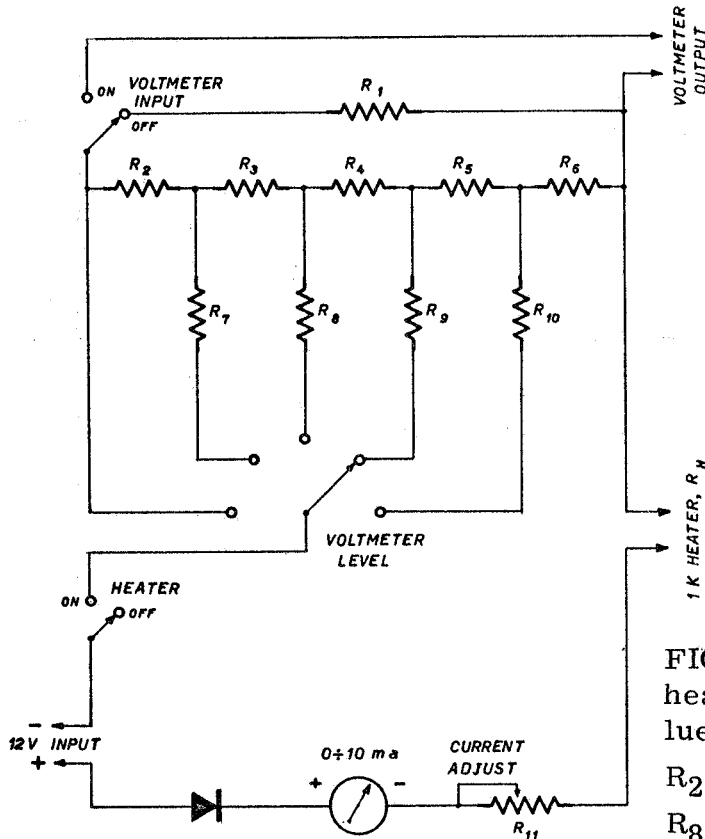
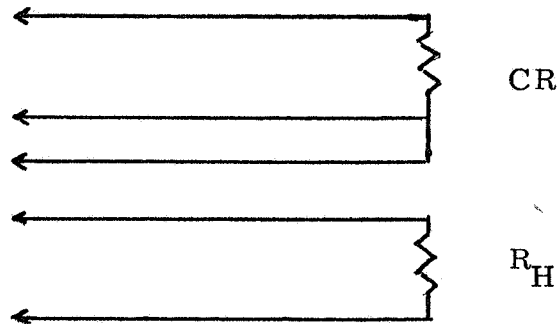

FIG. 3 - Circuit diagram of the heater supply. The resistor values are (in ohms): $R_1 = 100$, $R_2 = R_3 = R_4 = R_5 = R_6 = R_7 = 220$, $R_8 = 470$, $R_9 = 680$, $R_{10} = 820$, $R_{11} = 0 - 10000$.

The bias supply used is a Hewlett-Packard 6961A dc power supply. This has a stability of about 4 mv when used as a 12 volt supply.

NOTES ON THE USE OF THE THERMOREGULATOR. -

- A. Five leads (preferably of copper to minimize thermal emf's) are required between room temperature and the two resistors CR and R_H in the bath. CR should be a carbon resistor having a value approximately 1500 ohms in the temperature range in which the measurements are to be made. R_H should be a 1000 ohm wire-wound resistor. The lead connections must be made as shown below :



It is important to note that none of the leads can be grounded.

- B. Connect the heater to the jacks on the front panel of the heater supply marked "1 K HEATER".
- C. Connect CR to the three-terminal connector on the bridge. The two blue jacks of the cable are connected to one side of CR, the red jack to the other.
- D. The bridge is connected to the voltmeter at the BNC jack marked " V " on the bridge. Attach the red lead from the voltmeter input to the center terminal and the black lead to the outside, ground terminal.
- E. Ground the bridge at the ground terminal of the decade resistor box.
- F. A 12 v. dc power source is connected to the terminals marked "12 V INPUT" on the back of the heater supply. Observe polarity!
- G. The connection from the voltmeter output to the heater supply is made using the cable on the back of the voltmeter and attaching this to the proper terminals on the back of the heater supply. The cable and terminals are color-matched (green-green and white-white).
- H. With the voltmeter input switch turned off and the heater switch on, adjust the base current to the desired value.
- I. For stable operation the reversing switch on the bridge should be in the \oplus position. If operated in the \ominus position the thermoregulator will be functioning in a positive feedback mode.
- J. Bring the bridge to a rough balance, turn on the voltmeter input and complete the balance procedure.
- K. The sensitivity of the thermoregulator may be adjusted by changing the range of the voltmeter or by changing the voltmeter level switch on the front of the heater supply.
- L. Occasionally it is necessary to make adjustments for drift in the thermal emf. This can be done by switching the bridge voltage off and using the zero suppress on the voltmeter to balance any thermal emf observed.

6.

OBSERVED PERFORMANCE. -

The thermoregulator has been used successfully to stabilize bath temperatures in both HeI and HeII. In HeI regulation was measured to be ± 0.15 mdeg for periods up to one hour. In HeII the regulation was observed to be better than ± 40 μ deg for periods of approximately one hour. The noise on the signal is 0.05 μ volts.

The loop gain of the regulator operating with a voltmeter in put of 1.0 and on the 3 μ volt scale of the voltmeter is approximately 35 watts/ $^{\circ}$ K.

TROUBLE SHOOTING. -

Assuming all the power sources and the voltmeter are functioning properly the most likely source of problem is an improper ground connection. When this is present two things are likely to be observed:

- a) Voltages measured by the voltmeter do not agree when the range switch is changed.
- b) A portion of the voltage output is fed back electrically to the input of the voltmeter.

ACKNOWLEDGMENTS. -

The author would like to thank Dr. F. Scaramuzzi for suggesting the problem and for helpful discussions. He would also like to thank La Commissione Americana per gli Scambi Culturali con l'Italia for a Fulbright Grant during the period of this work.

NOTES AND REFERENCES. -

- (1) - W. S. Boyle and J. B. Brown, Rev. Sci. Instr. 25, 359 (1954).
 (2) - H. W. Sommers, Jr., Rev. Sci. Instr. 25, 793 (1954).
 (3) - C. Blake, C. E. Chase and E. Maxwell, Rev. Sci. Instr. 29, 715 (1958).
 (4) - H. Forstat and J. R. Novak, Rev. Sci. Instr. 29, 733 (1958).
 (5) - C. Blake and C. E. Chase, Rev. Sci. Instr. 34, 984 (1963).
 (6) - Actually this is true only if the ratio arm of the bridge equals unity. The balance condition for the bridge shown in Figure 2 is $CR = R_D \frac{R_2}{R_1} = R_D \alpha$ where α is the value of the ratio arm of the bridge. Consider two cases:

- a) If both leads to CR are included in the same bridge arm as CR, the balance condition is

$$CR = \alpha R_D - 2 R_1$$

where R_1 is the resistance of each of the lead wires.

- b) When one lead is in both the unknown and standard arms we have instead

$$CR = \alpha R_D - R_1(1 - \alpha)$$

Thus if condition b) is to be an improvement over condition a) we must have

$$\left| \frac{1 - \alpha}{2} \right| < 1 \quad \text{or} \quad \alpha < 3.$$

In the present bridge $\alpha = 0.9949$ so that the error caused by lead resistor changes is reduced by a factor of 400.