



LABORATORI NAZIONALI DI FRASCATI

SIS – Pubblicazioni

LNF-95/034 (P)

10 Luglio 1995

High Power μ s Pulsed Electrolysis Using Palladium Wires: Evidence for a Possible "Phase" Transition Under Deuterium Overloaded Conditions and Related Excess Heat

Francesco CELANI*, Antonio SPALLONE*, Paolo TRIPODI*, Alessandra PETROCCHI*,
Daniele Di GIOACCHINO*, Paolo MARINI**, Vittorio Di STEFANO**,
Sandro PACE***, Alfredo MANCINI****,

*INFN–Laboratori Nazionali di Frascati, Via E.Fermi 40, I-00044 Frascati (Italy).

**EURESIS, V. Lero 40, 00144 Roma

***Dipartimento di Fisica, Università di Salerno, 84081 Salerno (Italy)

****ORIM S.R.L., Via Concordia 65, 62100 Macerata (Italy)

Abstract

In this paper we describe an electrolytic experiment aimed at reaching high deuterium concentration gradients in palladium wires, using the electromigration effect.

We will describe the selection criteria of experimental parameters and we will show results of our loading and calorimetric measurements. These tests reveal that a high mean value of D/Pd has been reached in a short time and that there is a correlation between an anomalous heat emission and an electric resistivity "transition" of the overloaded palladium.

PACS.: 52.80.-S

Invited paper at the "ICCF5", Montecarlo, 9 – 13 April, 1995
Publishing as Conference Proceedings ICCF5, World Scientific

Submitted to Physics Lett. A

1. Introduction

1.1 Coehn effect

In electrotransport the effect on the concentration variations within the palladium can be very large[1]: the deuterons are forced to move along the Pd cathode (deuterons current) because of the voltage drop caused by the flowing electron current into the wire. In this region the stationary state will be reached when the incoming deuterons are exactly compensated by the outward diffusion of deuterons across the wire surface. The actual deuterium concentration in such equilibrium state will result higher than in absence of the Coehn effect. In other words, Coehn effect could be helpful in increasing the D/Pd ratio. The parameter which mainly controls the rising up of deuterium concentration is the potential drop along the cathode; accordingly, in our tests we used a thin (0.1 mm) and long (up to 200 cm length) palladium wire, in which a very large (up to 80 A) pulsed current is flowing.

In a stationary state, the deuterium concentration at a fixed point x is given by [2] :

$$c(x) = c_0 e^{-eZ^* V(x) / K_B T} \quad (1)$$

where

- c_0 Initial concentration of H,D,T
- e Electron charge ($1.6 \cdot 10^{-19}$ C)
- $V(x)$ local electric potential
- Z^* "effective charge" of H,D,T in Pd
 $=1$ at low concentrations ($H/Pd < 0.6$) [1]
 $=0.1$ at high concentrations (>0.8) [3]
 and/or at high temperature
- K_B Boltzmann constant, $1.38 \cdot 10^{-23} \text{J} \cdot \text{K}^{-1}$
- T Temperature (K)

1.2 Debye-Falkenhagen-Sach effect

In an electrolytic solution with finite ionic concentration, for the principle of global as well as local neutrality, each ion is surrounded by an ionic atmosphere, which is globally of the opposite sign of the ion. In absence of an electric field the system ion-ionic atmosphere is symmetric.

When an electric field is applied to the solution, the ion is driven in one direction, while its atmosphere is driven in the opposite direction; therefore new ionic atmosphere must be continuously reconstructed around the moving ion. The time for reconstruction of the ionic atmosphere is called *relaxation time* and the retarding effect of the motion of the ion is said *asymmetry effect*. A further retarding effect is due to the resistance to the backward motion of the ionic atmosphere, which, by the way, contains molecules of water. This second effect is called the *electrophoretic effect*. The third retarding effect, which affects the motion of both the ion and its atmosphere is due to the viscosity of water.

The conductivity of an electrolytic solution is given by the Onsager equation:

$$\lambda = \lambda_0 - (a + b\lambda_0) c^{1/2}$$

- λ = equivalent conductivity at concentration "c"
(the conductivity of a volume of solution containing an equivalent of electrolyte, when the electrodes are put at one cm distance and have a surface large enough to contain all the solution between).
- λ_0 = equivalent conductivity at $c=0$ (infinite dilution).
- a,b = constants (for H_2O , $a=60.2$, $b=0.229$)

Debye and Falkenhagen predicted in 1927, and Sack found in 1928 that, for alternating electric fields, if the period is equal or less than the relaxation time, given by:

$$T=10^{-10}/c$$

the equivalent conductivity approaches the maximum, that is the conductivity at infinite dilution.

At $c=0.001$ normal (molar for 1:1 electrolytes like LiOH), the relaxation time is 10^{-7} seconds.

So with frequencies

$$\nu > 1/(2\pi \cdot 10^{-7}) \text{ Hz}$$

that is

$$\nu > 1.6 \cdot 10^6 \text{ Hz}$$

there are important effects, that is the conductivity may double with respect to the DC conductivity. Approximately the same effects can be obtained with voltage pulses of equivalent frequency.

1.3 Wien effect

Wien (1927) found that the application of strong electric fields increases appreciably the conductivity. Detectable effects can be obtained for ionic speeds that allow the ion to cover more than once the diameter of the ionic atmosphere ($3 \cdot 10^{-8}$ cm) in the relaxation time.

The speed of ionic migration is of the order of $5 \cdot 10^{-4}$ cm/s per unit of electric field [V/cm].

The Wien effect becomes therefore detectable for fields of about 600 V/cm.

1.4 Self-biased pulsed electrolysis

In our particular case, because the final purpose of the electromigration is to overload the palladium electrode with deuterium, both effects result in a better exploitation of the applied voltage.

Nevertheless we anticipate and stress that the clue of the method resides in the employment of a very high voltage with global low average power. Which means the development of very high electrode overvoltages without damaging the electrode to be overloaded. This has been made possible by using high voltage pulses of about 100 ns of rise time at repetition rate of the order of 10^4 Hz and, to maintain into the Pd electrode the deuterium loaded during the high voltage pulses, the introduction of a proper rectifying diode between the

pulser and the palladium electrode that brings the electrolysis yield factor to 95% of that of electrolysis in DC.

2. Experimental conditions selection criteria

In order to obtain a high voltage drop it is obviously necessary to apply a large current and to use very thin and long wires (to increase the resistance).

At the same time we have to reach high values of D/Pd ratio.

We have the following types of problems:

- an intrinsic *lower bound* of the diameter of the wire, due to the embrittlement phenomena occurring in D or H loading.
- increasing the *voltage* we also increase the *current* producing a higher heat dissipation along the wire (*Joule effect*).

High temperature causes two effects

a) c/c_0 decreasing due to Z^* decreasing

b) D/Pd decreasing, according to usual PCT curves, at least in the exothermic region of the PdD system.

We solved both problems using current pulses with HF harmonic as large as possible.

In this way the effective conductive portion of the wire decreases because of the skin effect; it is then possible to use thicker wires, thus reducing the technological drawbacks of embrittlement and cracking of palladium.

By reducing the skin depth we also reduce the current necessary to obtain high voltage drop.

The skin depth depends on the fundamental harmonic frequency of Fourier analysis and there is a relationship between this frequency and the pulse rise time, thus we have to optimize the rise time (within the technological constraints).

- We reach the compromise of a rise time of 100 ns.

In order to reduce the Joule effect we reduce the pulse duration and the repetition rate in such a way that the mean value of the current density is quite low.

In order to reach high values of D/Pd ratio the pulses must have the following features:

- the pulse duration must be longer than the minimal time to obtain electrolysis. This is only 300 ns in our experimental conditions for the combined effects:

- Debye-Falkenhagen and Wien effect.

We found that Faradaic electrolytic efficiency is about 5% due to this effect only. This specific test was performed short circuiting the diode UFPD in Fig. 2a.

- self-polarization of cell due to a diode (Fig 2a, UFPD) used as a decoupler, between power pulser and cathode.

We made some experiments to verify the efficiency of our pulsed loading technique. We saw that the electrolysis efficiency raised to a value as large as 95% using this unconventional experimental set up [4].

- even if the time duty cycle of the pulse must be low (in order to minimize the mean input power) it must be high enough in order to avoid the deloading between pulses. We consider that during the electrolysis some impurities (mainly nickel from the anode and lithium) coat the cathode causing the desorption which is slower than the absorption. The effective pulse duration in our experiment is $750+1500$ ns, while the dead time between two pulses is about $99 \mu\text{s}$ at 10 kHz of repetition rate.

3. The experimental Set-Up

We built an apparatus whose configuration has been optimized in order to discriminate the contribution on deuterium concentration due to electrolysis from the electromigration contribution.

The electrolytic cell is made of commercial glass, the solution is LiOD-D₂O. A palladium wire (we tested different lengths, larger than 10 cm, and different diameters, less than 500 μm) is immersed in the electrolytic solution.

The electrolysis occurs between a part of the wire (effective length about 6 cm) and a coaxial nickel cylinder (internal diameter 12 mm) used as anode. This side of the wire is used mainly as a source of deuterium or hydrogen while the other long side (the sink), is used mainly to investigate the electromigration effect. Obviously, the most cathodic point of the system is the end of the long wire (named V₂), as shown in Fig. 1, where the voltage (negative μs pulses) is sent to the palladium wire. The experimental apparatus is described in Fig. 2.a, 2.b, 2.c, 2.d.

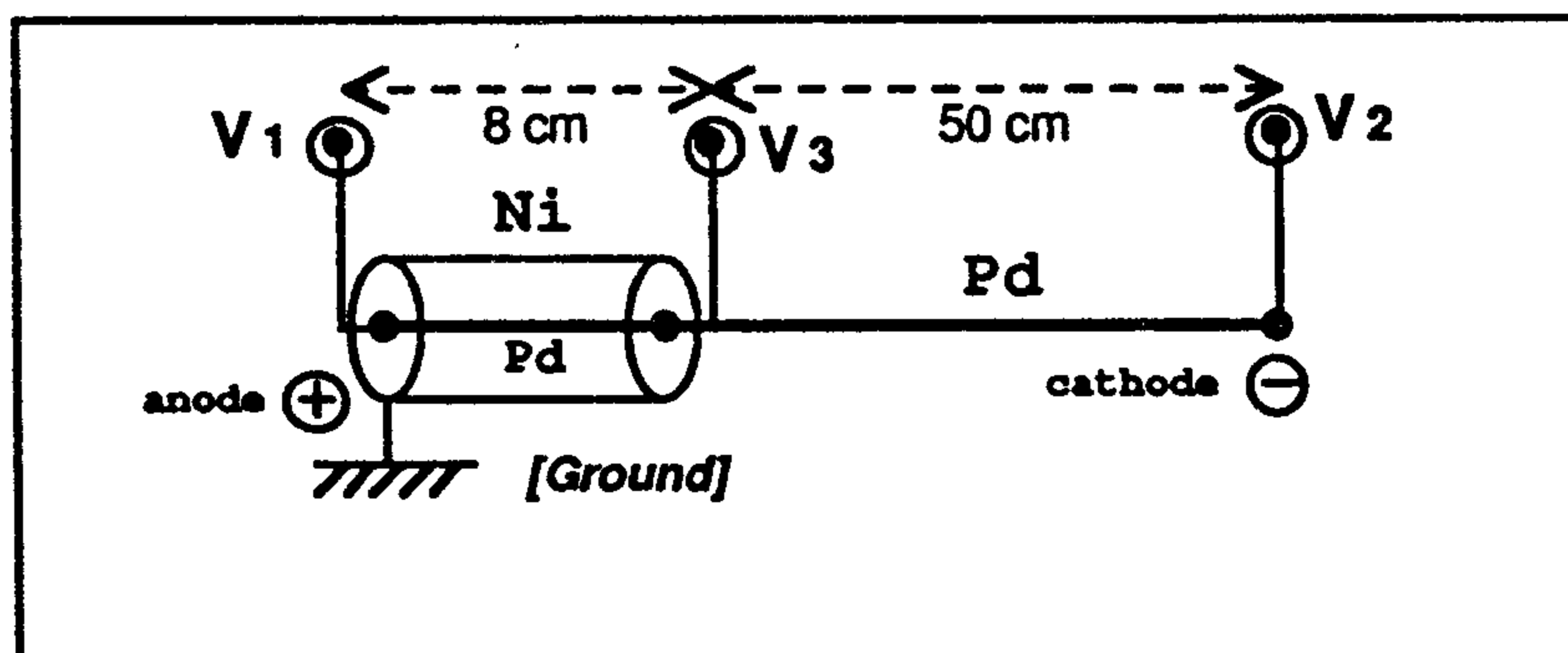

Fig. 1
Electrodes principle scheme

The system, from the point of view of calorimetry, can be described as a quasi-isoperibolic calorimeter where the heat exchanger is the environment (room temperature kept at constant temperature of $20 \pm 2^\circ\text{C}$) and the calibration heater is cyclically (every 6 hours) powered (1 Watt) in order to continuously calibrate the system and calculate the so called "cell exchange constant" ($^\circ\text{C}/\text{W}$) at various temperatures and overall experimental conditions (aging of solution due to glass dissolution by LiOD, different bubbling due to different electrolytic currents and so on).

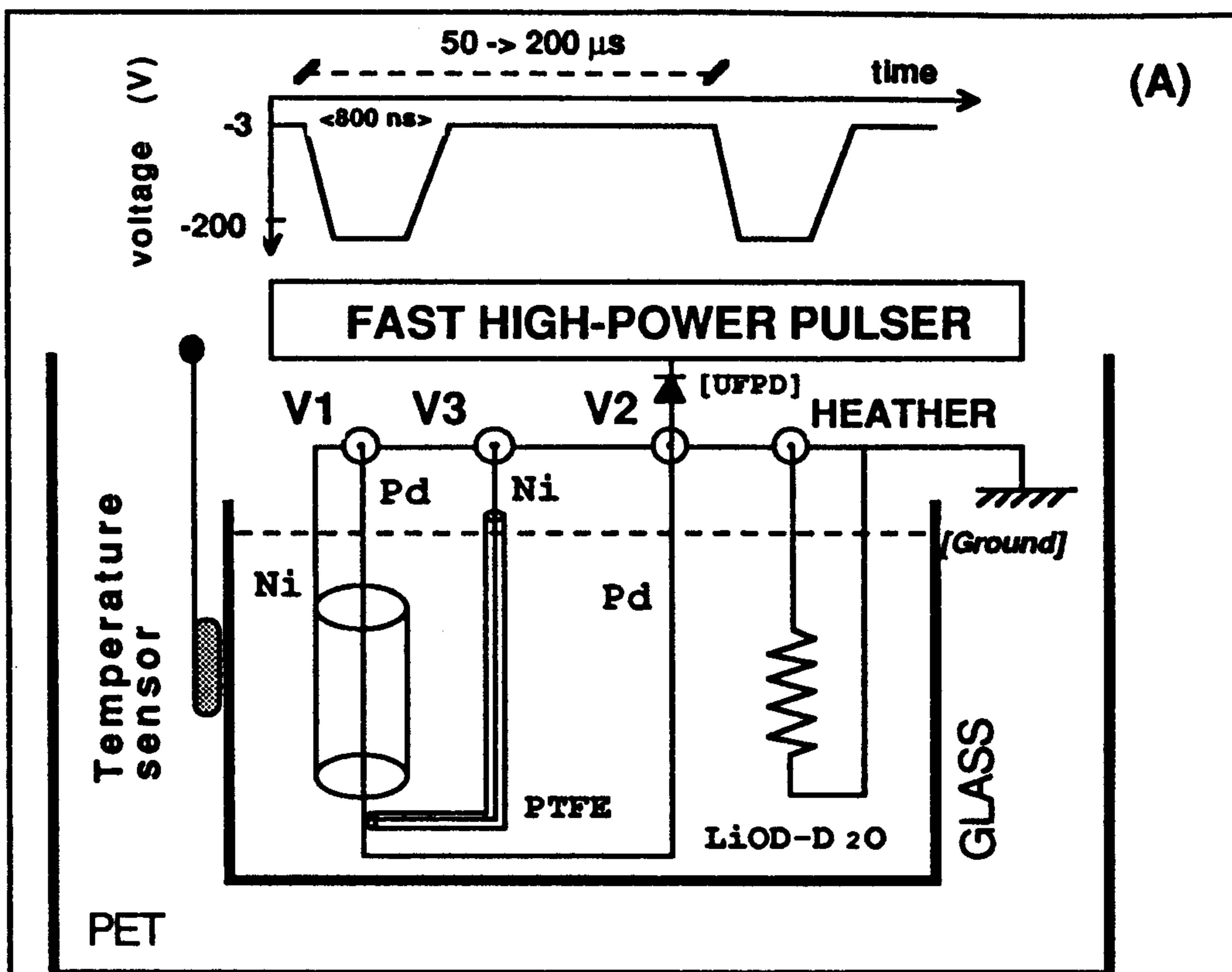

Fig. 2.a) Apparatus set-up.

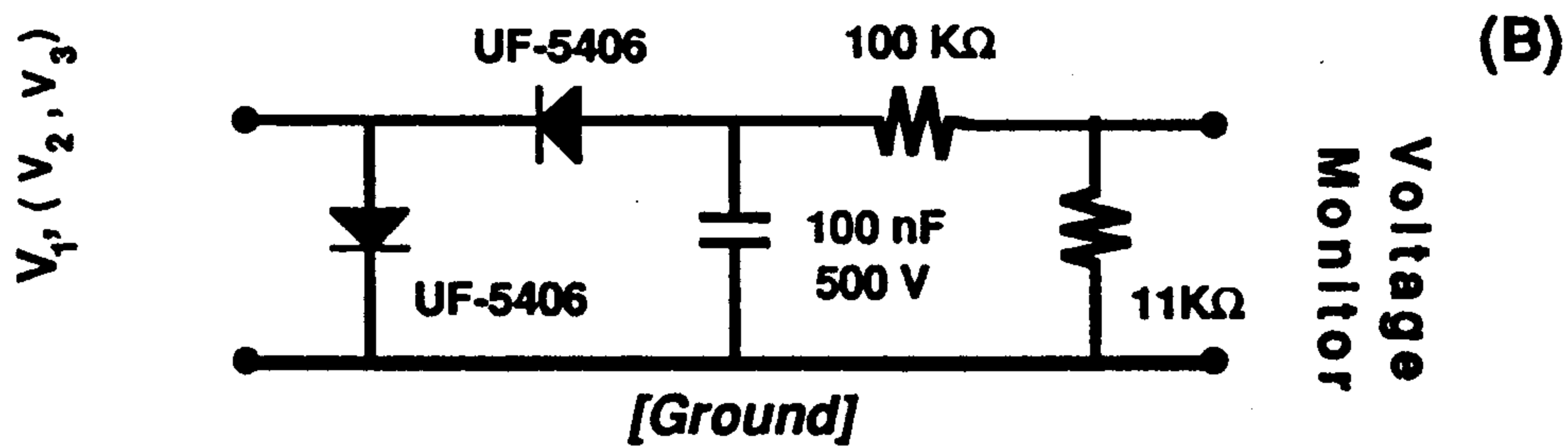

Fig. 2.b) Peak detector circuit.

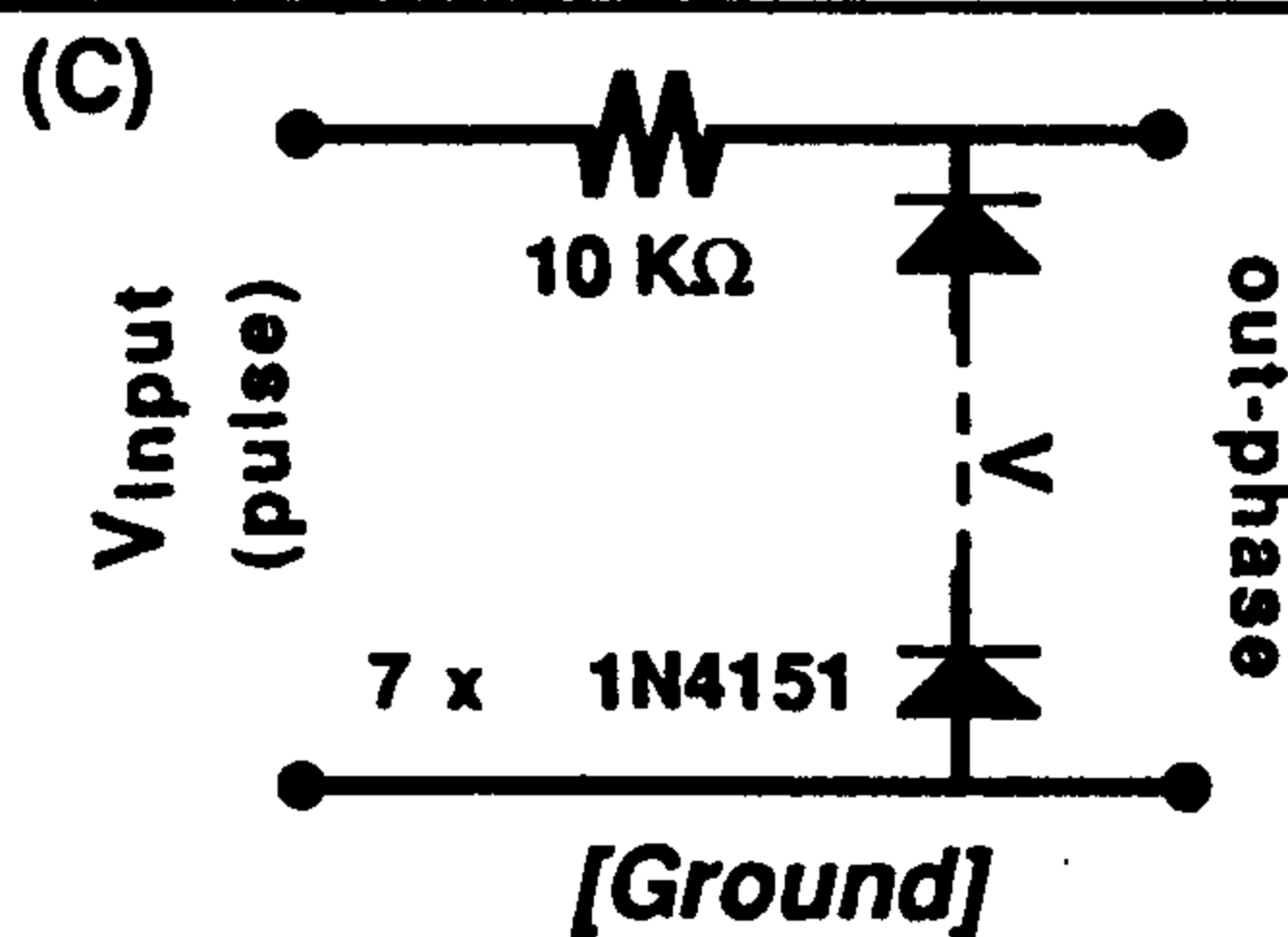

Fig. 2.c) V out- ϕ circuit.

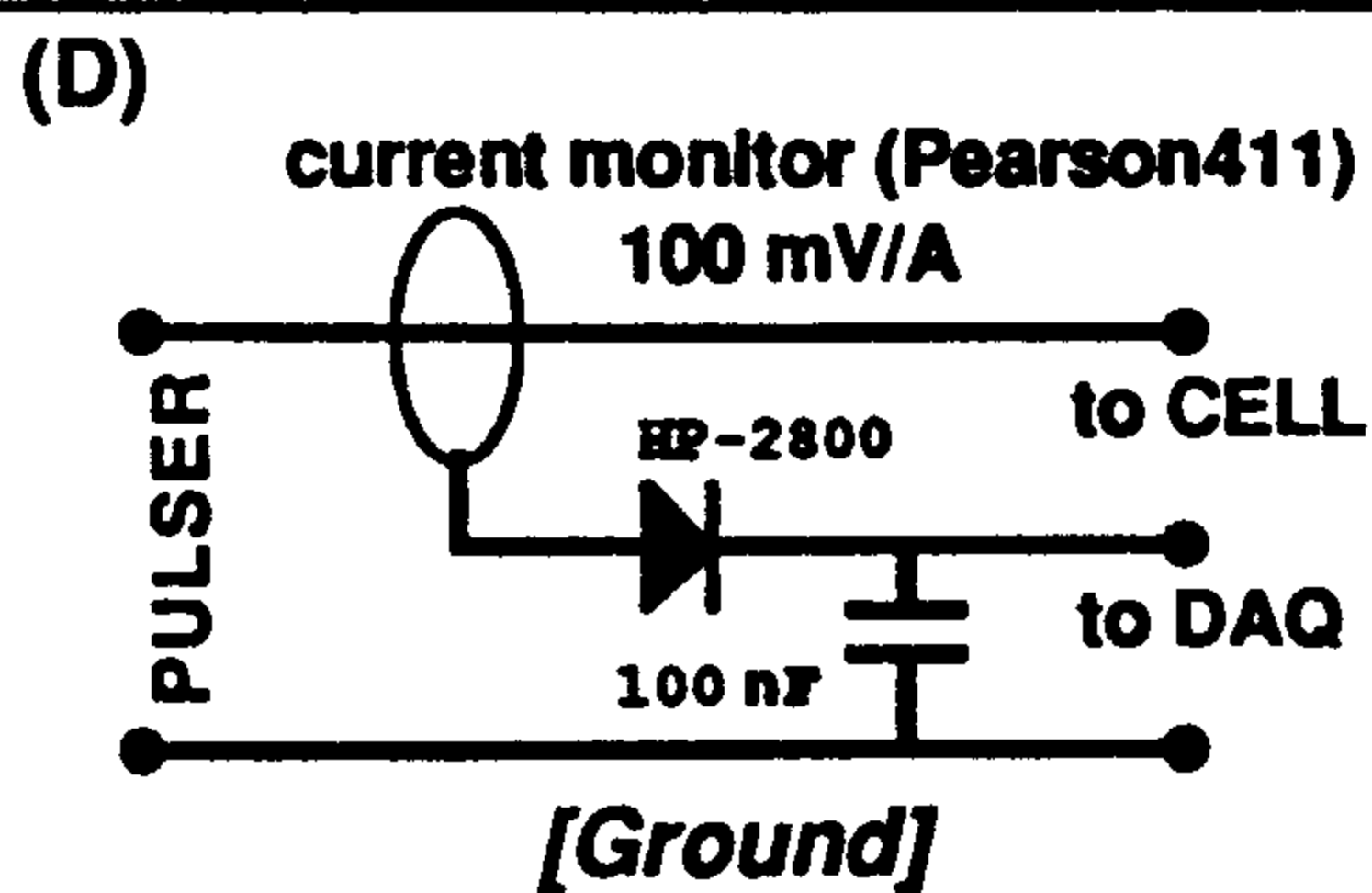

Fig. 2.d) Current circuit.

The thermometer, located on the external cell wall, between the palladium wire and the electrolytic heater, is an integrated circuit silicon thermometer (AD590) with metallic case connected to ground (in order to minimize pick-up noise) and operated at quite large ratio of output voltage/input temperature (i.e. $10\text{mV}/^\circ\text{C}$) in order to reduce systematic errors that can arise from unpredicted large variations of the "reference ground" at the input of the computer controlled multiplexed-multimeters (HP3457A).

The cell is powered μs duration, KHz repetition rate, high power regime, following, with further improvements, the procedure developed by us since march 1993[5],[6],[7]. The rise time of the input pulse is typically 100 ns, the fall time varies between 150 ns and 1500 ns (depending on electrolyte concentration, i.e. longer at lower concentration), the duration of the flat region is typically 500 ns.

The applied peak voltage ($V_2 - V_{\text{GND}}$) varied between -80 V and -200 V. The voltage peak values at V_1 , V_2 , V_3 points (see Fig. 2a) are acquired through an ultra-fast passive peak detector (Fig. 2b).

The so called cathode-anode voltage ($V_{\text{o_pha}}$ = out of phase voltage), when no power is applied (related to the well known overpotential) is read through a fast and simple circuit [Fig. 2.c]. Obviously, this kind of simple circuitry gives information useful for comparison only at a given fixed operating frequency of the system (i.e., it is not correct to compare different values of $V_{\text{o_pha}}$ at different operating frequencies).

The peak current injected to the wire is read through a fast rise time (20 ns) high peak current capability (5,000A) current monitor (Fig. 2d) and transformed to a dc level through a fast, low-drop, low leakage, shottky diode (HP2800) and ceramic capacitor.

3.1 Typical operating conditions

The experiments were performed under the following operating conditions:

- Peak current density along the wire : $50,000 + 300,000 \text{ A/cm}^2$ (1).
Peak current density on the side of the electrolyte: $10,000 + 100,000 \text{ mA/cm}^2$
For comparison, the typical values of mean current density in Cold Fusion experiments ranges between 64 and $1,000 \text{ mA/cm}^2$.
- Rise time of the pulse is in the range of 100-250 ns. When the peak current is increased, also the rise time increases; however with currents up to 25 A we still have 100 ns of rise time.
- The pulse duration is 500 ns.
- The fall time is between 100 and 1,000 ns (increases decreasing LiOD concentration).
- The pulse repetition rate is between 5,000 and 20,000 Hz.
- The electrolyte concentration has been varied between 0.01 and 0.3 N LiOD
- The diameter of the Pd wires studied were: 100, 250, 300, 500 μm
- The total wire lengths were : 20, 50, 100, 200 cm.
- The anode was made of Ni. We plan to study in the near future also Pt, Au, Pd.

(1) Some tests were performed with a current density as large as $500,000 \text{ A/cm}^2$. These values of current density are not too far from typical regions of pinch effect in hot fusion studies, so we can expect even the emission of soft X-rays. We are planning to build an experimental set-up to clarify this point.

4. Main results

The main results were obtained with a wire of 100 μm of diameter and 50 cm length , effective peak current density 100,000 A/cm^2 and repetition rate of 10,000 Hz.

We estimated the D/Pd ratio from measurements of wire resistance in each of the two sides of the wire : in the following we name ACTIVE the side coaxial to the anode and COEHN the other one (Fig. 1, side V2-V3). The resistance measurements were done in two ways: in situ and also by AC bridge measurements (HP 4262 LCR METER operating at 120 Hz, 1kHz, 10 kHz) just after switching off the system.

At the same time we evaluate the excess heat production by the calibration method quoted in the previous section.

The resistance ratio reaches its maximum value in the ACTIVE side after 250 seconds from the beginning of the electrolysis. After this, the R/R₀ ratio decreases until it reaches a value corresponding to an average D/Pd ratio of about 1.0.

About 200 seconds after this minimum has been reached the resistances ratio "jumps" abruptly and comes back to a value corresponding to D/Pd ratio of about 0.8 (Fig. 3).

This back "phase" transition has a cyclic behavior and it is observed only when the applied potential is higher than a threshold value (about 130 V with our configuration).

We want to note that, although on the side of the wire that undergoes only electromigration effect (COEHN) there should be, *de principio* , cathodic and anodic (with nominal no loading) regions, *de facto* we have seen that the average loading was larger than 0.8 (Fig. 5).

This observation leads us to conclude that the electromigration effect is even stronger than the anodic effect or, speculatively, that a new effect exists, due to the large voltage drop, that is able to keep the deuterium inside the Pd wire (as suggested by G.Preparata [8])

The excess heat seems to have a cyclic behavior and starts (at low intensity) only 250 sec after the beginning of the electrolysis and increases along the time following the behavior of bulk loading (Fig. 5).

The excess energy obtained in the previously described experiment was about 50% (with a 5% accuracy) of the input power, i.e. typically about 5 W of excess heat. However in other experimental conditions we have obtained heat excess up to 150%, even though in unstable conditions.

The results show that the increase of the observed excess heat is related to :

- Decrease of the wire diameter
- Increase of the wire length
- Decrease of the pulser rise time (i.e., larger skin effect)
- Decrease of the LiOD concentrations up to a value of about 0.001 N (although quite unstable at low concentration); reproducible results have been obtained between 0.01 and 0.1 N.
- Increase of the repetition rate of pulses.
- The presence of some proper impurities (Ni, Pb, borosilicate) which cover the surface of Pd; this effect has to be fully studied.
- Increase of the mechanical stresses of the wire (cold working), mainly because this increases the resistivity

Almost all the previous experimental effects listed show that the voltage drop along the wire, together with the "overvoltage " value, could be the most important or even a *key parameter*.

Moreover we often have observed that even the application of a calibration power level at the heater (1 W) gives an increase of overall power gain. This effect can be explained, and it is a further proof, that the excess heat happens when the D/Pd system is in the endothermic region, that is when D/Pd is quite larger than 0.8.

We also notify that in some experiments we measured a R/Ro value less than 1. This can be an evidence of the possible existence of a superconducting state due to the extremely large density of the deuterium inside the palladium lattice, as suggested by prof. J.P. Vigier (Paris University).

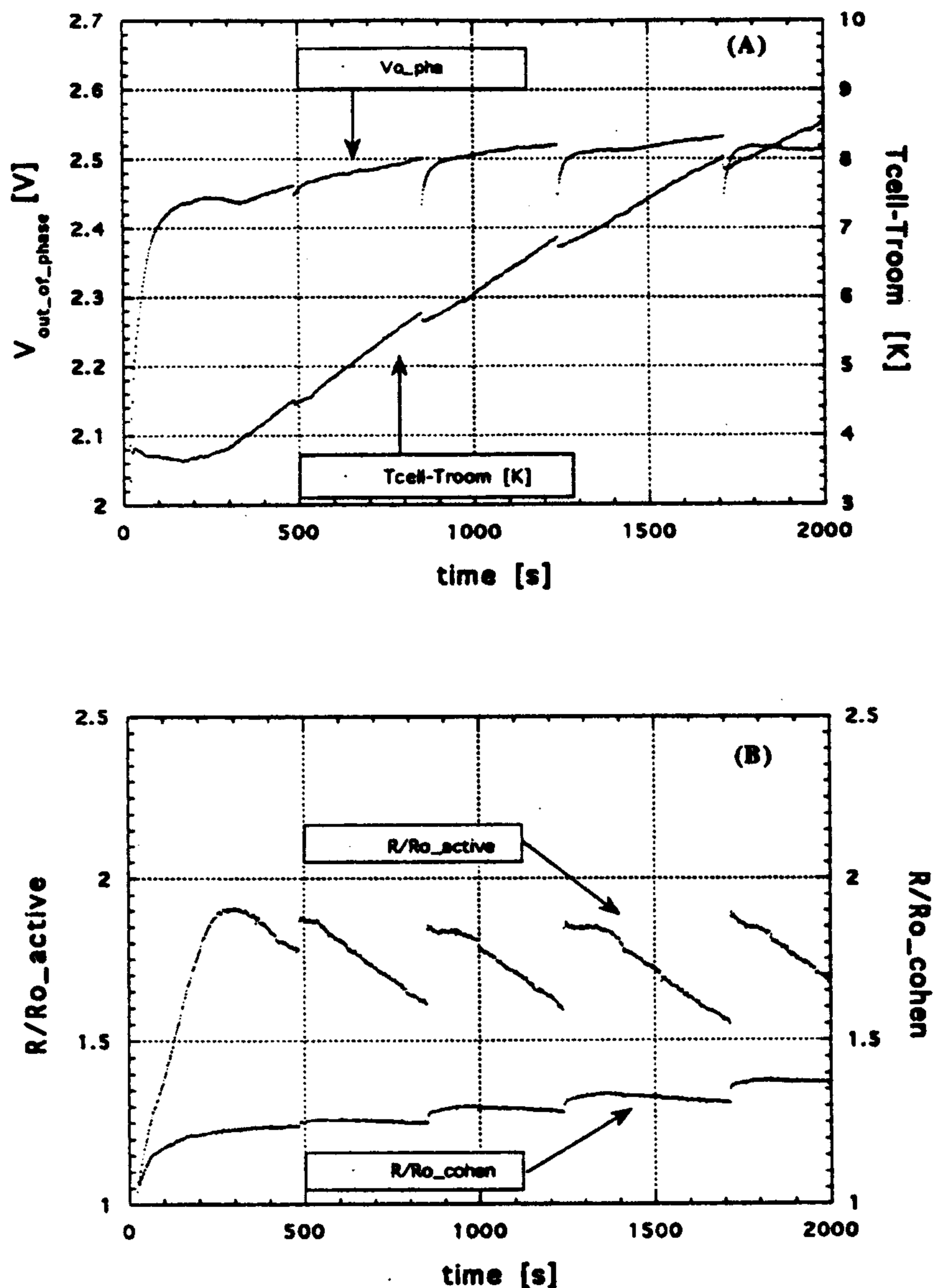

Fig 3

- (a) Trend of Voltage out of phase and trend of the difference between cell and room temperature during the first 2000 seconds.
- (b) Resistance ratio of the ACTIVE and the COEHN side of the wire during the first 2000 seconds.

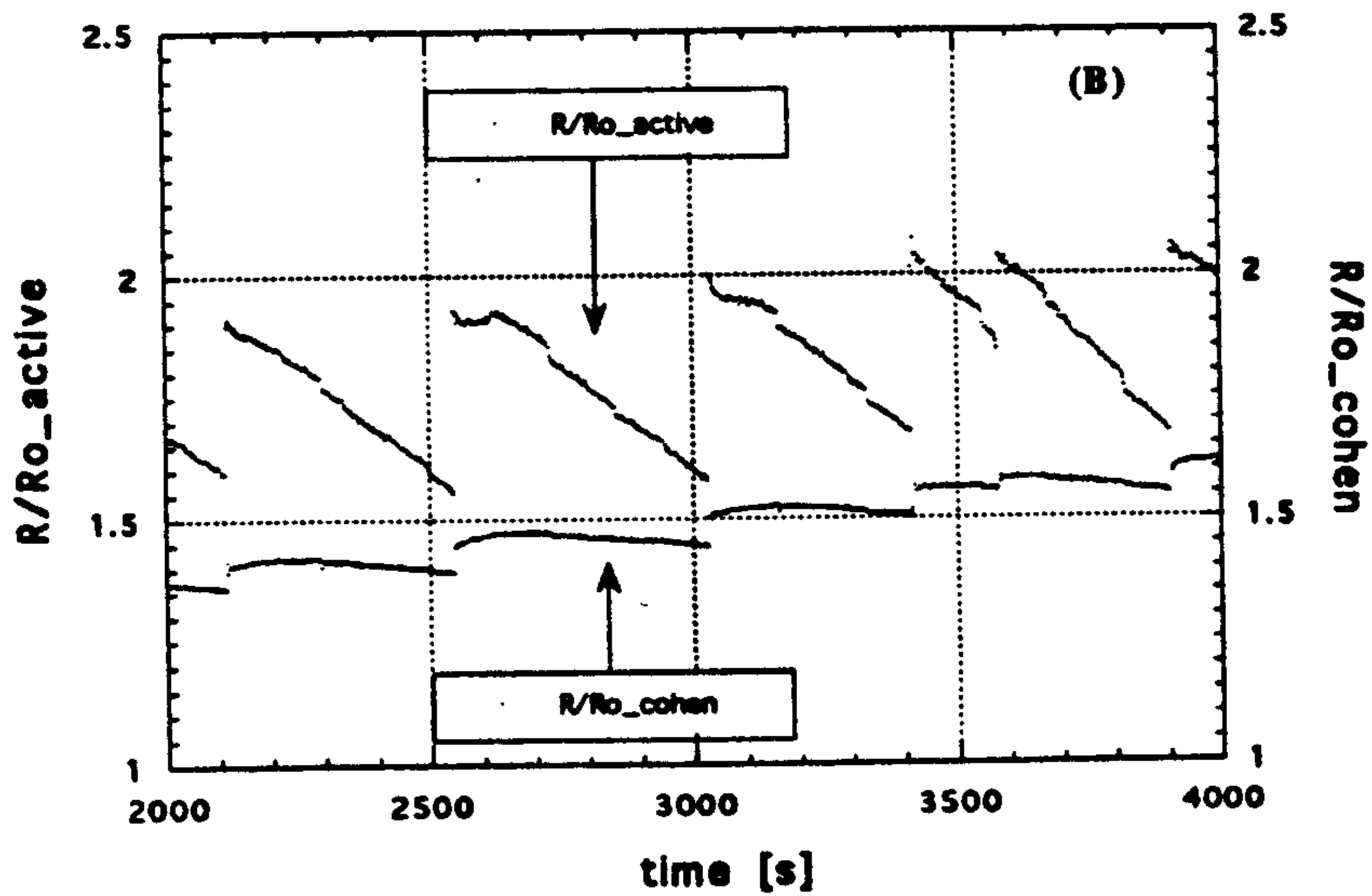
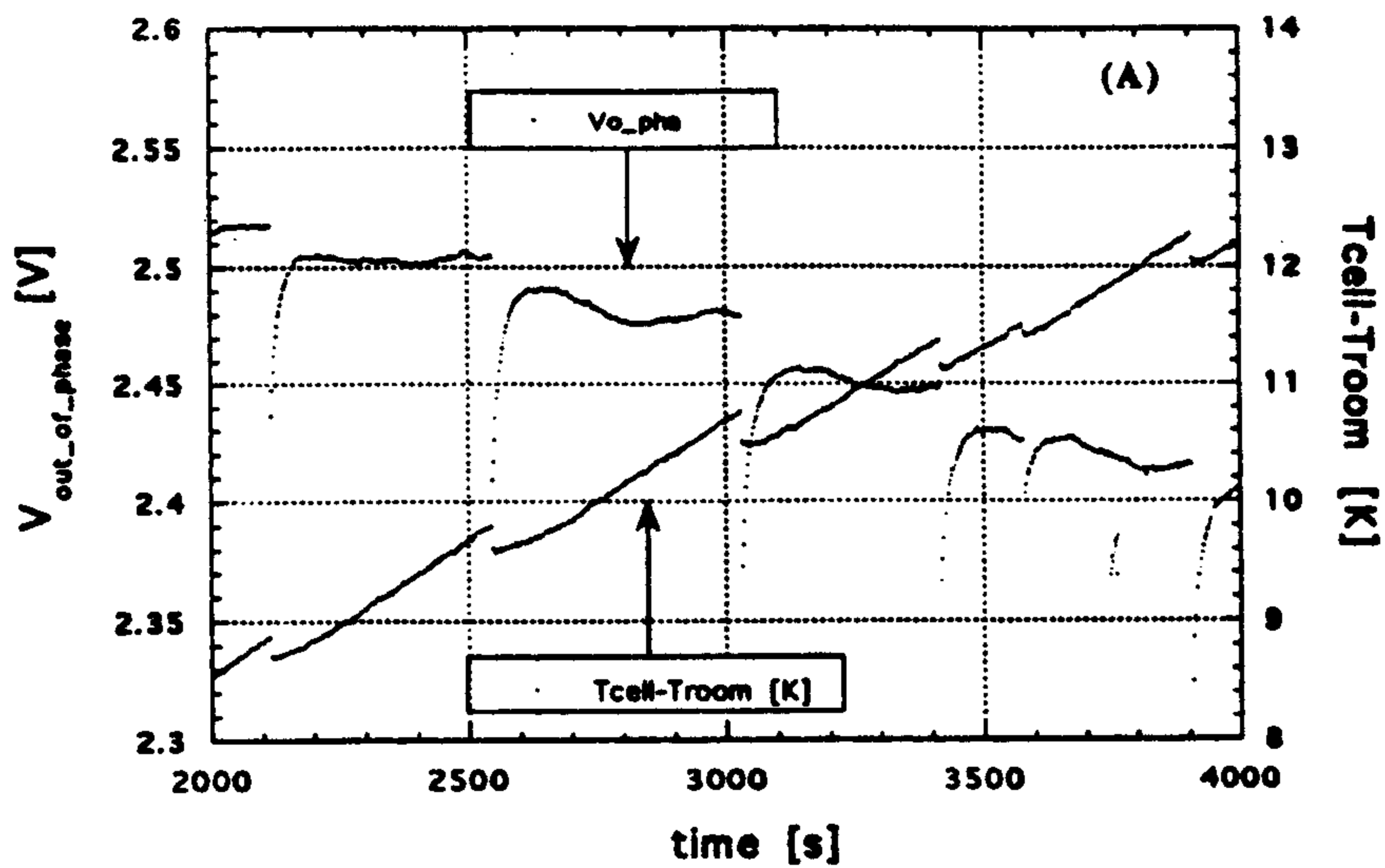

Fig. 4:

- (a) Trend of Voltage out of phase and trend of the difference between cell and room temperature during the time between 2000 and 4000 seconds.
- (b) Resistance ratio of the ACTIVE and the COEHN side of the wire during the time between 2000 and 4000 seconds.

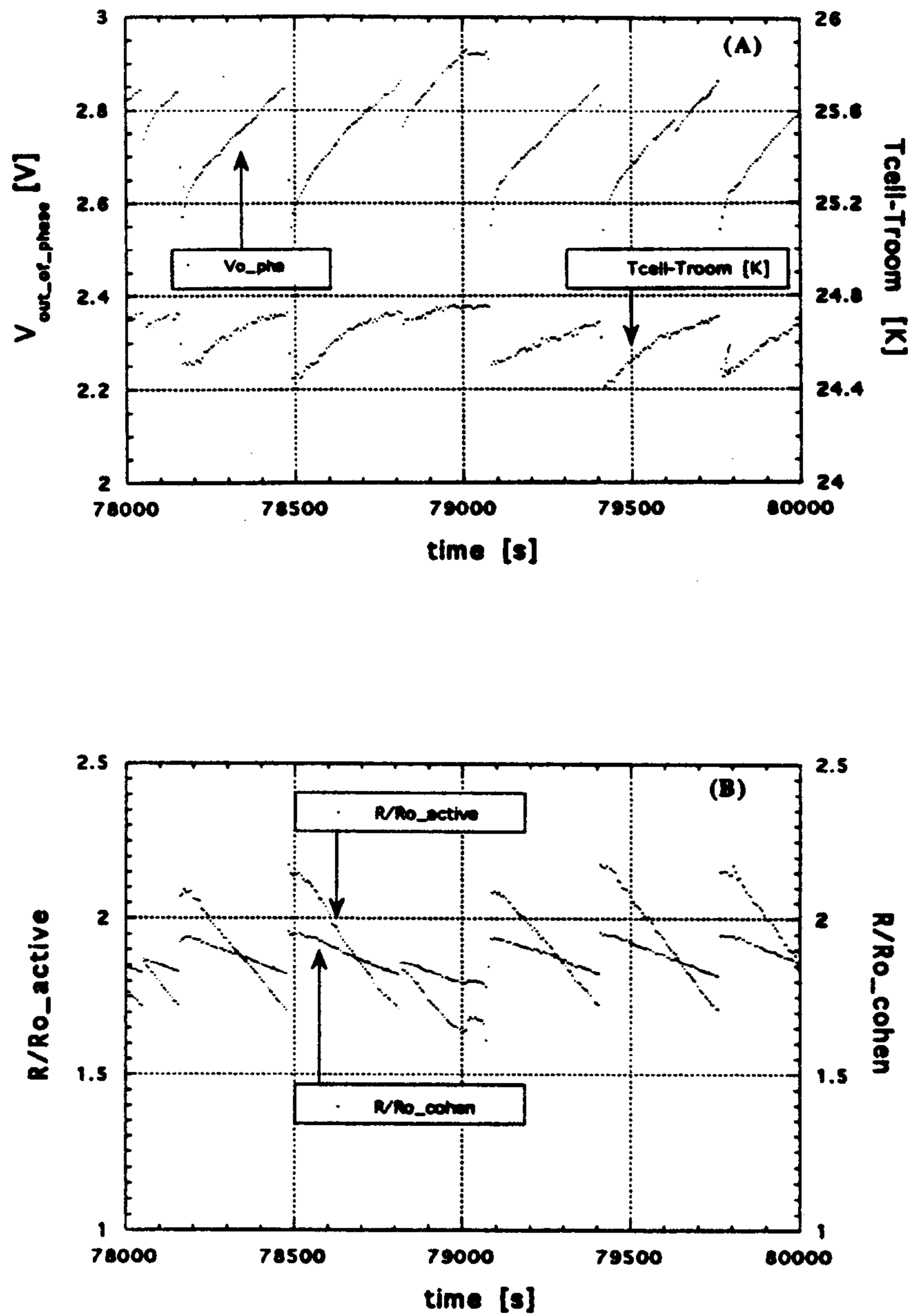

Fig. 5:

- (a) Trend of Voltage out of phase and trend of the difference between cell and room temperature during the time between 78000 and 80000 seconds.
- (b) Resistance ratio of the ACTIVE and the COEHN side of the wire during the time between 78000 and 80000 seconds.

Conclusion

We have observed that is possible to load above 0.8 almost any kind of palladium wire, once provided that some "intrinsically difficult" requirements are full-filled in a reproducible way and, overall, with a very short "waiting" time (only 200 s in some experiments).

About excess heat, if we accept that the procedure of self calibration is correct [9] in the framework of isoperibolic calorimetry, we observed that it starts when the D/PD ratio is larger than about 1 and, at least in our experimental setup, it has a cyclic behavior. We think that just electromigration is not enough to explain all the experimental phenomena we found, and that a new theoretical approach is necessary to explain our results [9].

Acknowledgments

We would like to thank prof. M.Okamoto (TIT, Tokio) and K. Matsui (IAE, Tokio) for very useful discussion, criticism and comments. Prof. J.P.Vigier (Paris, France) gave us useful comments.

The palladium wires were kindly provided from IMRA Material (Japan), Tanaka K.K. (Japan) and ORIM S.r.l. (Italy).

Dr. F.Ferrarotto (INFN, Rome), gave us strong suggestions about the behavior of pulsed electrolysis since march 1993.

References

- [1] A. Coehn, Z. Elektrochem, 35, 676, (1929)
- [2] Hydrogen in metals II, Topics in applied physics, vol 29 , Springer and Verlag, ed. G. Alefeld and J. Volkl, 277, (1978)
- [3] Giuliano Preparata, private communications, November,(1994)
- [4] F. Celani, M. Boutet, D. Di Gioacchino et al., "First results about hydrogen loading by means of pulsed electrolysis of YBCO pellets", Physics letters A 189, 397, (1994)
- [5] F. Celani, A. Spallone, P. Tripodi et al.
Conference proceedings ICCF3, Vol.1, pag.22_1+ 22_14, (1994)
- [6] F. Celani, A. Spallone, P. Tripodi et al.
Fusion Technology, Vol. 26, pag 127-137, (1994)
- [7] F. Celani, A. Spallone, P. Tripodi et al. "Reproducible D/Pd ratio over 1 and excess heat correlation by μ s pulse high current electrolysis." Publishing on Fusion Technology, (summer 1995)
- [8] G. Preparata (private communications, December 1994)
- [9] G. Preparata, M. Scorletti, M. Verpelli, "Isoperibolic calorimetry on modified Fleischmann-Pons cells", Preprint of Physics Department, University of Milan, MITH 95/4 (1995)