



Laboratori Nazionali di Frascati

LNF-94/006 (P)
18 Gennaio 1994

F.Celani, A.Spallone, P.Tripodi, A.Nuvoli, A.Petrocchi, D.Di Gioacchino, M.Boutet,
P.Marini, V.Di Stefano:

**HIGH POWER μ s PULSED ELECTROLYSIS FOR LARGE
DEUTERIUM LOADING ON Pd PLATES**

PACS.: 25.45

Invited Talk
ICCF 4
December 6-9 (1993), Maui - Hawaii (USA)

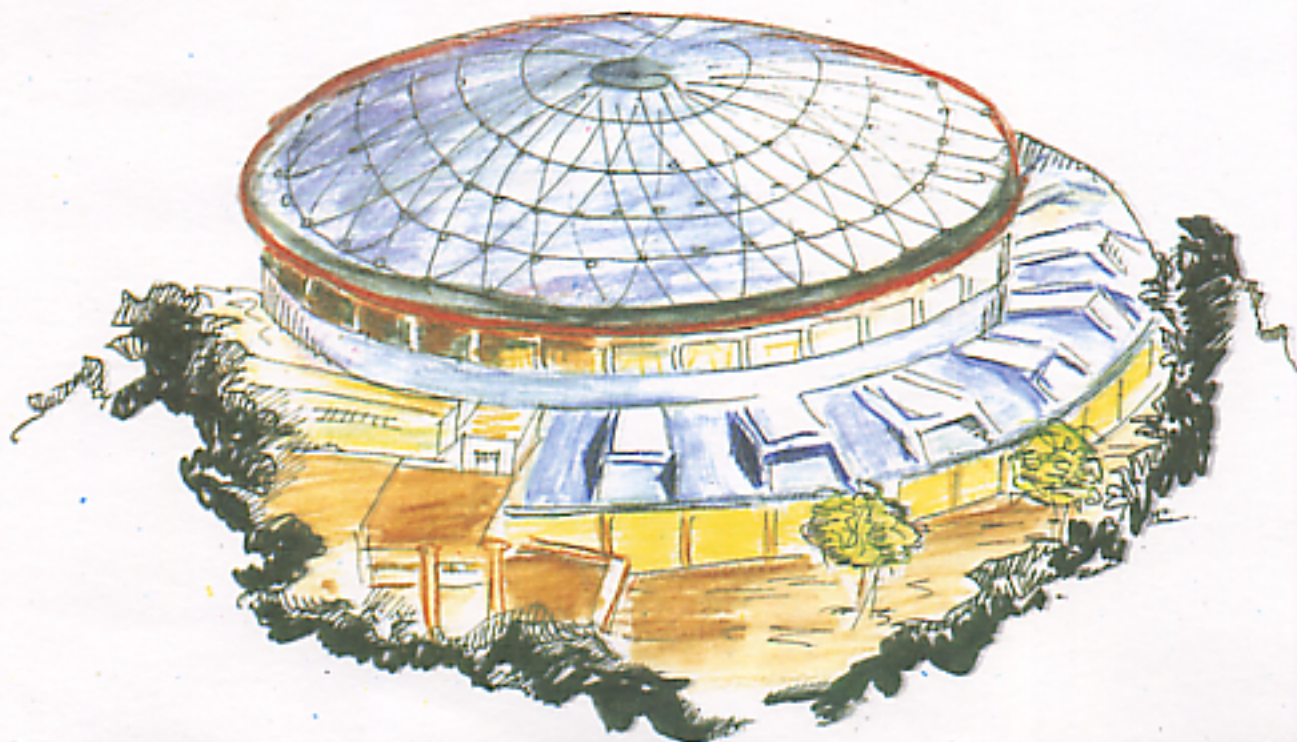

LNF-90/006 (P)
18 Gennaio 1994

**HIGH POWER μ s PULSED ELECTROLYSIS FOR LARGE DEUTERIUM
LOADING ON Pd PLATES**

F.Celani, A.Spallone, P.Tripodi(*) , A.Nuvoli, A.Petrocchi, D.Di Gioacchino, M.Boutet
INFN, Laboratori Nazionali di Frascati, via E.Fermi 40, I-00044 Frascati (Italy)

P.Marini, V.Di Stefano
SKITEK, IRI, Pomezia (Italy)

ABSTRACT

An high peak current (up to 100 A) and a very short pulse (1 μ s) generator was used to perform electrolysis in D₂O-LiOD solution using a Pd sheet as a cathode and a Pt net as an anode. This high power pulse (up to 50 KW) can be rated up to 20 KHz.

Very high D/Pd values (up to about 1:1) has been reached with any cold-worked Pd sheets used. A very hard sheet (about 300 Hv) has generated an excess heat of the order of 15% for a long time (some weeks).

Some considerations about the metallurgy of electrodes are performed and an effort is made to correlate the excess heat with metallurgical parameters, over-voltage and surface resistance.

1.- THE EXPERIMENTAL SET-UP

The adopted electrolytical system was already described in the previous ICCF3 Conference at Nagoya (Japan)⁽¹⁾ and consists of a flow calorimeter composed by a cylindric polyethylene vessel containing a double turned copper coil used as a cooler. The ordinary water, passing through the coil, cools the solution. Seven temperature sensors are properly located in order to measure the produced heat and to cross-check the calorimeter operation.

(*) INFN fellow.

In respect to the Conference at Nagoya, we improved the system modifying the Pt sample-holder net at the anode (fig. 1). The Pt wire was turned around in an opportune way in order to smooth the not-uniform electric field at the edges of the sheet. In this way we reduced the effect of the Deuterium discharge at the edges due to the strong electric field gradients. In this figure it is shown the reference electrode, consisting in a Pt wire, located in front of the Pd plate (2mm distant); the wired Pt anode net is 1 cm far from the cathode and the electrolytic solution is LiOD 0.3 M/l D₂O.

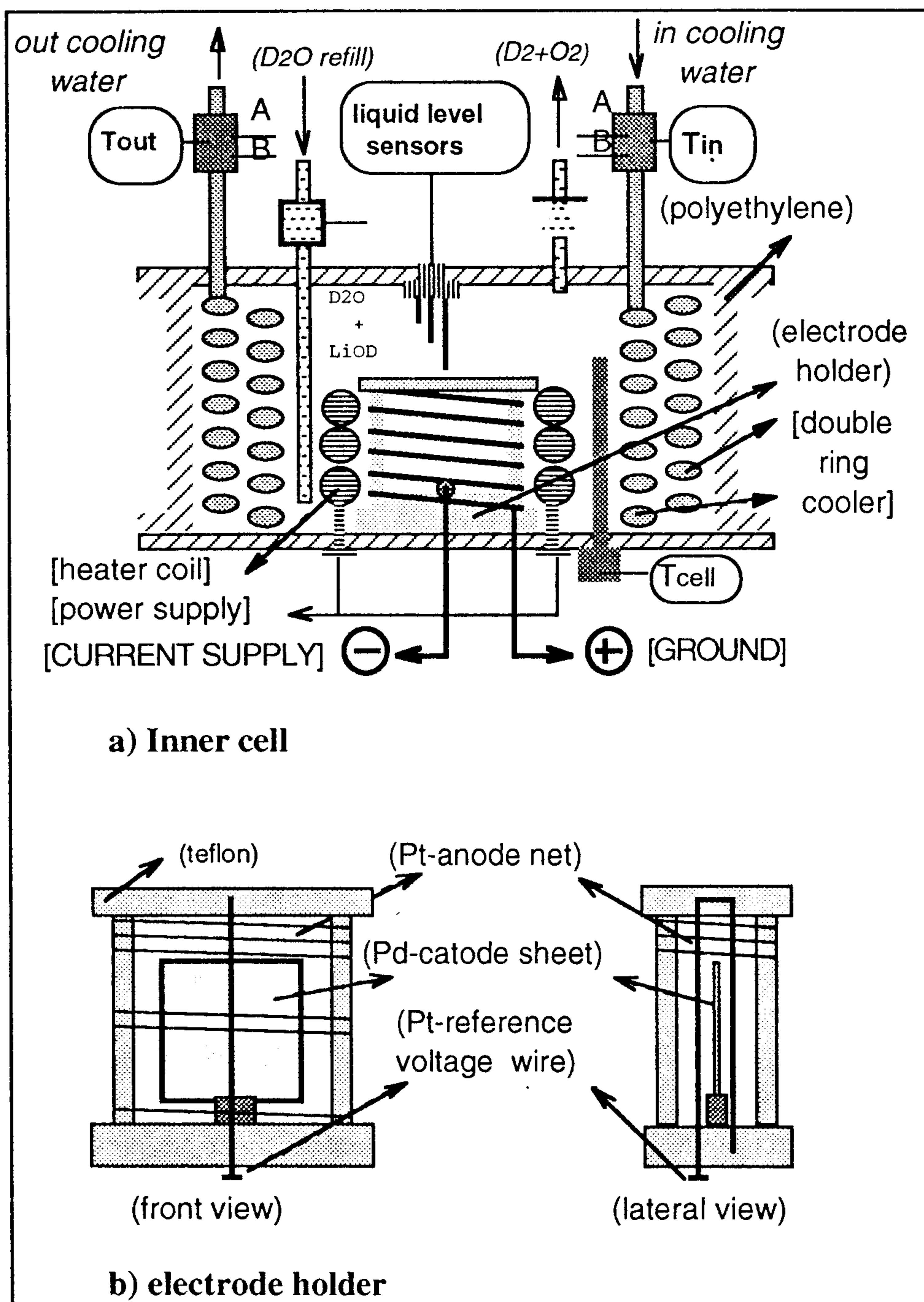

FIG. 1 – Inner cell design and electrode holder.

A significative improvement was performed to the gas system. Two electrovalves were inserted (fig. 2): the first one on the top of the cell and the second one after an additional volume. Depending on which electrovalve is closed or opened, it is possible to have two well-defined volumes (a smaller volume of about 100 cc and a larger one of about 1000 cc). We determine these volumes measuring the gas pressure developed during the electrolysis and knowing the electric charge flowed through the electrodes (using the gas law and the Faraday equation). In this way we calculate the quantity of moles of D_2 absorbed by the Pd, measuring the missing pressure. We usually operate leaving close the input electrovalve until the gas pressure reaches a definite value (50 mbar), further on we open this valve allowing to the gas to flow away. A proper circuitry was made to control this cyclic operation. The two volumes are chosen according to the value "low" (<200 mA) or "high" of the mean electrolytic current, in order to reduce the relative error in the measurement of the absorbed D_2 moles.

A specific circuitry was made to generate a very sharp high current pulse as shown in figure 3. The in-phase circuit measures the flowing electric charge and the energy absorbed from the cell in a single pulse. The out-of-phase circuit measures the voltage of the cathode and the voltage of the Pt floating electrode, which is put in the solution close to the cathode (2 mm). These voltages are properly used to determine the over-voltage parameter too. The out-of-phase voltage measurement is performed after a delay (30 μ s) from the end of the pulse. This enough long delay allows to avoid electric noise, during the measurement of low level signals (about 2 V), generated by the high level pulse (up to 150 V).

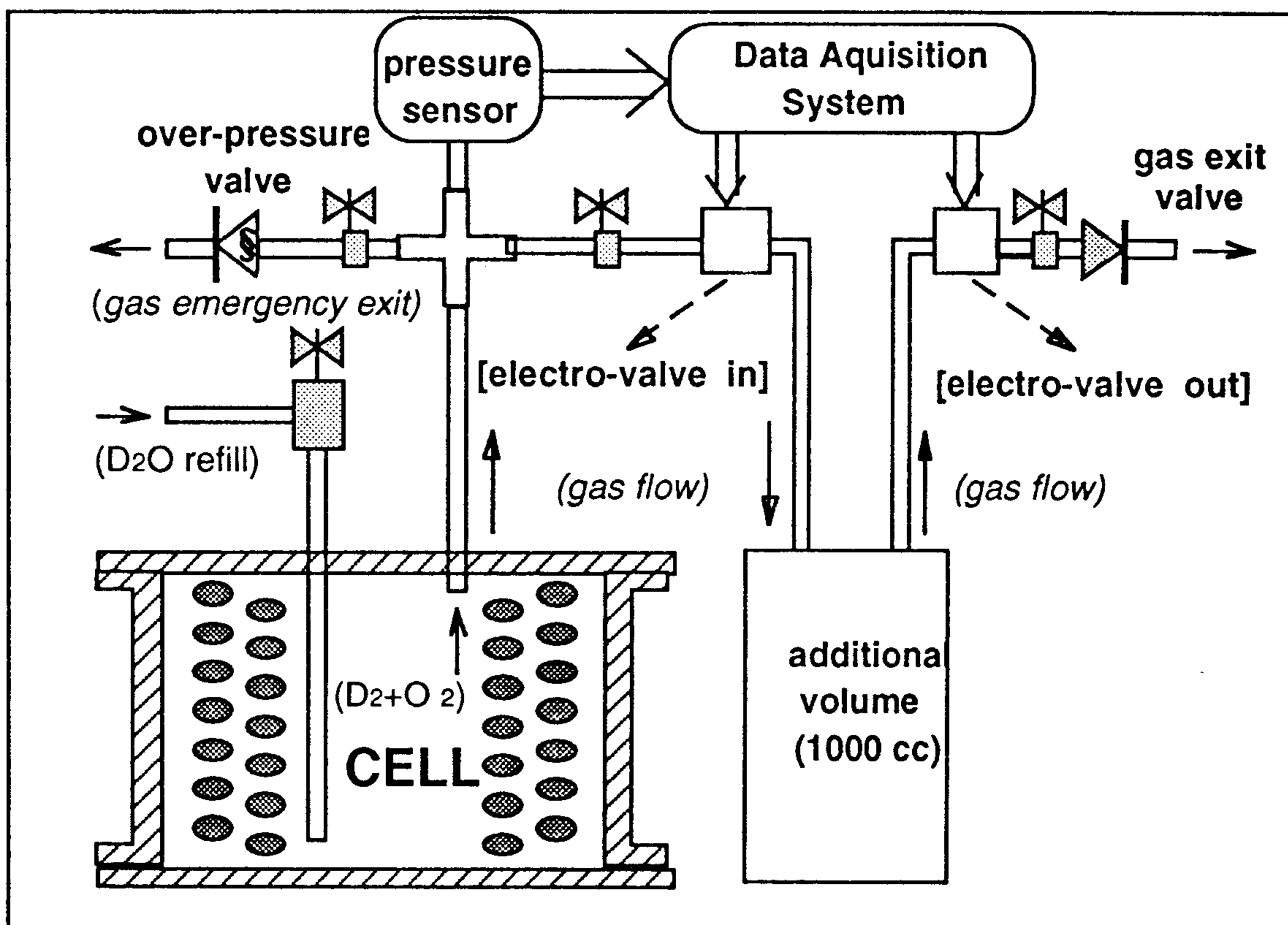

FIG. 2 – Outgoing cell gas system.

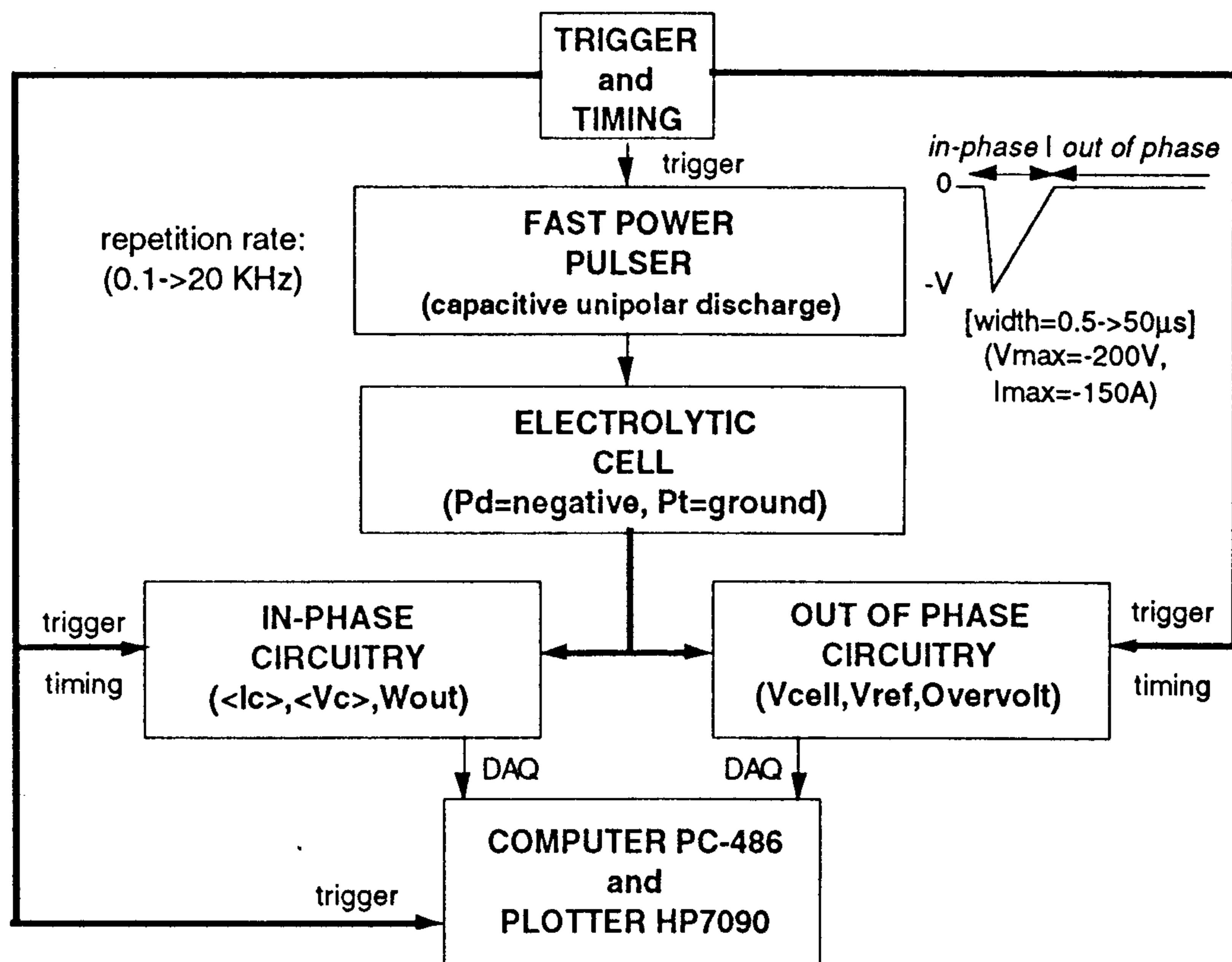

FIG. 3 – High power pulse circuitry: block scheme.

2. – THE DEUTERIUM ABSORPTION MEASUREMENTS

We performed some blank runs using an Au plate to test the functionality of the circuitry and to calibrate the input power reading module. We tested the gas collecting system and we measured the D_2 absorbed by the stuff present into the cell (solution, polyethylene, heater, teflon etc.). This D_2 absorption, occurring only during the first charging-up, slowly decreases in time (it disappears, in our case, after about 600 C of electrolytic charge) and the D/Au reaches a maximum value of 0.01. In the following calculations we took into account this small effect performing the opportune corrections to the data.

We tested three cold-worked Pd sheets (25x25x1 mm) named: T05, T18 (TANAKA K.K.) and I85 (IMRA MATERIAL). The TANAKA plates (very high hardness value: 300 Hv) were prepared with proper impurities (2780 ppm) enclosed during the melting preparation: the high hardness reached is due to the doping (under patent).

The following operating conditions have been used for the T05 plate: pulse peak current 16 A, pulse width 0.5 μs, pulse repetition rate 5 KHz. These conditions are equivalent to an electrolytical mean current of about 64 mA.

In figure 4.a it is shown the absorption rate (in Mole/s·cm²). It provides informations about the quantity of Deuterium flowing through the Pd-surface per time unit and surface unit. The absorption efficiency (defined as the ratio of the quantity of absorbed Deuterium to the

Deuterium developed during the electrolysis) reaches its maximum value in the α phase (about 71% as reported in tab. 1). The $\alpha+\beta$ phase is identified by the shoulder of the curve. The absorption rate decreases during the β phase, zeroing when the D/Pd concentration reaches its maximum value equal to 1:1 (fig. 4.b). The D/Pd concentration has been evaluated cumulating the absorbed Deuterium moles in the time.

In figure 4.c it is shown the over-voltage as a function of the charge. We define the over-voltage as the difference between the cathodic potential and the reference electrode previously described. All electric potentials are measured in respect to the Pt net electrode which is connected to the electric circuit ground. During the electrolysis the Deuterium gas, developed at the cathode, surrounds the reference electrode and we can assume it as equivalent to a R.H.E. (Reversible Hydrogen Electrode). In the over-voltage calculation we take into account the fact that the peak-up electrode surrounded by the D_2 gas is not a platinized Pt, but just a pure Pt: this difference is reported by the literature to be 0.09 V for H_2 gas; we consider this value for our calculations. The over-voltage can be related to the Deuterium concentration into the Pd electrode (fig.s 4.b ,4.c); sudden drops of the over-voltage (fig. 4.c) seem to indicate partial degassing effects occurred on the surface zone for the Pd sheet.

The following operating conditions have been used for the T18 plate: peak current pulse 16 A, pulse width 1.8 μ s, pulse repetition rate 2 KHz (mean current equivalent to 64 mA).

In figure 5.a we observe, regarding the α and the $\alpha+\beta$ phases, a curve shape similar to one of the plate previously described. As shown in figure 5.b, the D/Pd value was going to reach a plateau at 0.75, then we increased the peak current to 32 A and we reduced the pulse repetition rate down to 1 KHz as such as to maintain the same mean current at 64 mA: the absorption rate increased and the D/Pd too. To increase further this value we operated at 45 A and 750 Hz and after that at 60 A and 500 Hz, in both cases the mean current was kept constant at 64 mA. The final D/Pd value reached was 0.95. In figure 5.a negative values of absorption rate correspond to a short discharge occurred during the performed operation. In figure 5.c the over-voltage apparently increased in respect to the previous case described, because of the increase of peak current density (this value should be corrected by the Tafel contribute). In this way we want to stress that is possible to increase the D/Pd value operating on the peak current and the frequency of the pulses.

The operating conditions of the I85 plate (182 Hv) are the same of the T05 plate.

Observing the figure 6.a, the curve shape of the absorption rate is quite different from the T05: the shoulder occurring at the $\alpha+\beta$ phase is nearly completely disappeared. This plate reaches, as shown in figure 6.b, the highest D/Pd value (1.2:1) ever reached in our experiments. The over-voltage increases up to a very high value (1.61 V) as reported in figure 6.c, but it sharply decreases when the D/Pd value is about 0.9. After this value the over-voltage is no more steady and slowly decreases in time. Perhaps it means that something of disrupting is occurred on the plate surface.

In this last experiment a direct Deuterium absorption control was performed by the weight of the Pd plate: we stopped the electrolysis and we weighted it, after that we warmed the plate for many hours at the temperature of 250 °C and we weighted again the plate (the mass

difference corresponds to the whole Deuterium flown out from the Pd). This measurement confirmed the high D/Pd value (> 0.95) found during the charging-up.

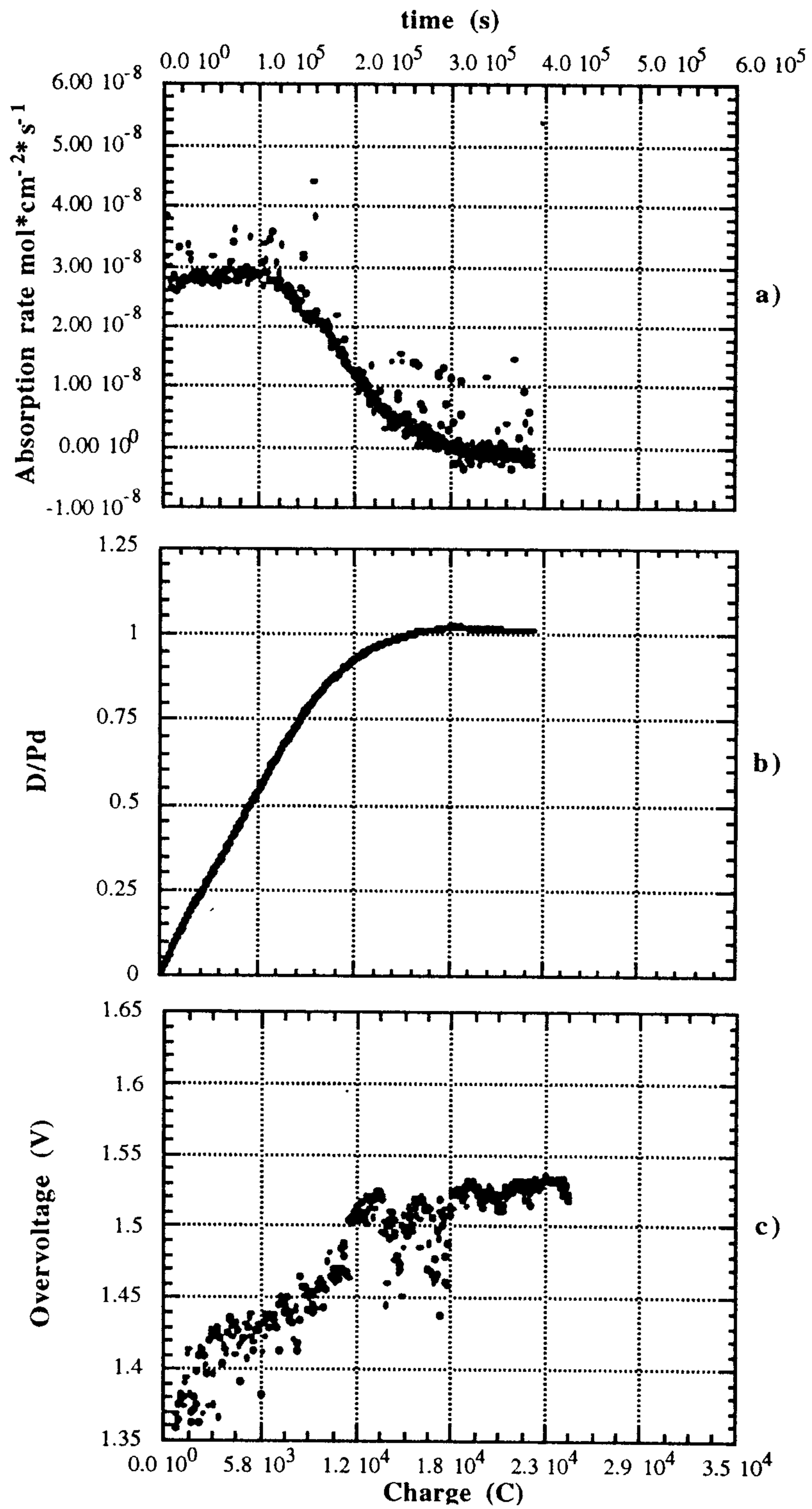

FIG. 4 – T05 Pd plate: first charging up.

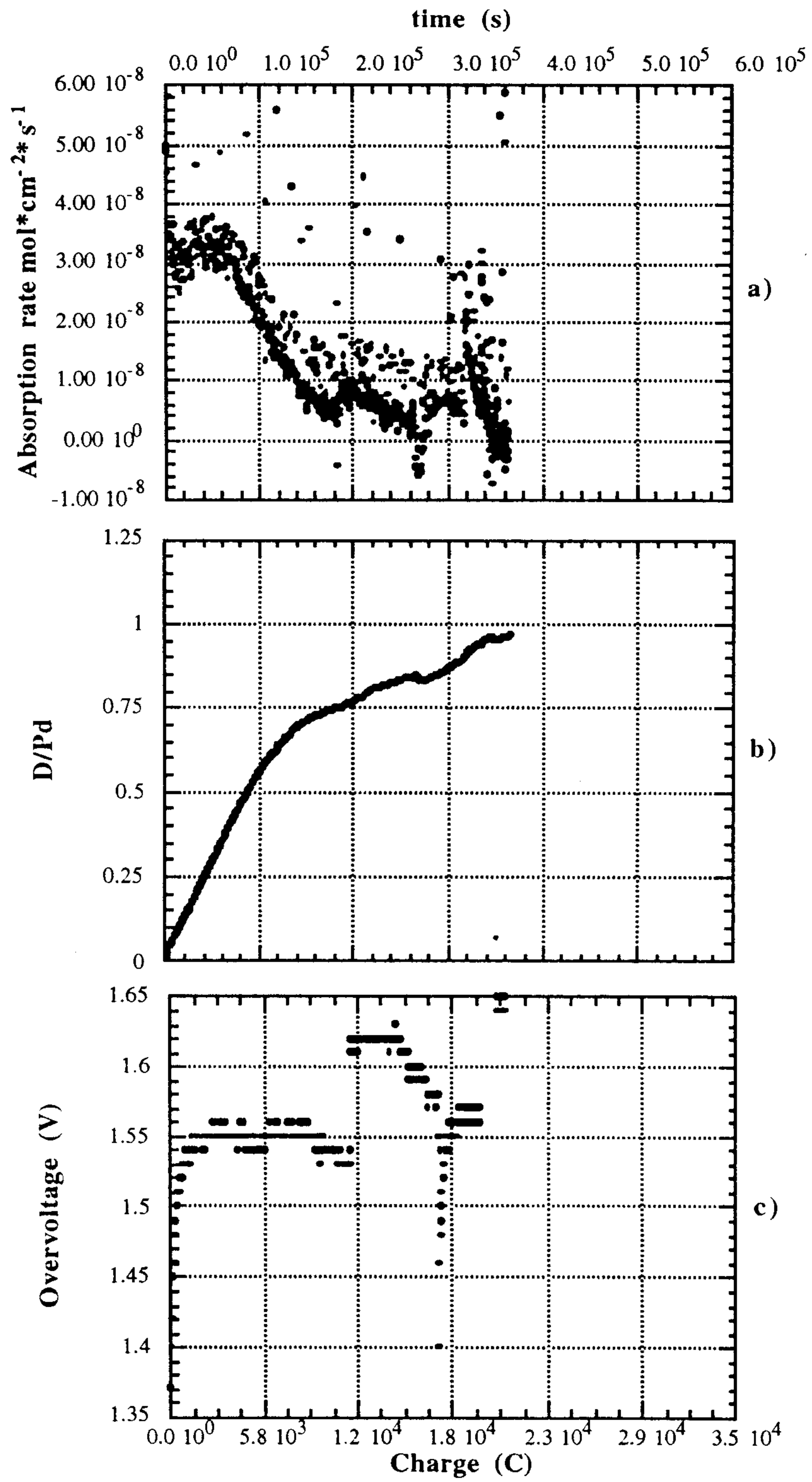

FIG. 5 - T18 Pd plate: first charging up.

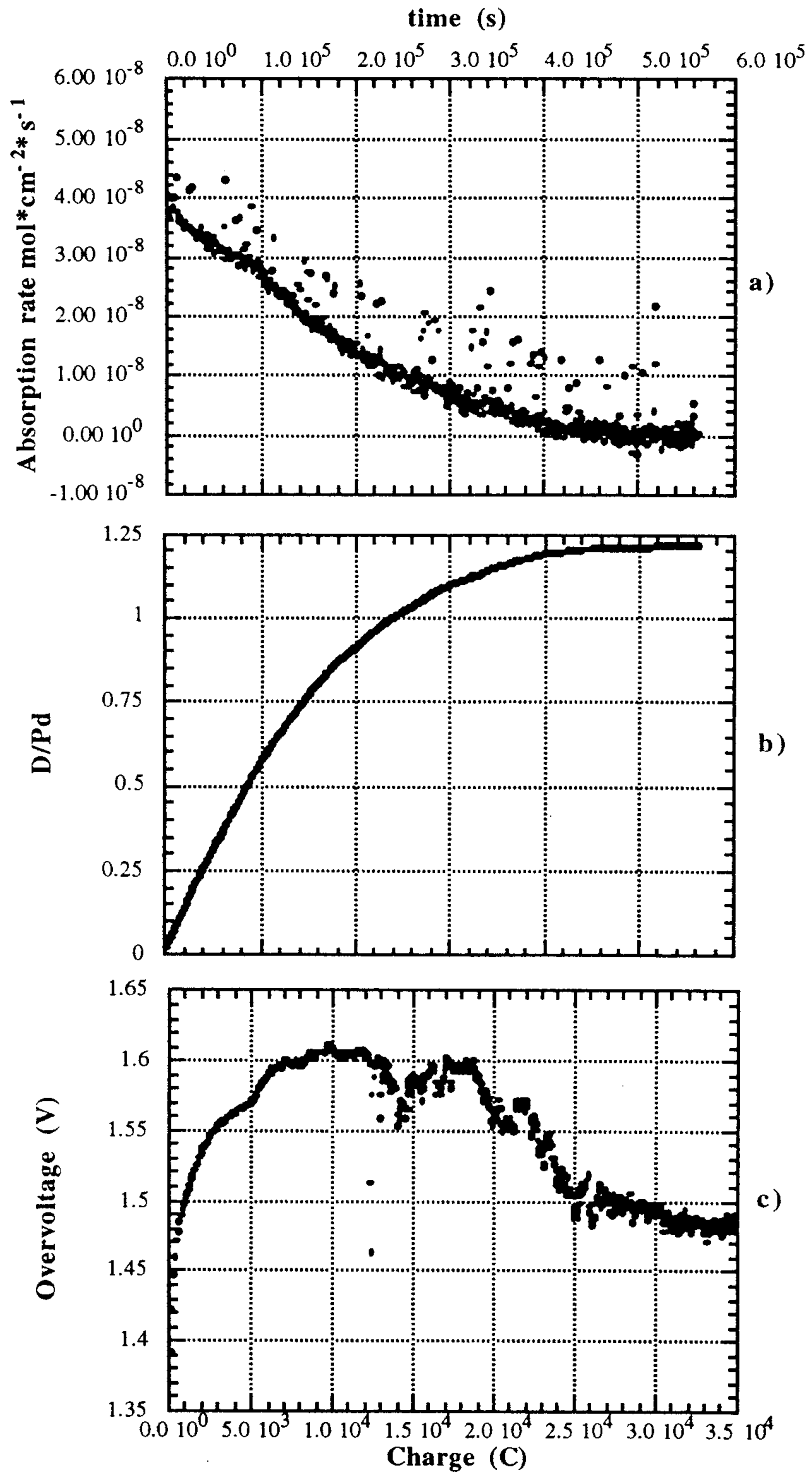

FIG. 6 - 185 Pd plate: first charging up.

3. - EXCESS HEAT RESULTS

Blank tests, using Au plate instead of Pd, were performed. These tests were used as a reference to calculate the input/output energy involved in the pulsed electrolysis process, as well as the absorption rate and the over-voltage parameters. Several operating conditions, about the pulses, were tested and changed: peak amplitude, repetition rate, width.

The T18 plate was tested along about 2 months: it presented a detectable excess heat already a few days after the first charging up. During this time, many operations were performed to discover if there were a correlation between the type of the pulse and the excess heat. No relevant dependence was found in the frequency range (from 5 to 20 KHz) that we explored. In figure 7 we report the comparison between the Au and Pd plate operating in the same conditions: the pulse peak current was about 60 A and the width 0.5 μ s. The effective input power was calculated as the product of single pulse electric energy times pulses repetition rate (the heavy water dissociation contribute was subtracted). The output power is the thermal energy per time unit measured by the flow calorimeter (the thermal dissipation contribute is not included). As shown in figure 7, the output power measured using the Pd plate is always larger than the Au blank reference plate and if we try to fit the curves, the relative excess power corresponds to a +12%. Operating at 15 KHz, this effect was mainly steady (about +15%) along some weeks.

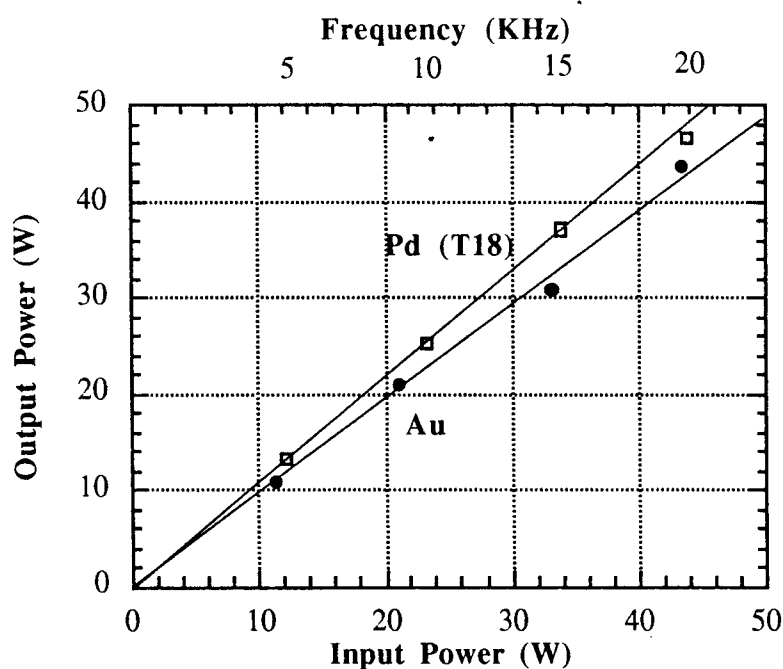

FIG. 7 - Excess power: T18 Pd respect to Au.

The T05 and I85 were tested for about 2 weeks in stationary conditions: peak current about 16 A, width 500 ns and repetition rate of 5 KHz. No relevant excess heat (< 5%) was found and tests have been stopped.

In Table I are reported the main parameters and properties of the three Pd plates.

TABLE. I - Values of Pd plates and Au reference plate.

Plate	Au	T05	T18	I85
Hardness (HV)	60Rk	300	300	182
Density	19.31	11.90	11.90	11.99
Process made	Fus	C-W	C-W	C-W
Load efficiency (%)		α	56	71
		β	71	64
Max D/M	0.01	1.00	0.95	1.20
Var.Overvolt (mV)		340	400	240
Max Overvolt (mV)		1530	1650	1620
Rmax-Rmin (Ohm)	0.06	0.17	0.10	0.32
<DW/W> (%)	0	< 5	15	< 5
Peak current (A)	16	16	16	16
Mean current (mA)	64	64	164	64
Rep.tion-rate (KHz)	5	5	5	5
Pulse width (ns)	500	500	1800	500
Impurity (ppm)	<100	2700	2700	<300

4. – METALLURGICAL ASPECTS

All the Pd plates tested had cold worked treatments operated with different procedures. The hardness parameter is the value that we use to indicate the quality of the cold working procedure. This parameter is increased by the cold working from a value of 50 Hv (ordinary Pd) to about 180 Hv. In the case of Tanaka plates some impurities were intentionally added to the Pd in order to increase this value up to 300 Hv (CTC material).

There are clear indications that the absorption rate is a function of the plates hardness. In particular, the plates with higher value of hardness (300 Hv) show a high and constant absorption rate in the α and $\alpha+\beta$ phases up to D/Pd equal to 0.67. Further on, the absorption rate starts to exponentially decrease until that the equilibrium condition has been reached: no Deuterium is adsorbed and the D/Pd curve reaches a plateau. As regards the plates with lower value of hardness (180 Hv), we only observed an absorption rate with a decreasing exponential behaviour. Furthermore, higher hardness seems to negatively affect D/Pd charging ratio (taking into account this parameter only, IMRA MATERIAL samples appeared to be remarkably better).

Regarding the electric resistance, very large differences has been detected. In figures 8 are reported the electric resistances (as the ratio between the mean voltage and mean current of the cell) of T05 and I85 versus the D/Pd ratio. The I85 low hardness plate shows (fig. 8.b) a shape very similar to the ordinary curve (as reported by ⁽²⁾ 'Bockris et al') having a maximum at 1.1:1 D/Pd (in ⁽²⁾ it is at 0.85: beginning of γ phase). The T05 (fig. 8.a) high hardness plate has a different shape: the maximum value is at 0.1 D/Pd (end of α phase) and it is evident a

drop at 0.8. Such anomalous behavior could be explained considering that a skin effect could occur because of the fast rise time (hundred nano-seconds) of the pulse; probably in such thin skin a strong and fast Deuterium charging occurs.

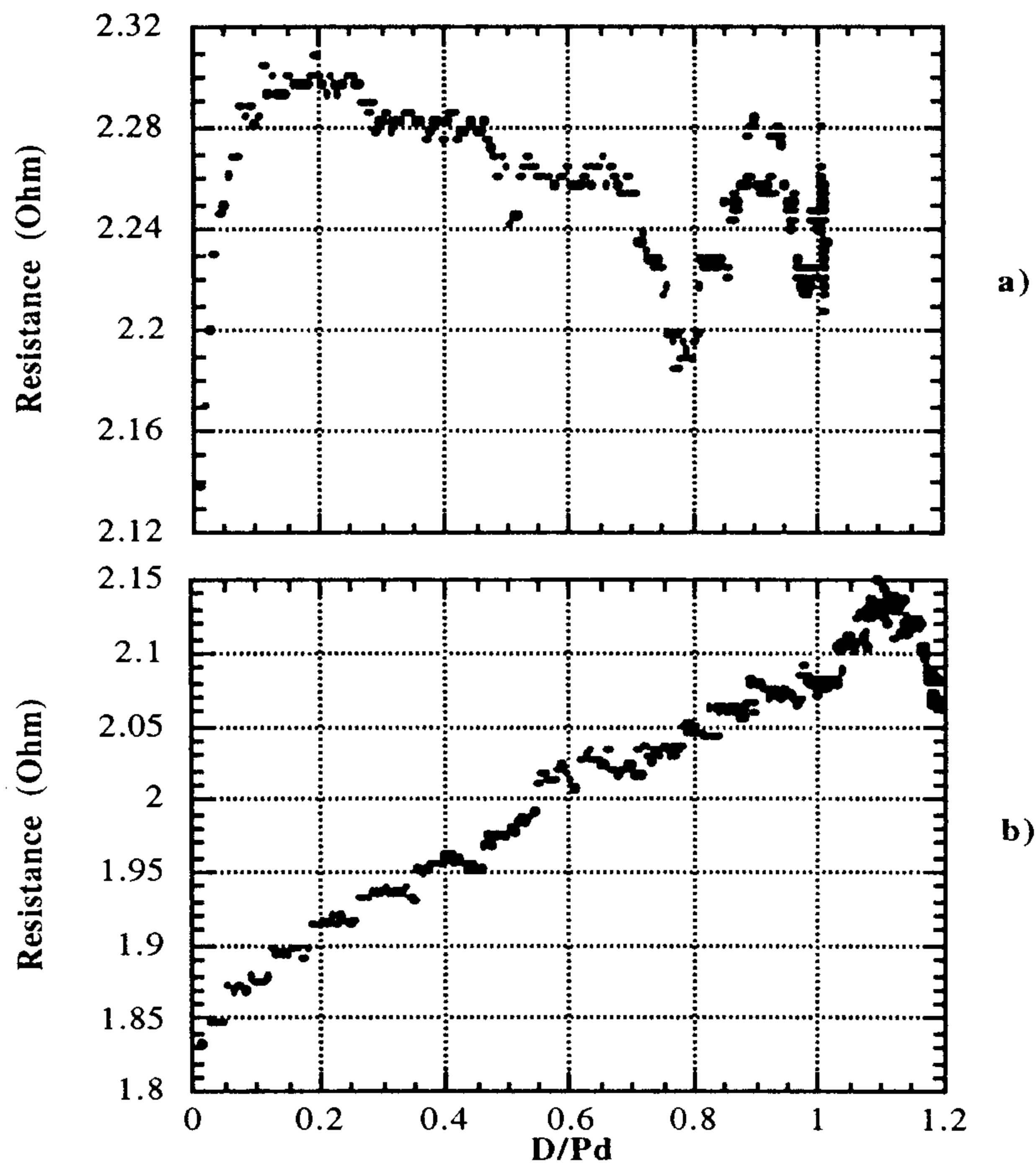

FIG. 8 – Resistance vs D/Pd: a) T05; b) I85.

We would like to anticipate that the ionic Li, present in the solution, can play an important role, depending by the metallurgical proprieties of the surfaces. In such a way, the over-voltage and plate surface resistance parameters could give strong indications about surface modifications during the charging up. In order to better understand these effects, some Au plates were used instead of Pd plates. In this way the Deuterium absorption effect on the surface was minimized and it is possible to better identify the role played by the Li or Li compounds (like LiD) on the surface itself.

We like to note that exist a parameter, closely related to the D/Pd value, achieved after long-time electrolysis. It is represented by the η_2 component of the over-voltage, namely the total over-voltage without the η_1 ^(3,4) contribute due to the “Tafel” current density. We observed, keeping unchanged the pulse shape ($t_{width}=500ns$, $I_{peak}=16$ A and $\nu=5KHz$), that the η_2 parameter has different behaviours, related to the D/Pd ratio, depending by different plate hardness.

Specific studies about these latter parameters and the role of Li are in progress.

CONCLUSION

Independently by the metallurgy of the Pd electrodes, we developed an high pulse technique to highly charge Pd plates (D/Pd around 1:1). However, the metallurgy of the plates affects the absorption rate “shape” parameter. The over-voltage and electric resistance parameters give useful indications about the Pd plate surface status during the Deuterium absorption. An important role can play the ionic Li on the surface, in particular way when the Pd plate reaches high D/Pd values.

The excess heat occurring for some Pd plates seems dependent by the metallurgy of the electrode: a high hardness plates (doped by proper impurities) can give excess heat (around 15% in our case) for very long time (some weeks). This condition seems to be necessary but not still sufficient, because the first charging-up procedure seems to play an important role depending on the samples hardness. Moreover, observing the plates at the end of the tests, we can point-out that the excess heat occurs when there were no cracks on the plate surfaces. In other words the peak pulse current should be limited to avoid disrupting effects to the plates.

ACKNOWLEDGEMENTS

We are indebted to both Dr. K.Mori and Drs. M.Nakamura (TANAKA K.K.) because their time spent to developed the new Pd-CTC material (patenting) just starting from an our original idea. We cannot forget Dr. S.Nezu (IMRA MATERIAL) because provided us not only with pure Pd plates of very different metallurgical properties but even of very usefull suggestions.

We would like to thank Prof. G.Preparata (Milan Univ., Italy), Prof. H.Ikegami (NIFS, Nagoya, Japan), Prof. J.P.Vigier (Paris Univ., France), Dr. K.Kunimatsu (IMRA-Japan), Prof. M.Enyo (Hokkaido Univ., Japan) and Dr. A.Mancini (ORIM S.r.l., Italy) for their stimulating discussions, criticism and suggestions.

We are grate to Drs F.Ferrarotto, M.Corradi and Prof. B.Stella (Rome Univ., Italy) for their suggestions.

The palladium plates were kindly provided from Tanaka K.K. and IMRA MATERIAL, both from Japan.

Other palladium samples, for calibration purposes, were provides by ORIM S.r.l., Macerata (Italy).

One of the author, P.T., thanks ORIM S.r.l., Macerata (Italy) for financial support.

REFERENCES

1. F.Celani, A.Spallone, P. Tripodi, A. Nuvoli, FRONTIERS OF COLD FUSION, Edited by H.Ikegami, p.93 (1992) Frontier Science Series n.4, Univ. Acad. Press, Tokyo (Japan).
2. M.C.H. McKubre et al, FRONTIERS OF COLD FUSION, Edited by H.Ikegami, p.5 (1992) Frontier Science Series n.4, Univ. Acad. Press, Tokyo (Japan).
3. M. Enyo, FRONTIERS OF COLD FUSION, Edited by H.Ikegami, p.255 (1992) Frontier Science Series n.4, Univ. Acad. Press, Tokyo (Japan).
4. K. Kunimatsu et al, FRONTIERS OF COLD FUSION, Edited by H.Ikegami, p.31 (1992) Frontier Science Series n.4, Univ. Acad. Press, Tokyo (Japan).