

LNF - 63/67

11 Novembre 1963.

G. Pasotti, N. Sacchetti, G. Sacerdoti and G. Sanna: SOME
EXPERIMENTAL RESULTS OF SUPERCONDUCTING
SOLENOID SOLENOIDS. -

Nota interna : n. 217

SOME EXPERIMENTAL RESULTS OF SUPERCONDUCTING SOLENOIDS.

G. Pasotti, N. Sacchetti, G. Sacerdoti, G. Sanna
Laboratori Nazionali del CNEN Frascati-Italia

ABSTRACT.

Phenomena which limit the performance of superconducting solenoids are reviewed, and the experimental data obtained in designing, building and testing several coils employing Nb-Zr wires at different percentages of Zr is summarized.

A superconducting solenoids is described in which a field of 49.3 kG was obtained in an internal region of diameter 1 cm and height 7 cm. The results obtained with other coils of smaller dimensions and lower maximum field are tabulated.

In addition, measurements of the residual magnetic field fields are reported, as well as a brief description of the experimental apparatus.

SOME EXPERIMENTAL RESULTS OF SUPERCONDUCTING SOLENOIDS.

G. Pasotti, N. Sacchetti, G. Sacerdoti, G. Sanna
Laboratori Nazionali del CNEN Frascati-Italia

INTRODUCTION.

At the present time it is possible to construct high magnetic field solenoids by taking advantage of the exceptional properties exhibited by certain superconducting (s.c.) alloys⁽¹⁻⁹⁾.

Such alloys, whose behaviour is very similar to hard superconductors, exhibit a number of characteristics which are very sensitive to the crystalline state of the material.

Approximate curves of $J_c(H_c)$ and $H_c(T)$ ^(*) are shown in Fig. 1 and 2 for the alloys and intermetallic compounds (Nb-Zr, Nb₃Sn, Va₃Ga) of most interest at present for the construction of magnets.

From these curves we see that the critical current in these materials remains large even in the presence of strong magnetic fields.

This is, in short, the physical phenomenon which allows the realisation of coils able to attain high fields.

The metallurgical techniques involved in the fabrication of these alloys is especially complex⁽¹⁰⁾, particularly with regard to obtaining wires of sufficient mechanical strength and flexibility to be wound into coils. At the start of the experiments described in the present paper we direct our attention to Nb-Zr solenoids because the alloys of such metals, even though their s.c. properties are inferior to the other two compounds mentioned above, are the only products commercially available in wire which is easy to handle.

(*) - For the meaning of the symbols used, see the mentioned figures.

The magnets constructed of niobium-stannide (Nb_3Sn) were, until recently, prepared by delicate and complicated procedures^(8,11) which lead to an especially brittle wire structure, thus making recovery and reuse of the wire in other experiments impossible. This fact made experiments with such conductors particularly expensive.

Recently, however, flexible Nb ribbons have been realized over which Nb_3Sn has been deposited by a special procedure and which can be directly utilized for winding without any need of further heat treatment^(x) (12).

1. PHENOMENA WHICH LIMIT THE PERFORMANCE OF SUPERCONDUCTING SOLENOIDS.

The most important information which must be known in order to design a s.c. solenoid is the curve which relates the critical current to the critical magnetic field for the material selected. The practical possibilities of constructing magnets of large dimensions, which can be used for research applications, depend on the behaviour of this curve and on the cost of the material. This curve $I_c(H_c)$ is very dependent on the metallurgical treatment which the alloy has undergone^(13,14); it depends on the temperature and on the annealing time of the material, on the hardening, on the impurities present (especially oxygen and carbon), and also, for conductors which have a diameter less than one millimeter, on the surface condition.

Also, the etching^(o) of the wire and the type of insulation, in case this is obtained by electrolytic metallic deposit, influence the superconducting properties of the material. When the curve $I_c(H_c)$ and the geometry of the winding are known, the maximum magnetic field theoretically obtainable may be calculated immediately⁽¹⁶⁺²¹⁾. However, in practice the maximum current which the solenoid can carry is in general less than the theoretical value, and consequently the value of the field is less than that predicted.

Many reasons have been suggested to explain this phe-

(x) - See, for instance, the "Niostan Ribbon" of the National Research Corp. Cambridge, Mass., U.S.A.

(o) - The etching⁽¹⁵⁾, because of surface contamination of hydrogen, increases the critical current.

Physically, it is thought that these dipoles are associated with local crystalline deformations or with chemical impurities, which appears plausible because many properties of "hard" superconductors are related to such factors.

From what has been said, it is clear that these dipole currents, superimposed on the excitation current, can bring some zone of the coil to critical conditions before such conditions are reached throughout the solenoid.

Research on these limiting factors for superconductive solenoids has not yet provided definitive conclusions. Nevertheless, superconducting coils of satisfactory performance have been constructed (16, 17, 18).

2. EXPERIMENTAL APPARATUS.

In the course of experimentation, the coils of external diameter less than six centimeters were tested in ordinary glass dewars. For magnets of greater diameter, a special stainless steel dewar was constructed, schematically illustrated in figure 3 (see also fig. 4).

The helium consumption of the dewar, equipped with all the apparatus for the experiment (including three copper conductors of mean diameter 1,5 mm which enter the helium bath from above) was about 1 liter/hour (in good agreement with the calculations). The consumption (calculated) of the dewar alone was 0,25 liter/hour.

To excite the coils, a circuit, employing transistors and batteries at low voltage (6 volt), was used, able to deliver a maximum current of 50 A with very fine regulation of the current itself by means of a helipot potentiometer.

To measure the magnetic field, a search coil connected to an electronic integration fluxmeter was used. We should note that the contacts between the power supply bars and the superconducting wire were made in two different ways:

- a) pressing a 20 cm length of Nb-Zr wire between two well-cleaned discs of copper.
- b) ultrasonic soldering using pure indium as soldering material.

To join the various pieces of superconducting wire, both electric spot welding and ultrasonic soldering was employed. All three of these types of contact proved, in numerous

trials, able to carry currents above the maximum current of our power supply (50A) without losing superconductivity.

3. RESULTS OBTAINED.

For the construction of our solenoids we used Nb-Zr wire of 0,25 mm diameter, with various percentages of Zr^(*).

Tables I and II summarize, respectively, the principal construction data and the experimental results for our coils, excluding those which gave less interesting results.

The values of field and current given in table II are those just below the transition to the normal state. The value of the transition current was read directly from the power supply ammeter, whereas the maximum field was determined by extrapolating the excitation characteristic (straight line) of the solenoid, obtained experimentally, to that value of current.

The coil D, which gave the best result, was constructed of four concentric sections whose dimensions and number of turns are shown in fig.5. The first measurement performed with this coil was that of the maximum current which could be carried by each section, leaving the other three not excited. The results were as follows:

section 4	$I_{c4} = 6,5 \text{ A}$
section 3	$I_{c3} = 13,5 \text{ A}$
section 2	$I_{c2} = 15 \text{ A}$
section 1	$I_1 = 14 \text{ A}$

Section 1 did not "collapse" for $I = 14 \text{ A}$ and furthermore, exciting section 3 as well with an increasing current, while section 4 remained excited, there was destruction of the superconductivity in both sections only for $I_3 = 12 \text{ A}$; this suggests that a current considerably greater than 14 A is necessary, to bring section 1 to the normal state and probably greater than 15 A for section 2.

This linearly-increasing dependence of the critical current, going from the external to the internal section, enhances the hypothesis that this current is considerably affected by the form of the section, whereas the current did not appear

(*) - This wire was furnished to us by the Wah Chang Corporation, Albany, Oregon, U.S.A.

much affected by the length of the wire in the section (in fact, section 4 is much shorter than section 3).

The values of the critical currents given above, as well as other preliminary experiments, lead us to not use section 4 and to excite the other three sections in series in order to test for the maximum field obtainable with coil D.

In addition to the measurements given above, we have measured the behaviour of the axial component of the residual magnetic field along the axis of symmetry for coils B and C. The measurements were taken after having excited the coil with a current slightly less than the critical current indicated in table II (except for coil C) and then having brought back the current to zero without losing the superconducting state.

The results are plotted in fig. 5(a) and (b). These results seem to agree with those of other experimenters^(27,28), that is:

- a) the axial distribution of this field is approximately symmetrical, with respect to the center of the coil.
- b) the residual magnetic field is a maximum near the ends of the coil.
- c) the direction of this field is usually opposite to that of the principal field produced during the excitation.

We also noted that coil B, which reached a magnetic field stronger than that of coil C (see table II), had a much higher residual field.

Finally, measurements performed after the loss of superconductivity showed a residual magnetic field with a very irregular axial distribution.

CONCLUSIONS.

We have found, as have other researchers, that is impossible in the design stage to predict the performance of a superconducting coil because of the different behaviour of a piece of wire and the same wire wound in a coil. This is due, as we have pointed out in the preceding paragraphs, to causes still under investigation.

We have also found the lack of complete reproducibility of the performance of the coils in a given series of trials, as well as in successive trials.

Among the causes of non-reproducibility, some of the

phenomena, mentioned in paragraph 1 as limiting the performance of solenoids, may also be enumerated (for example, the "training", local annealing of the wire caused by transitions to the normal state, residual fields, etc.). Furthermore, it is not possible to exclude various phenomena, such as mechanical vibrations and shocks, electrical oscillation caused by the high inductance, the high stray capacitance, and the very low resistance of the circuit. As for the first of these two causes, it may be pertinent to observe that we noticed that the flux trapped in a small lead superconducting ring can be made to decay by repeated mechanical shocks.

It appears interesting to observe that a considerable quantity of magnetic energy is concentrated in a small volume, and that rough calculations for magnets near transition show that this stored energy is of the order of magnitude of the total energy necessary to make the superconducting electrons go into the normal state.

The authors wish to thank Prof. I.F. Quercia, director of the Laboratori Nazionali di Frascati, for having permitted and encouraged the present work.

They are also pleased to thank Drs F. Scaramuzzi and I. Modena of the local Cryogenic Laboratory for assistance and useful suggestions.

Particular thanks go to the technicians Mr. A. Catitti, for his collaboration in the design of the metallic dewar, and Mr. A. Bianchini, for his patient and competent work in winding all our solenoids.

FIGURE CAPTIONS.

FIGURE 1. - Approximate behaviour of the critical current density (J_c) as a function of the applied external magnetic field (H_e) for various types of superconductors:

- curve A - wire of Nb - 25% Zr, $\phi = 0,25$ mm } (from the Wah Chang
curve B - wire of Nb - 33% Zr, $\phi = 0,25$ mm } Corp., Albany, Oregon,
U.S.A.)
curve C - ribbon of Nb with an external layer of Nb₃Sn, of over-
all cross section $1,6 \times 3 \cdot 10^{-2}$ mm². ("Niostan Ribbon"
of the National Research Corp, Cambridge, Mass, U.S.A.)
curve D - Cylindrical conductor with a Nb outer shell and a
Nb₃Sn inner core. $\phi_{ext.} = 0,38$ mm, $\phi_{int.} = 0,15$ mm.

The dotted part of curve D and the shaded area indicate the uncertainty of the knowledge of J_c over 100 kG.

FIGURE 2. - The Approximate behaviour of the critical magnetic field (H_c) as a function of the temperature (T) for the inter-metallic compounds V₃Ga and Nb₃Sn. The shaded area shows the uncertainty of the existing knowledge of the critical magnetic field.

FIGURE 3. - Schematic view of the metallic dewar used in the experiments with coils of diameter larger than 6 cm. All parts of the dewar are of stainless steel except those otherwise indicated in the figure.

All dimensions indicated are in millimeters.

FIGURE 4.- View of dewar shown in axial section in fig.3. The vacuum system and part of the helium recovery line are visible.

FIGURE 5. - Schematic view of coil D ($H_{max} = 49.3$ kG). The external and internal diameters of the four sections and the number of turns are shown.

FIGURE 6. -

a) Map of the axial component of the residual magnetic field measured along the axis of solenoid B. The ordinates are

normalized to 1 in correspondence with the maximum value of H_s
($H_s \text{ max} = 730 \text{ G}$).

b) Similar map for solenoid C ($H_s \text{ max} \approx 40 \text{ G}$).

NOTE: The curve shown in fig. 6(a) was obtained after having excited the solenoid to a current slightly less than the critical current indicated in table II and after having reduced the current to zero without losing the superconducting state; while the curve of fig. 6(b) was obtained after having excited the ~~curve C~~ *coil* to the field indicated in table II.

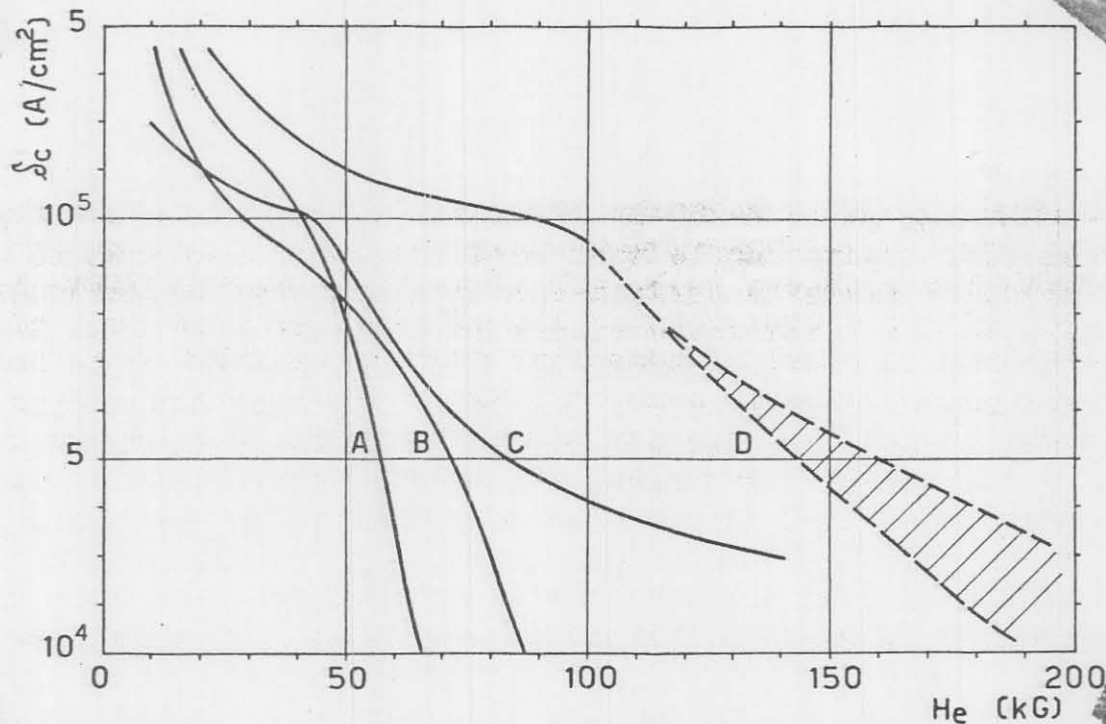

FIG. 1 - Approximate behaviour of the critical current density (J_c) as a function of the applied external magnetic field (H_e) for various types of superconductors:

- curve A - wire of Nb - 25% Zr, $\phi = 0.25$ mm } (from the Wah Chang Corp.
- curve B - wire of Nb - 33% Zr, $\phi = 0.25$ mm } Albany, Oregon, USA)
- curve C - ribbon of Nb with an external layer of Nb₃Sn, of overall cross section $1.6 \times 3 \times 10^{-2}$ mm² ("Niostan Ribbon" of the National Research Corp., Cambridge, Mass., USA)
- curve D - cylindrical conductor with a Nb outer shell and a Nb₃Sn inner core - $\phi_{ext} = 0.38$ mm; $\phi_{int} = 0.15$ mm.

The dotted part of curve D and the shaded area indicate the uncertainty of the knowledge of J_c over 100 kG.

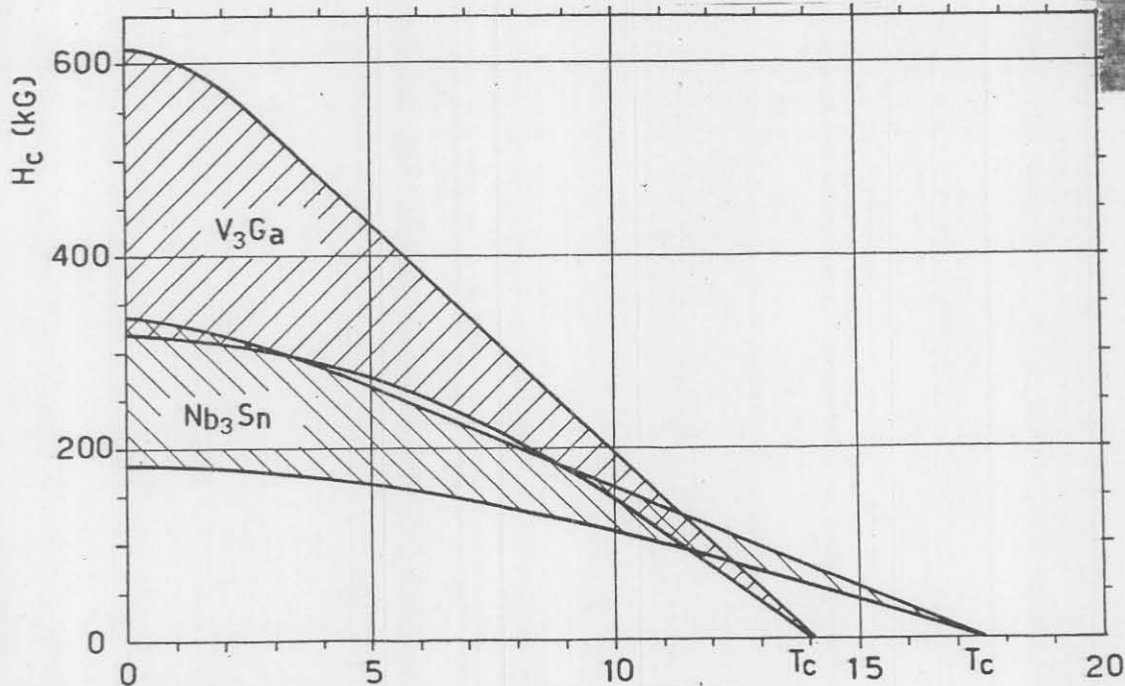

FIG. 2 - Approximate behaviour of the critical magnetic field (H_c) as a function of the temperature (T) for the intermetallic compounds V₃Ga and Nb₃Sn. The shaded area shows the incertainty of the existing knowledge of the critical magnetic field.

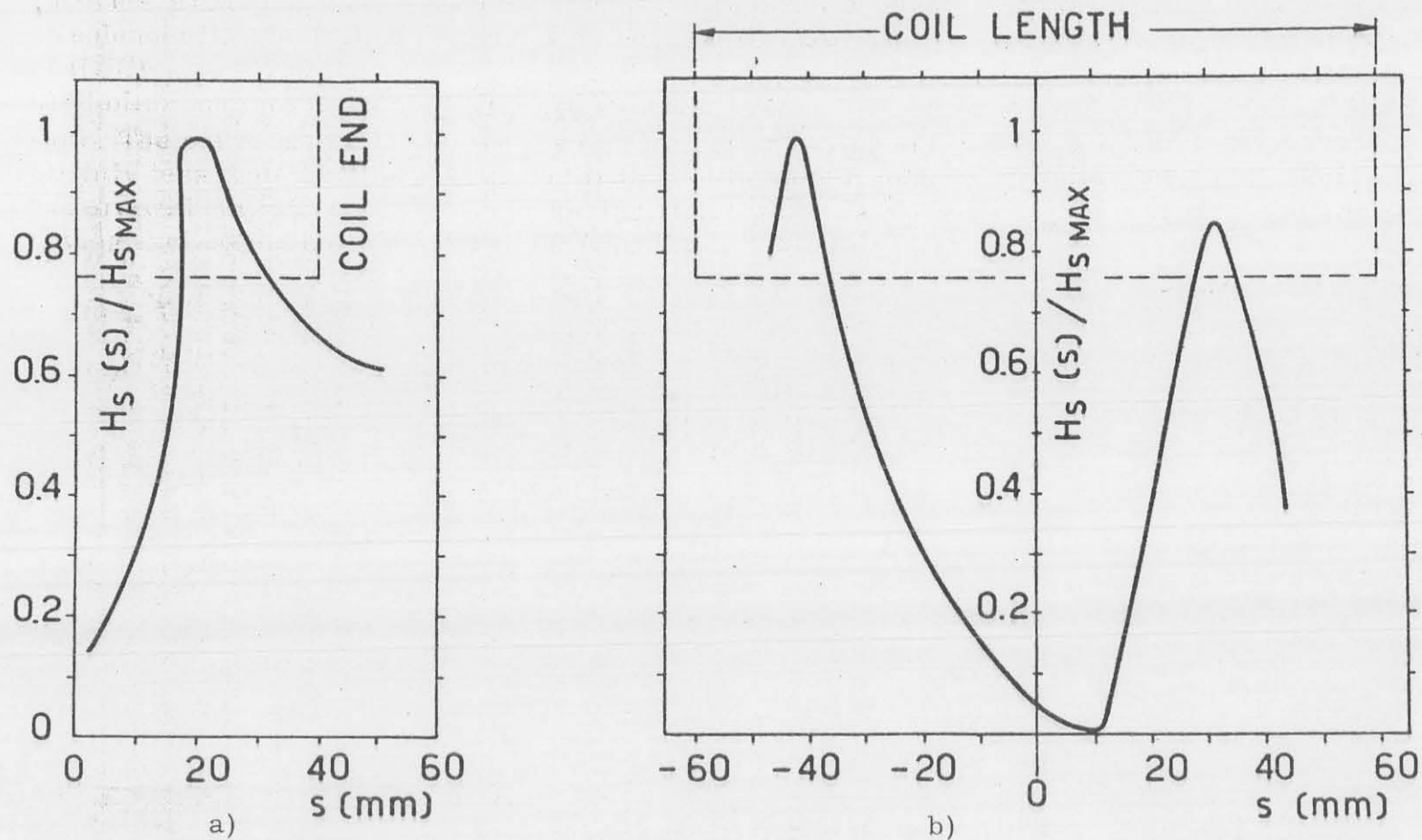

FIG. 6 - a) Map of the axial component of the residual magnetic field measured along the axis of solenoid B. The ordinates are normalized to 1 in correspondence with the maximum value of H_s ($H_{smax} = 730$ G).

b) Similar map for solenoid C ($H_{smax} \approx 40$ G).

Note: The curve shown in fig. a) was obtained after having excited the solenoid to a current slightly less than the critical current indicated in table II and after having reduced the current to zero without losing the superconducting state; while the curve of fig. b) was obtained after having excited the coil C to the field indicated in table II.

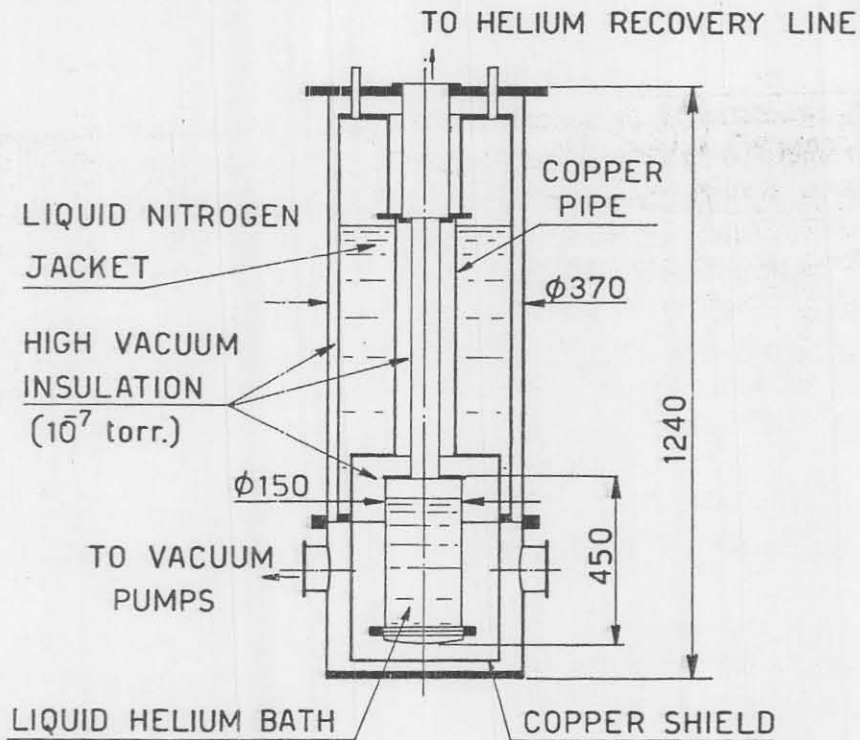

FIG. 3 - Schematic view of the metallic dewar used in the experiments with coils of diameter larger than 6 cm. All parts of the dewar are of stainless steel except those otherwise indicated in the figure. All dimensions indicated are in millimeters.

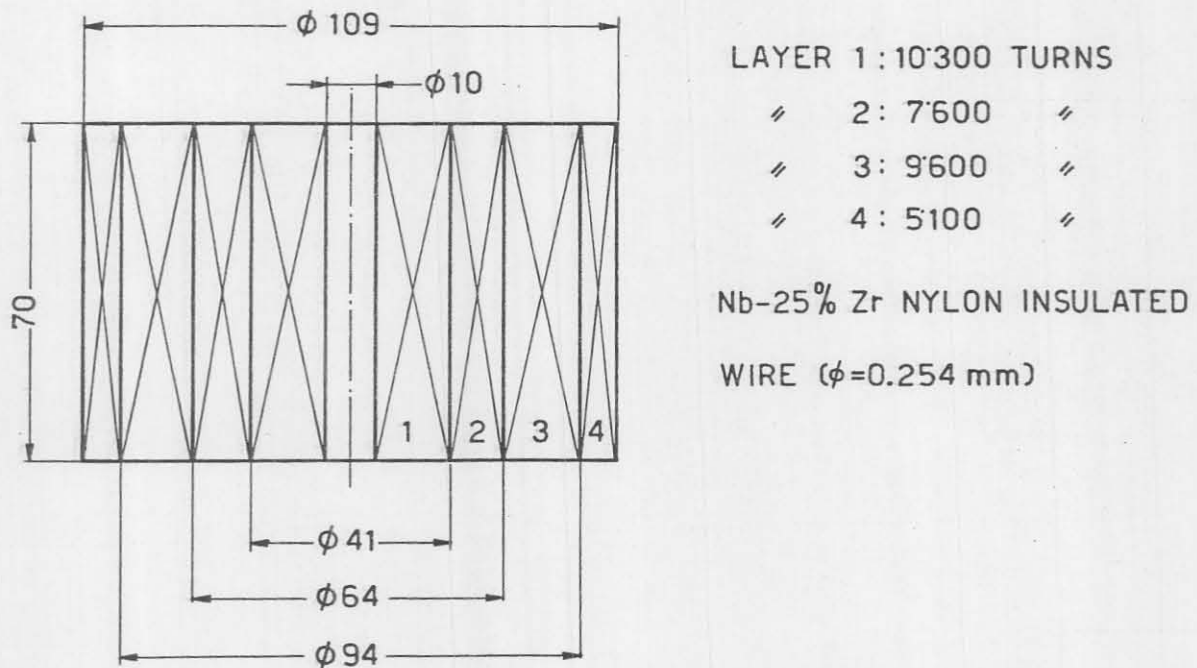

FIG. 5 - Schematic view of coil D ($H_{\max} = 49.3$ kG). The external and internal diameters of the four sections and the number of turns are shown.

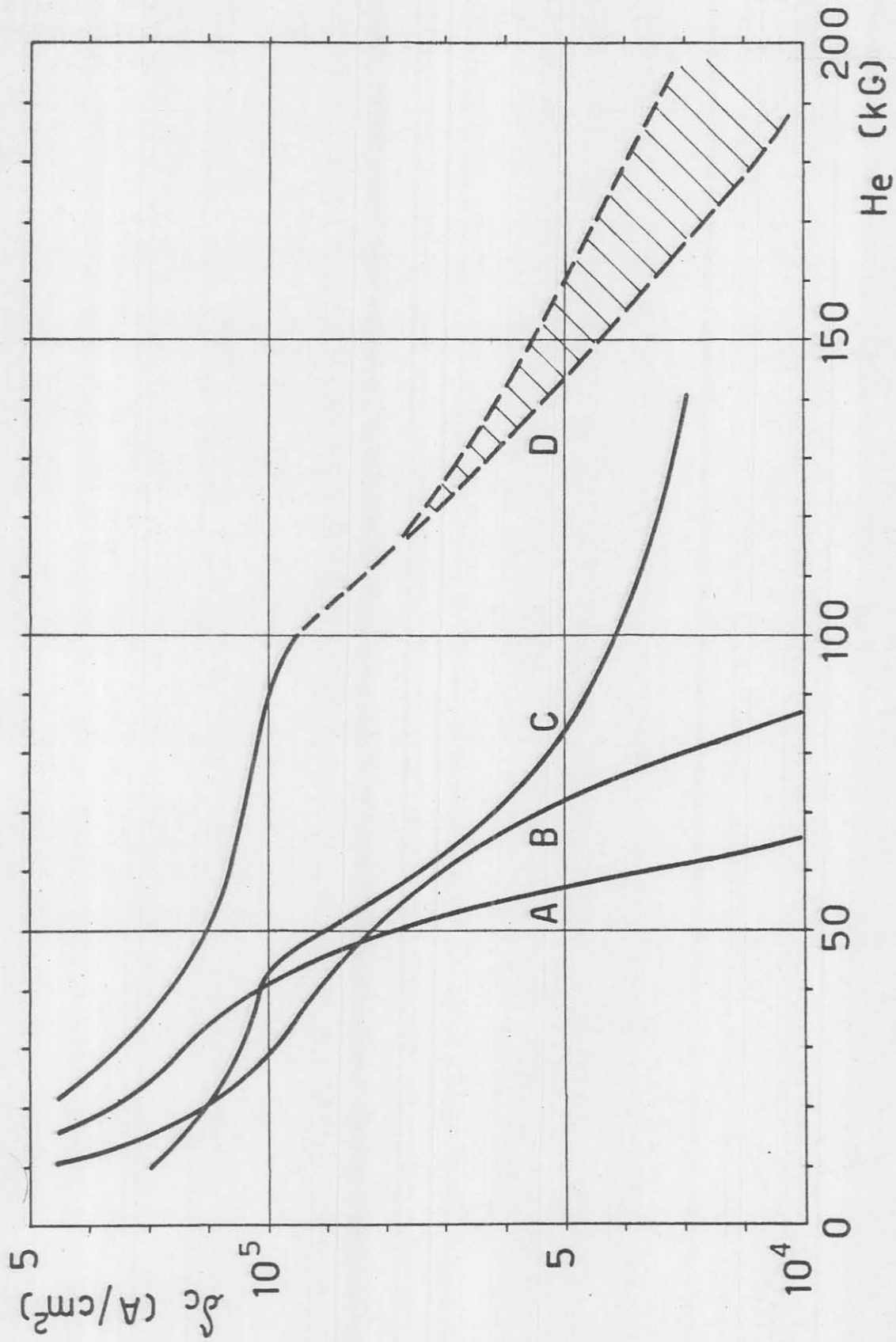

FIG.-1-

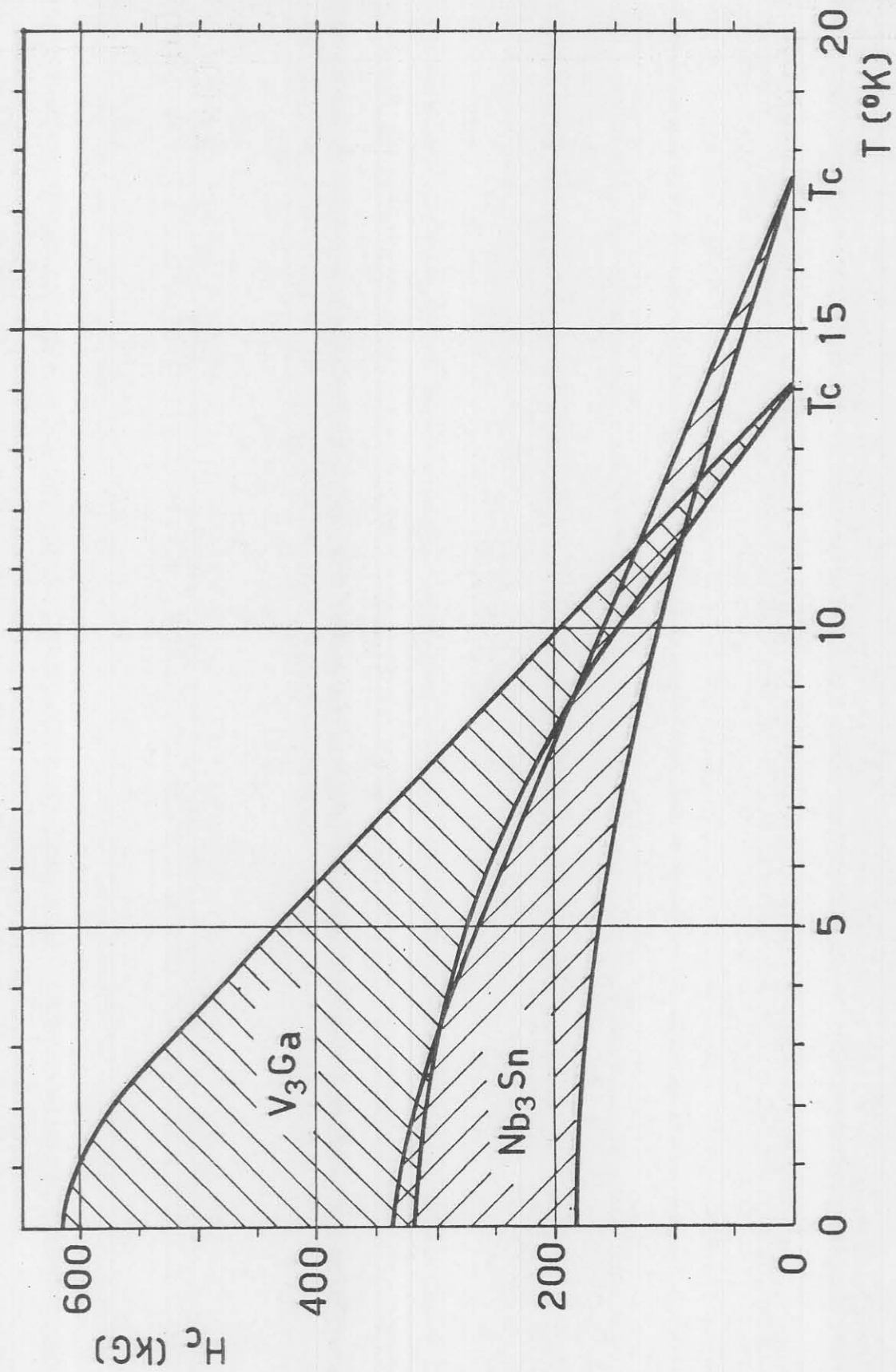

FIG.-2 -

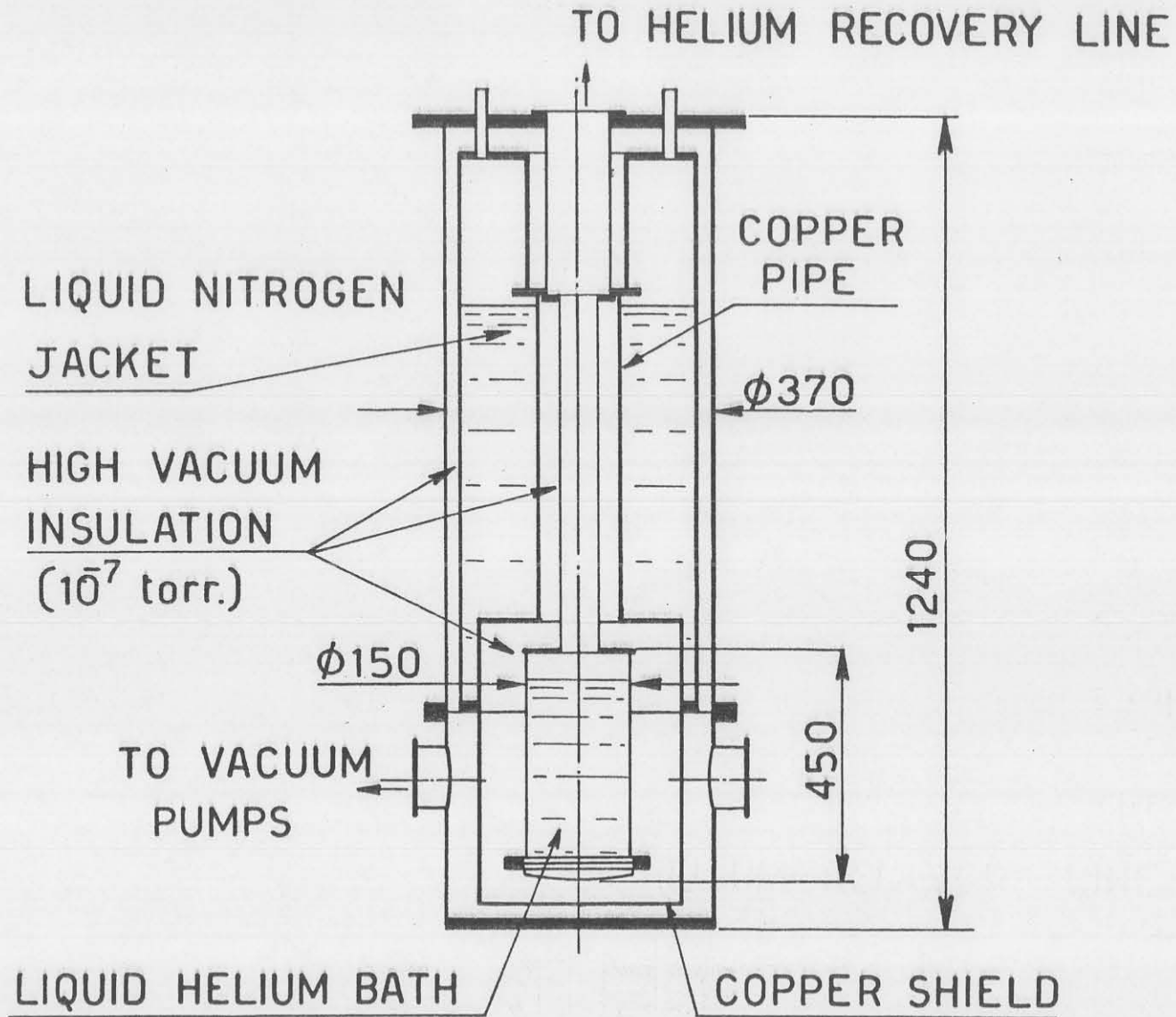
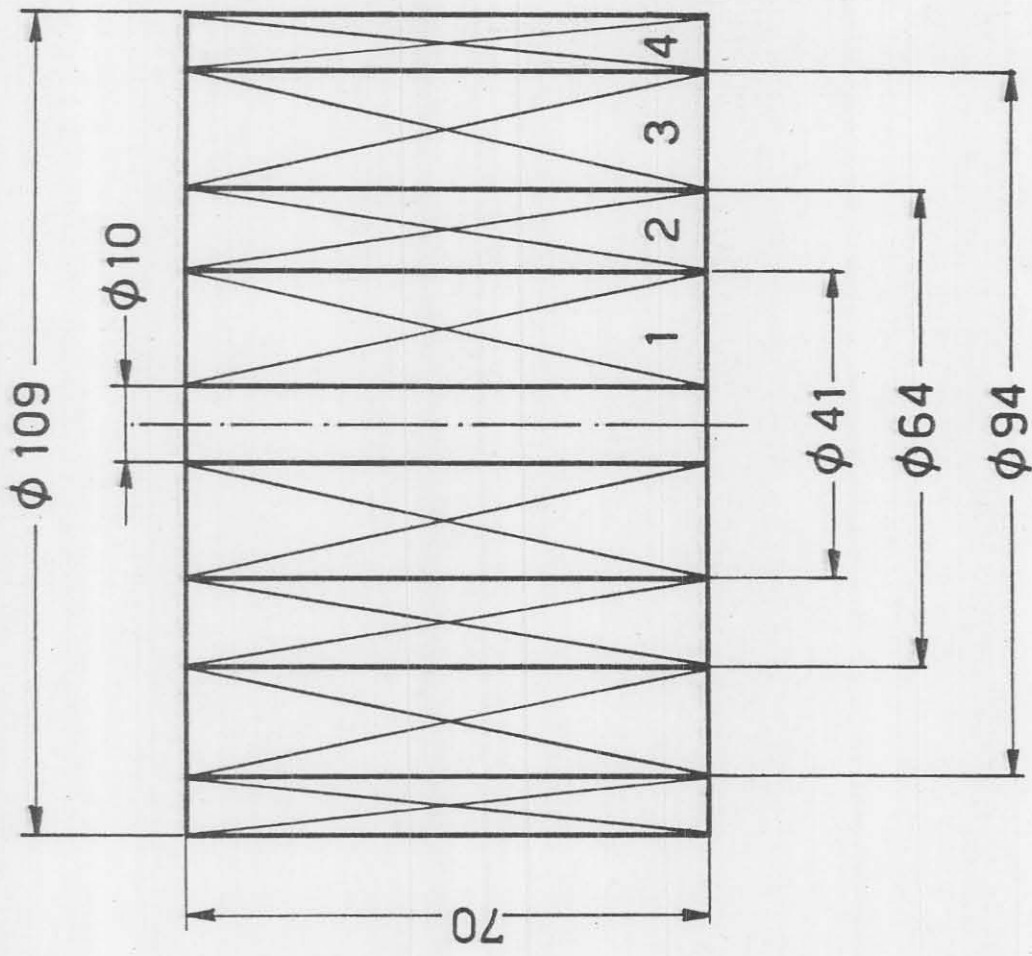

FIG.-3 -



LAYER 1: 10:300 TURNS

- 2: 7600 "
- 3: 9600 "
- 4: 5100 "

Nb-25% Zr NYLON INSULATED

WIRE ($\phi=0.254$ mm)

FIG.-5-

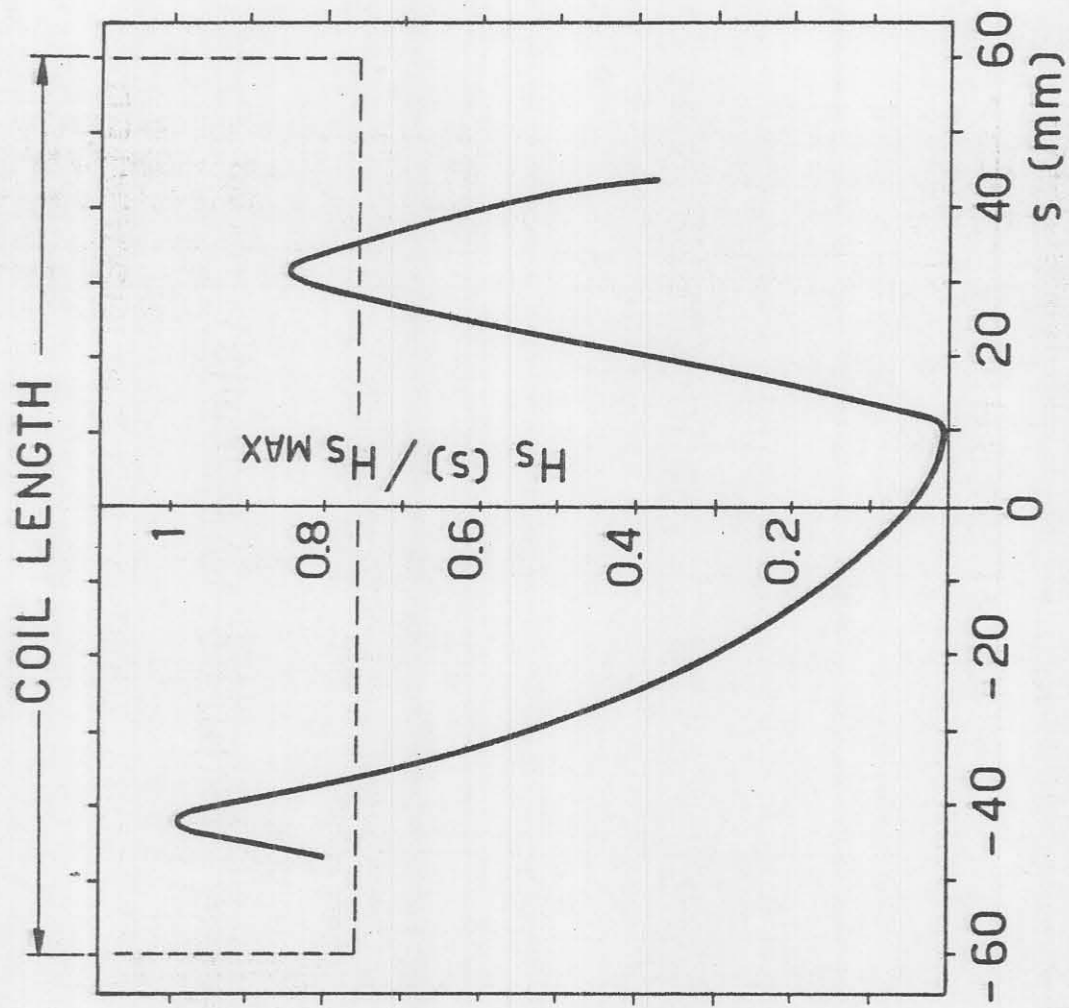

FIG.-6-b)

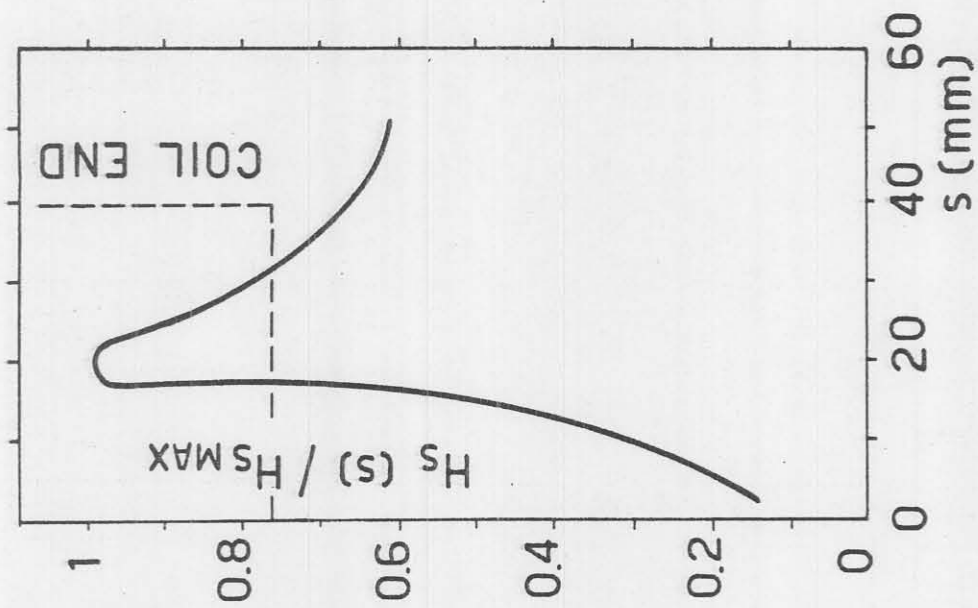

FIG.-6-a)