

Laboratori Nazionali di Frascati

LNF-60/40 (8. 8. 60)

R. Querzoli, G. Salvini, A. Silvermann: THE POLARIZATION OF THE
PROTON FROM THE PROCESS $\gamma + p \rightarrow p + \pi^0$ IN THE REGION OF THE
HIGHER RESONANCES.

Nota interna : n° 50
8 Agosto 1960

R. Querzoli, G. Salvini, A. Silverman: THE POLARIZATION OF
THE PROTON FROM THE PROCESS $\gamma + p \rightarrow p + \pi^0$ IN THE RE
GION OF THE HIGHER RESONANCES.

§ 1 - Introduction

The single photoproduction of pions in the energy interval 500 - 1100 MeV has been measured in the last three years, with several contributes from the electron synchrotron of Caltech, and Cornell University, and only more recently from the Frascati groups. (1) The discovery of other maxima after the well known resonance at 300 MeV has stimulated the investigation on the behaviour of the differential cross section and of the polarization of the recoil nucleon. The polarization is particular interesting in the case of the neutral photoproduction $\gamma + p \rightarrow p + \pi^0$.

We report in the present paper an experiment to measure the polarization of the recoil proton in this reaction.

Generally speaking the interest in the polarization of the recoil proton comes from the following arguments, which hold as long as the process may be described in the general frame of quantum mechanics, with a transition matrix which is a sum of the contributing multipole transitions, each with a total angular momentum, a given parity, and a definite isotopic spin value:

- a) - there is polarization of the recoil proton only when at least two different states are present.
- b) - The polarization may indicate the relative parity of the states: in particular the polarization is absent for the protons emitted at 90° in the center of mass system, if two states are present with the same parity.

...

From a), b) one deduces that the measurements of the polarization at 90° in the center of mass may contribute to find out those ray energies where only one state can describe the pion-nucleon system, and may contribute to determine the relative parity of the interfering states. The interest of the polarization has been recently underlined by Sakuray (2) as a method to establish the parity of the second resonance.

We have measured the polarization of the protons at 90° c.m. in order to get an information which is very useful to establish which multipole transition can describe the photo-production phenomena in the region 500-1000 MeV of the incident γ rays.

The polarization of the protons has been measured until now up to a maximum of 700 MeV by Stein (3).

§ 2 - Experimental disposition

Aim of the present experiment is then the measurement of the polarization of the recoil protons from the reaction

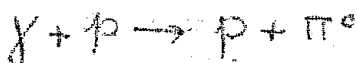

To get the polarization we measure the left to right asymmetry in the scattering of protons from carbon at different angles between 14° and 16° .

The experimental disposition is given in fig. 1. The counters 1, 2 10 are plastic scintillation counters which detect the proton; the Cerenkov counter detects the π^0 meson through its decay γ rays. We indicate by C the carbon scatterer, whose thickness was changed according to the proton energy; Cu are the copper absorbers which define the range of the proton energy.

We were counting at the same time four kinds of coincidences:

(Cer, 1, 2, 3, 4, -5) - L_I ; (Cer, 1, 2, 3, 4, 5, -6) - L_{II}
(Cer, 1, 2, 7, 8, -9) - R_I ; (Cer, 1, 2, 7, 8, 9, -10) - R_{II}

it is therefore possible to measure two different energy intervals of the protons, corresponding to two different energy intervals of the γ 's.

Discrimination of the protons against the pions is guaranteed by the required coincidence with the Cerenkov counter as well as by pulse height discrimination in counters

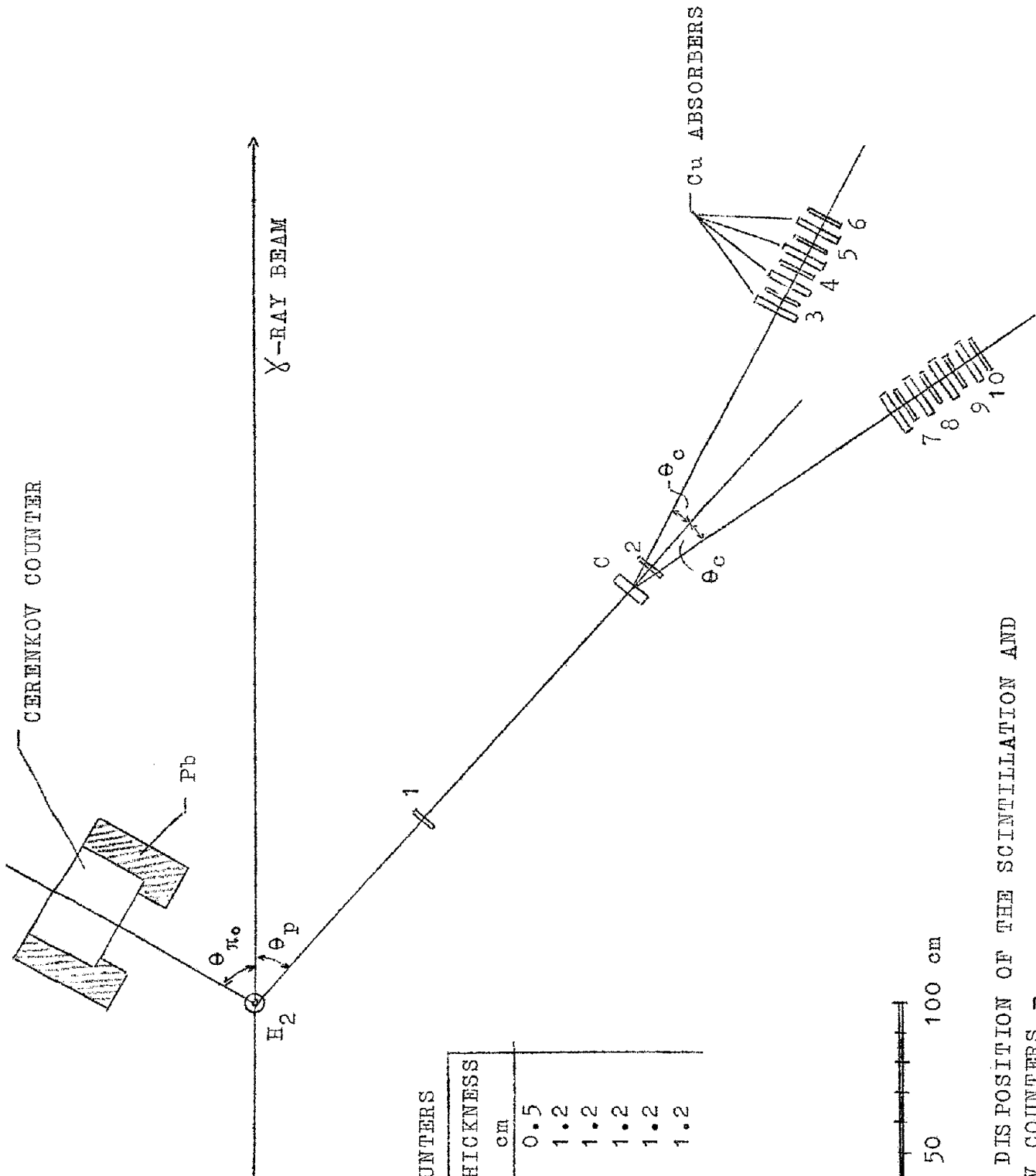

DIMENSIONS OF THE COUNTERS

#	WIDTH cm	HEIGHT cm	THICKNESS cm
1	9	14	0.5
2	10	25	1.2
3-7	12.5	25	1.2
4-8	12.5	25	1.2
5-9	12.5	25	1.2
6-10	12.5	28	1.2

FIG. 1 - GENERAL DISPOSITION OF THE SCINTILLATION AND Cerenkov COUNTERS.-

2, 3, 7.

The block diagram of our electronic is given in fig. 2

By F.C. we indicate fast coincidences, with a resolving time of around 5 ns. The pulses arriving to the discriminators D. are on the contrary rather slow (time around 200 ns) so that it is easy to realize a precise height pulse discrimination. As shown in fig. 2, the anticoincidences $L_I L_{II}$ are obtained as the differences between the coincidences (Cer, 1,2,3,4), (Cer 1,2,3,4,5), (1,2,3,4,5,6) in order to reduce dead time effects. As a check we also register the three coincidences in each telescope.

All the measurements reported in this paper have been taken on the protons emitted at an angle of 42° degrees in the laboratory system which corresponds to an angle close to 90° in the center of mass system for all our energies (see table 1).

The choice of the dimension and the distances of the counters as well as the angle of scattering from the carbon is made on the basis of the measured elastic cross sections and analyzing power of protons in Carbon. In fig. 3 we report the cross section for elastic scattering from carbon for protons of different energies (the incident beam is unpolarized), according to the work of many authors (4-7).

In fig. 4 we report the corresponding analyzing power for the same energies of the protons. We define the analyzing power P_c in the usual way, as the asymmetry :

$$\xi = \frac{\text{Left} - \text{Right}}{\text{Left} + \text{Right}} \quad (1)$$

for an incident beam of polarization + 1.

The choice of the scattering angle and of the dimensions of the hydrogen target and of the counters has to take into account the following features of the proton-carbon interactions:

- The elastic cross section is a steep function of the angle (increasing for smaller angles)
- There is a definite maximum of the analyzing power at rather low values of the elastic cross section.
- The Rutherford diffusion has to be taken into account in the choice of the scattering angle.
- The analysing power of the Carbon decreases with $\cos \varphi$, φ being the angle between the photoproduction plane and the plane of scattering in the carbon.

FIG. 2. BLOCK DIAGRAM OF THE ELECTRONIC FOR THE LEFT CHANNEL.

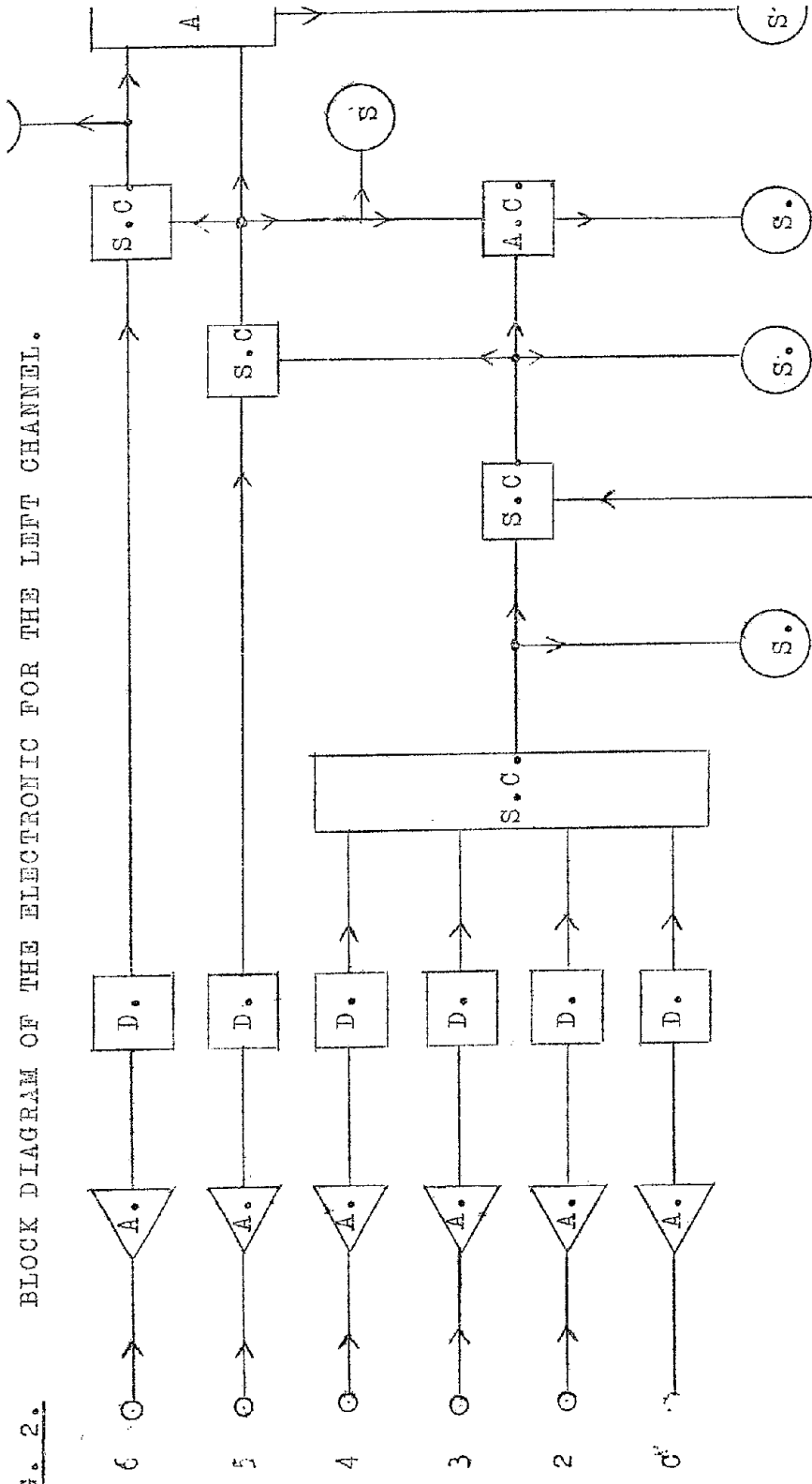

A	AMPLIFIER.
D	DISCRIMINATOR.
S	SCALER.
A.C.	ANTI-COINCIDENCE.
F.A	FAST AMPLIFIER.
F.C	FAST COINCIDENCE $\tau = 5 \text{ nsec}$
S.C	SLOW COINCIDENCE $\tau = 200 \text{ n}$

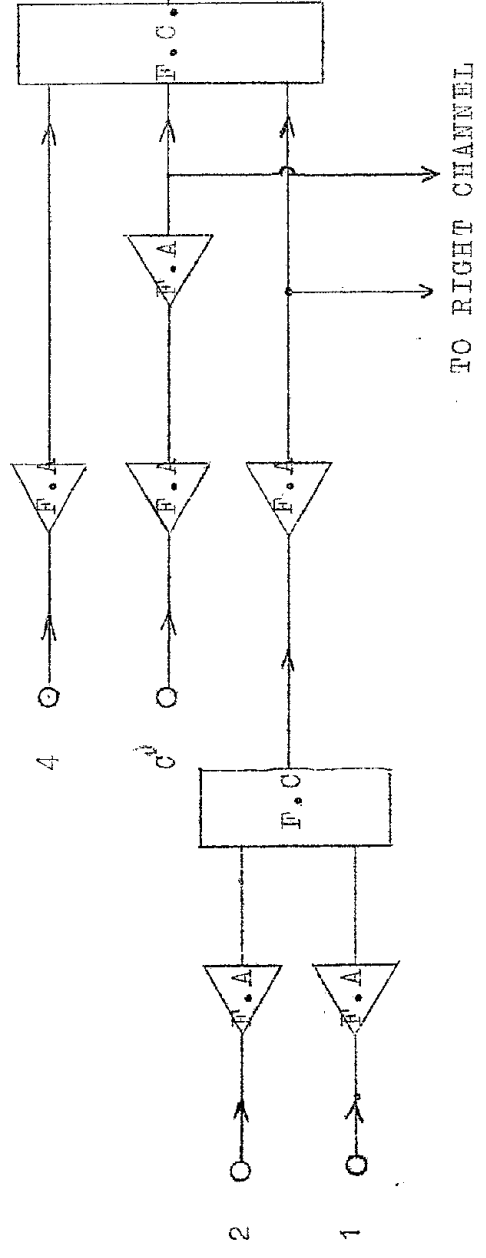

Fig. 5 gives a graph where in the ordinate there is the product of the time t of counting multiplied by ΔP^2 , being ΔP the error in the measurement of the polarization of the proton; in the abscissa there is the angle of scattering of the proton in carbon.

The graph has been drawn for an energy of the proton of 180 MeV. It clearly shows that the minimum time, for a given error ΔP , is displaced toward an angle smaller than the angle corresponding to the maximum value of the analyzing power; this being due to the fast decrease of the scattering cross section versus the scattering angle. The graph of fig. 5 does not take into account the contribution of the rutherford scattering. With the help of graphs of this type the average angle and the horizontal dimensions of the counters have been chosen. The geometrical angular resolution we used is reported in the same fig. 5 at the bottom.

The vertical dimensions of the counters are larger than the horizontal dimensions, but with the general condition that $\cos \varphi \leq 0,8$.

In table 1 are reported the values of the elastic scattering angles Θ we have chosen at different proton energies.

The hydrogen target is similar to the type already in use at Cornell University: the hydrogen container is a cylindrical vessel with a vertical axis. The diameter is 7,4 cm, and it is 8,7 cm high. The wall is a foil of stainless steel plus mylar, with a total thickness per wall of 22 mg/cm². The vessel is contained in a cylindrical stainless steel vacuum chamber; mylar windows (3 mg/cm²) for the γ rays and the protons are prepared in the chamber. Thin aluminium radiation shields are disposed between the vessel and the wall of the chamber. The diameter of our γ ray beam at the target, is 4,5 cm. This dimension is defined by a lead collimator 18 mm in diameter; the collimator is at 2,3 m from the internal target (0,5 mm Ta) and 3,5 m from the H₂ target.

In fig. 6 we give as an example the kinematical situation of our measurements. The rectangles are determined by the thickness of the copper absorbers we have chosen and by the dimensions of the counters.

The three rectangles which have been drawn refer to energies of 560, 700, 800 MeV for the γ ray beam. Fig. 6 makes clear the reason why we preferred to use anticoincidences to define the energy of the protons, rather than limiting this energy by the top of the γ ray beam: in this latter case one would have a proton flux on the carbon which is larger

$(d\sigma)$ mb/sr

- 135 MeV DICKSON, SALTER
- 180 MeV TYREN, MARIS
- ◇ 290 MeV CHAMBERLAIN

FIG. 3 DIFFERENTIAL CROSS SECTION FOR ELASTIC SCATTERING OF PROTONS OF DIFFERENT KINETIC ENERGIES ON CARBON (POLARIZATION ZERO, LEFT - RIGHT)

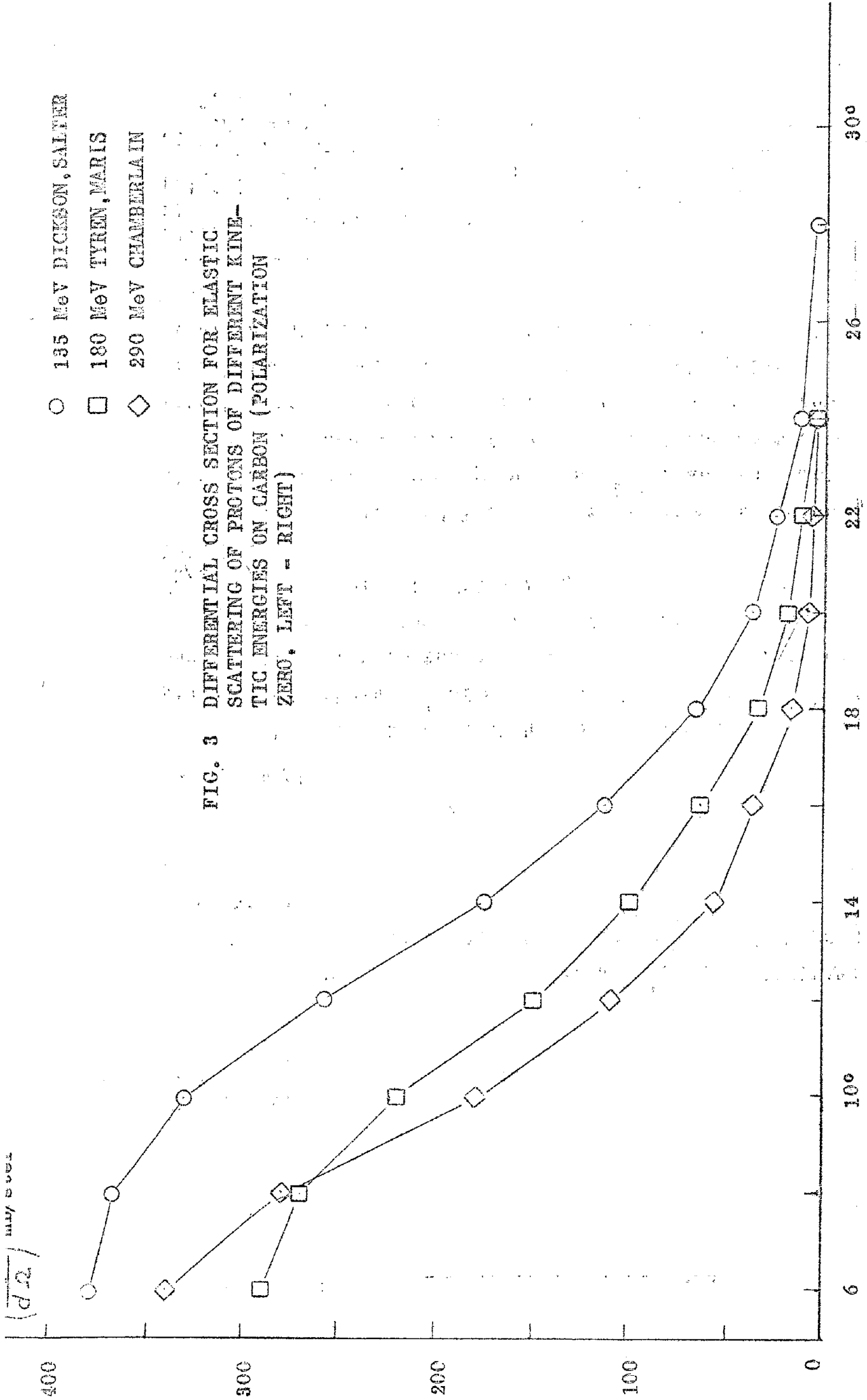

SCATTERING ANGLE OF THE PROTON IN THE LABORATORY

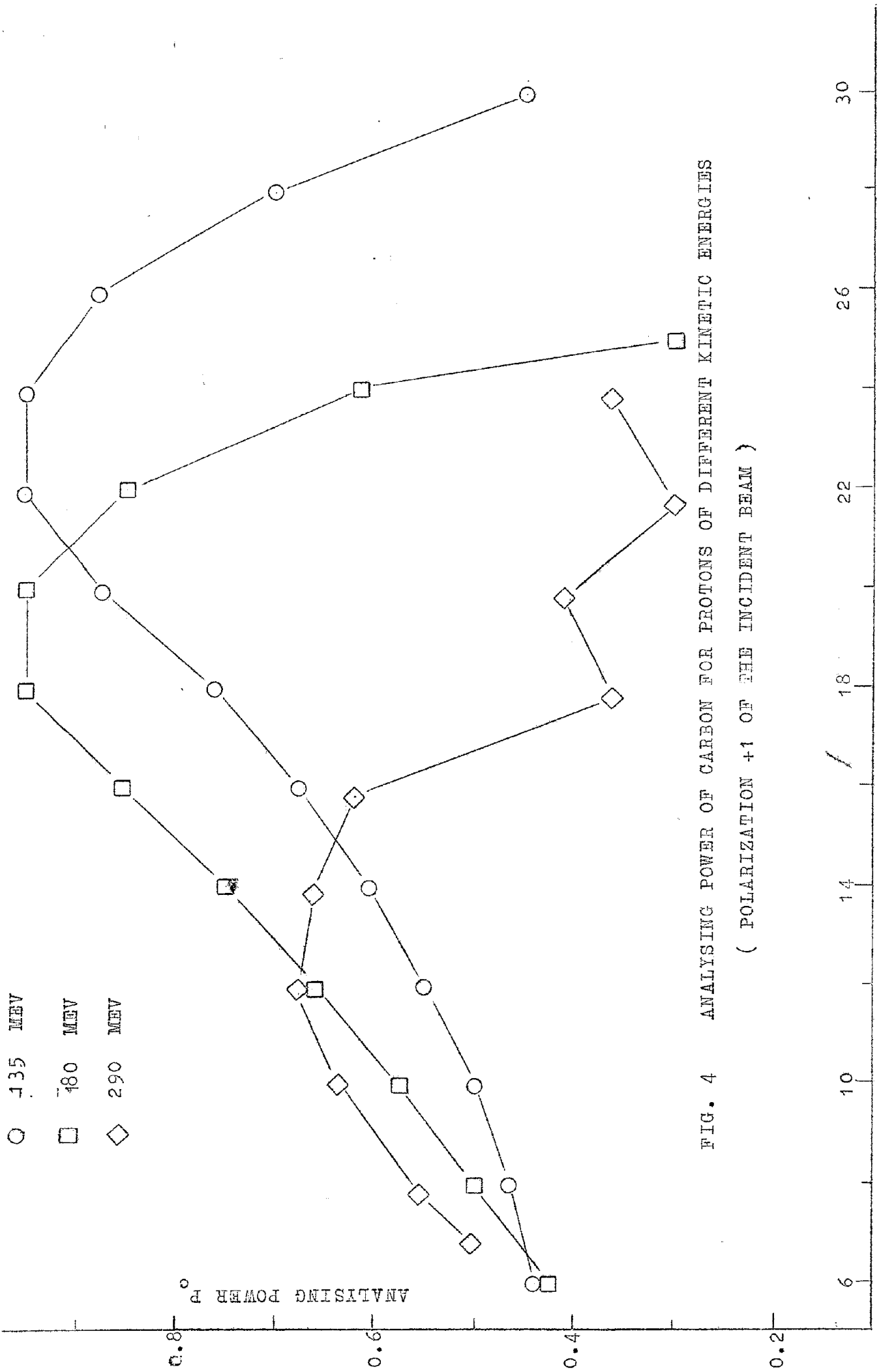
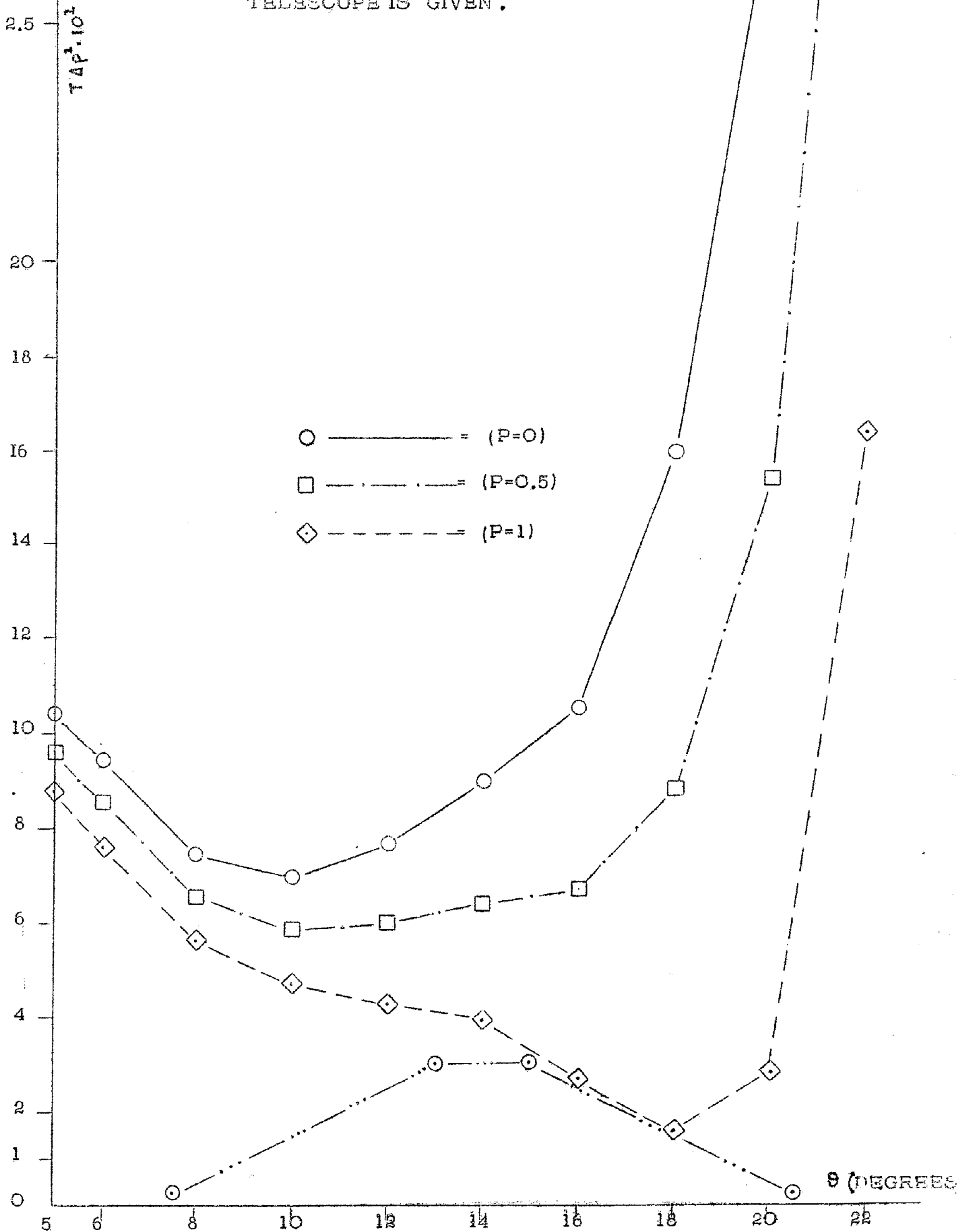

FIG. 4 ANALYSING POWER OF CARBON FOR PROTONS OF DIFFERENT KINETIC ENERGIES
 (POLARIZATION +1 OF THE INCIDENT BEAM)

SCATTERING ANGLE OF THE PROTON IN THE LABORATORY

FIG.5 THE PRODUCT $T\Delta p^2$ VERSUS THE ELASTIC SCATTERING ANGLE IN CARBON OF 180 MEV PROTONS . BELOW THE CURVES THE ANGULAR RESOLUTION OF OUR TELESCOPE IS GIVEN .



at smaller angles: this gives rise to an asymmetry between the two telescopes, even if the laboratory differential cross section for photoproduction does not change with the angle Θ .

The proton flux on the carbon scatterer may differ from point to point: as we explain later, we have measured the differential flux of the protons at each energy, as a function of the angle of emission Θ .

The Cerenkov counter is made with a lead glass cylinder 18 cm thick and with a diameter of 35 cm. Light is collected by three photomultipliers in parallel, type 6364, which are in direct contact with the glass.

In front of the Cerenkov counter is a lead shield which reduces its opening to a diameter of 25 cm. It is possible, because of the rather high energy of our pions, to cut by a discriminator the height of the pulses from the Cerenkov, so that most of the charged pions do not enter the coincidences. This helps to avoid a possible contamination by neutrons in our proton telescopes.

Part of our measurements have been made with a different Cerenkov counter: a cylinder of lucite with a lead converter in front 8 mm thick.

Counter 1 has been added in order to avoid the possibility that a neutron coming from a charged pion photoproduction may arrive to the carbon, produce a proton in a quasi-elastic collision, and be detected as a scattered proton in our coincidences.

The discussion of the results have confirmed to us that the presence of counter number 1 was not strictly necessary.

We have therefore included in our results some measurements which were taken without counter 1 in position.

§ 3- Measurements and controls.

The measurements for each γ ray energy were taken in the following order. First, one of the two telescopes (for instance that at the right) is aligned with the hydrogen target and with counter number 1, and the thresholds of the discriminators of counters 4,5,6 are fixed to a level corresponding to an energy loss of at least 3 MeV in the scintillator. Second, on the basis of a photographic analysis of the height of the pulses, the levels of the discriminators of counters 1,2,3 are fixed, so that they certainly count the protons and only a very small percent of the pions. The further discrimination against the pions is made by the Cerenkov counter.

PROTON KINETIC ENERGY

350

300

250

200

150

FIG. 6 PROTON KINEMATICS IN THE
PROCESS $\gamma + p \rightarrow p + \pi$ AND POSITIONS
OF THE OBSERVED POINTS AT 560,
700, 800 mev (FIRST ENERGY CHAN=
NEL)

$E_{\gamma} = 100$

950

900

850

800

750

700

650

600

550

500

38

39

40

41

42

43

44

45

46

PROTON LAB. ANGLE

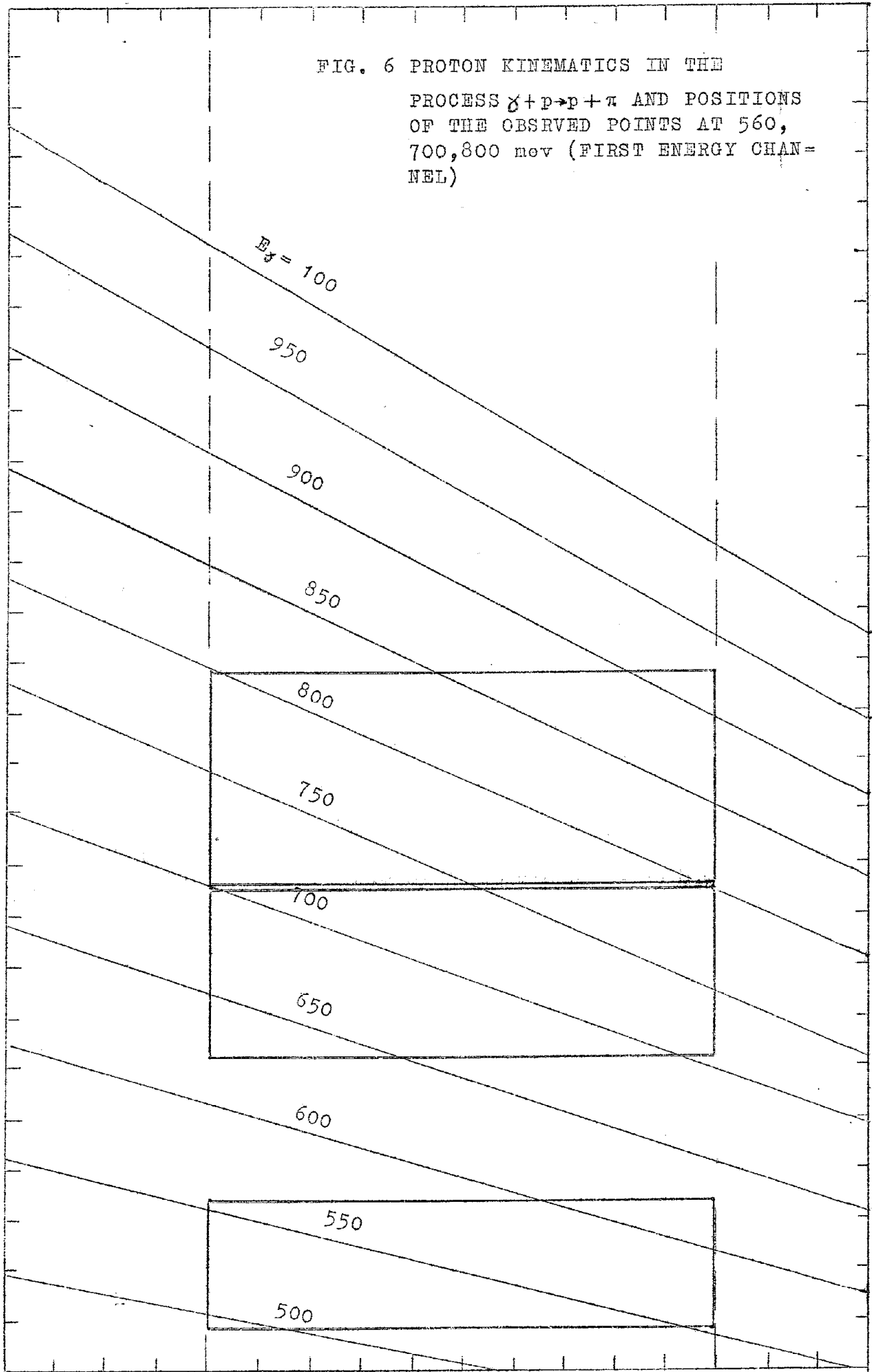

Third, the threshold of the Cerenkov counter is fixed to a value, that makes the counting rate quite independent from its voltage.

Similar preliminary measurements are made on the telescope at the left, and by alternatively aligning the right and the left telescope we verify that the counting rate is the same within statistic (usually within 4%). After those controls have been made the two telescopes are finally set at the chosen scattering angle and the measurements starts. Measurements with and without liquid hydrogen in the target, and with delays on the Cerenkov counter, on the counters 1 and 2, on the counters 4 and 8 are taken in order to measure accidentals. Every three to four hours each telescope is aligned to check that the counting rates are equal.

At each chosen γ ray energy the distribution of the proton flux on the carbon scatterer was made: this measurement is necessary to deduce the polarization from the measured left to right ratio.

To do this, a counter (number 11 which is 2,5 cm large and 25 cm high) is placed just in front of the carbon, in line with the hydrogen target and one of the two telescopes; thus we measure the coincidences between counter 11 and the telescope plus Cerenkov for three different positions of counter 11 in front of the carbon. This gives the change of the proton flux with the angle Θ of the recoils protons emitted from the hydrogen; in this way the possible different efficiency of the Cerenkov at different angles is automatically taken into account. The results of these measurements are reported for a few energies in fig. 7.

One of the main difficulties in our measurements is due to the fast dependence of the proton-carbon elastic cross section on the angle; as a consequence any local difference in efficiency of our large counters may give rise to an apparent asymmetry. To be safe from this effect some further controls were made:

- a) Measurements have been taken of the protons scattered from the carbon at different angles between 0° and 16° , to the left and to the right, at energies for which the proton flux arriving to the carbon was rather uniform. In this way we could make sure that the angle zero coincides with the symmetry axis of our system, for those small angles for which the polarization effect is negligible, and that the two telescopes are

FIG. 7 DIFFERENTIAL PROTON FLUX AT DIFFERENT POSITIONS OF COUNTER 1†

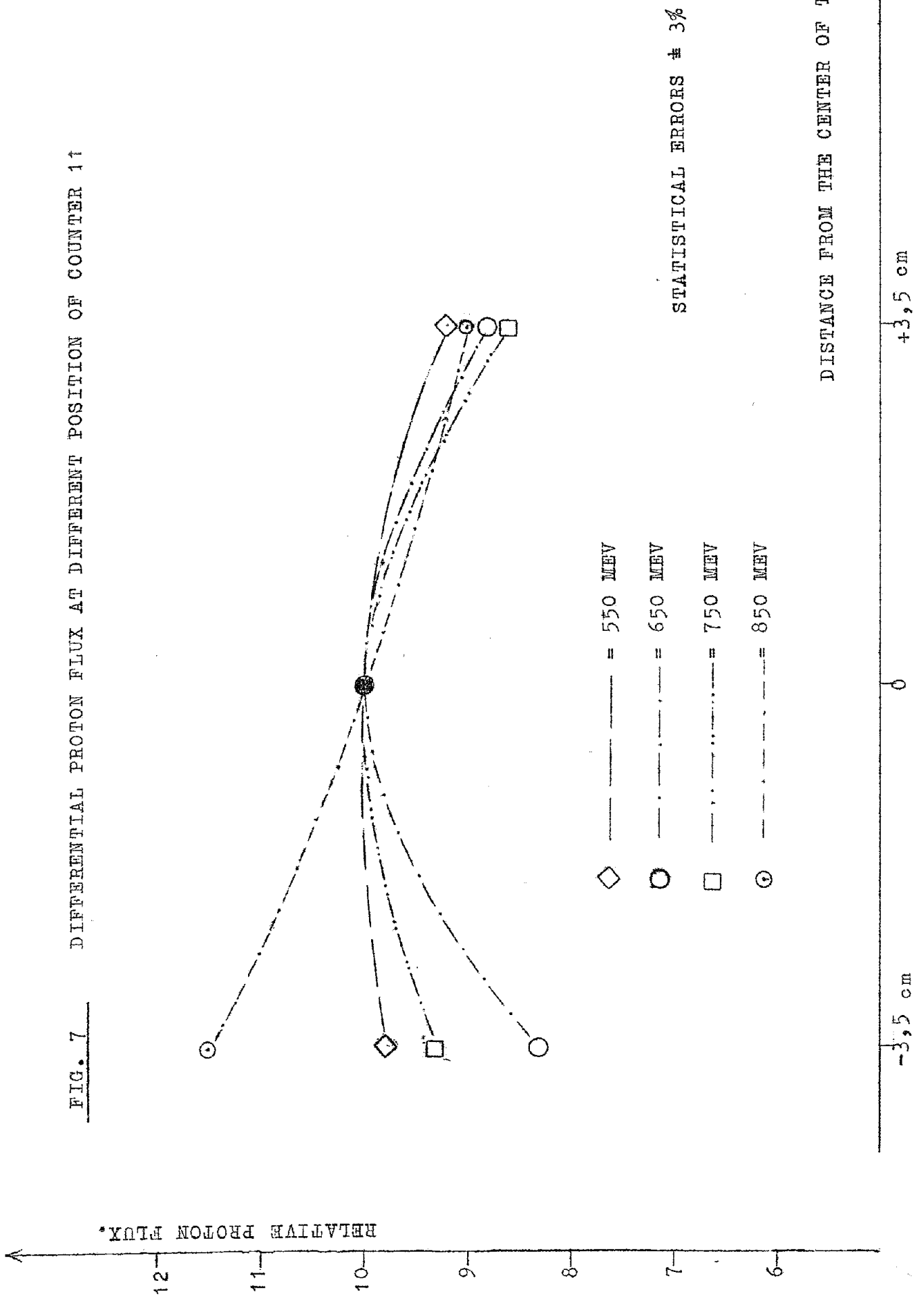

really equivalent also where the proton intensity changes very fast with the angle.

- b) Measurements have been made with the carbon substituted by an equivalent amount of lead, and placing the telescopes at an gles of four to six degrees. Considering the large contribute of the Rutherford scattering and the lower analyzing power of the lead, we should expect equal counting for the two telescopes. The good results of these control measurements strongly contribute to increase our confidence in our results.

§ 4- Results.

Our results are reported in tables I, II. Table I refers to the high energy channels R_I and L_I , and table II reports the results from the low energy channels R_{II} and L_{II} . E_Y is the average energy of the photons producing the protons, E_m is the maximum energy of the γ rays spectrum; ΔE_Y is the energy interval of the photons which contains 75% of the counted protons. Θ_{pcm} is the average angle of the emitted protons in the center of mass.

T is the energy interval of the protons. C is the thickness of the scattering carbon. Θ_c is the average scattering angle of the protons in carbon. Column 8 specifies if the counter one is in position or not. Columns 9 and 10 give the total number of protons scattered to the left and to the right, not yet corrected for accidentals and background. Columns 11 and 12 give the intensity of the protons scattered to the right and to the left respectively, per 10^{13} equivalent quanta, corrected for accidentals and background. In column 11 the ratio is given between the right and the left intensity, and in column 12 the asymmetry is given, defined as

$$\xi = \left(\frac{L - R}{L + R} \right)_{unc.}$$

The results of columns 11, 12, 13, 14 are already corrected for empty hydrogen target and for accidentals, but they have not been corrected yet for the contribute of the inelastic collision. This contribute is calculated in § 5. When the contribute of the inelastic events is subtracted, we finally obtain the correct value ξ of the asymmetry. This value is given in

...

Table I, (II). Columns meaning: 1: central energy of the γ 's; 2: energy of the synchrotron; 3: energy width; 4: proton C.M. angle; 5: kinetic energy of the proton; 6: Carbon thickness; 7: Carbon scattering angle; 8: counter 1 present or not; 9 (10); total number of proton in the left (right) telescope(not yet corrected for accidentals and background); 11 (12): frequency of the left (Right) telescope; 13: ratio right to left; 14: asymmetry (R/L-1); 15: the same corrected for inelastic scattering.

1	2	3	4	5	6	7	8	9	10
E_γ	E_m	ΔE_γ	E_{pcm}	T	C (g/cm ²)	θ_c	#1	Left	Right
560	650	70	90.7 \pm 5.2	129-155	3.7	16.5°	yes	230	365
700	830	95	91.4 \pm 5.2	180-216	8.08	14°	no	194	398
							yes	124	251
750	870	110	91.7 \pm 5.2	195-238	8.08	14°	no	161	284
800	930	118	92.2 \pm 5.2	214-258	8.08	14°	yes	216	392
850	990	130	92.5 \pm 5.2	236-276	8.08	14°	no	139	234

	11	12	13	14	15
	Left	Right	R/L unc	- Σ unc	- Σ
560	7.6 \pm 0.50	11.4 \pm 0.8	1.5 \pm 0.14	0.20 \pm 0.07	0.25 \pm 0.09
700	16.9 \pm 1.4	32.4 \pm 2.5	1.92 \pm .22	0.33 \pm .07	0.42 \pm .10
	19.0 \pm 1.7	38.4 \pm 2.4	2.02 \pm .22		
750	18.8 \pm 1.5	29.4 \pm 2.1	1.69 \pm .19	0.26 \pm .09	0.30 \pm .12
800	10.7 \pm 1.1	20.0 \pm 1.0	1.87 \pm .21	.30 \pm .09	0.37 \pm .13
850	7.6 \pm 0.8	12.9 \pm 1.0	1.7 \pm .22	.26 \pm .10	0.32 \pm .14

Table II.

1	2	3	4	5	6	7	8	9	10	11	12	13	14	15
475	650	75	90.7 \pm 5.2	93-129	3.7	16.5°	yes	1368	1424	42.5 \pm 1.8	43.9 \pm 1.6	1.03 \pm .06	0 \pm 0.03	—
610	830	84	90.9 \pm 5.2	144-180	8.08	14°	no	527	749	40.1 \pm 4.4	62.7 \pm 3	1.56 \pm .19	0.25 \pm 0.07	0.42 \pm 0.18
							yes	194	325	26.1 \pm 3.3	47.9 \pm 3.2	1.84 \pm .28		
650	870	90	91.1 \pm 5.2	162-195	8.08	14°	no	284	476	28.8 \pm 2.1	47.5 \pm 2.6	1.65 \pm .15	0.25 \pm 0.07	0.41 \pm 0.17
700	930	92	91.4 \pm 5.2	180-214	8.08	14°	yes	355	666	18.1 \pm 1.4	35.2 \pm 1.4	1.95 \pm .17	0.32 \pm 0.08	0.50 \pm 0.19
750	990	110	91.7 \pm 5.2	192-236	8.08	14°	no	478	754	26.0 \pm 1.5	40.0 \pm 1.7	1.52 \pm .11	0.21 \pm 0.05	0.31 \pm 0.1

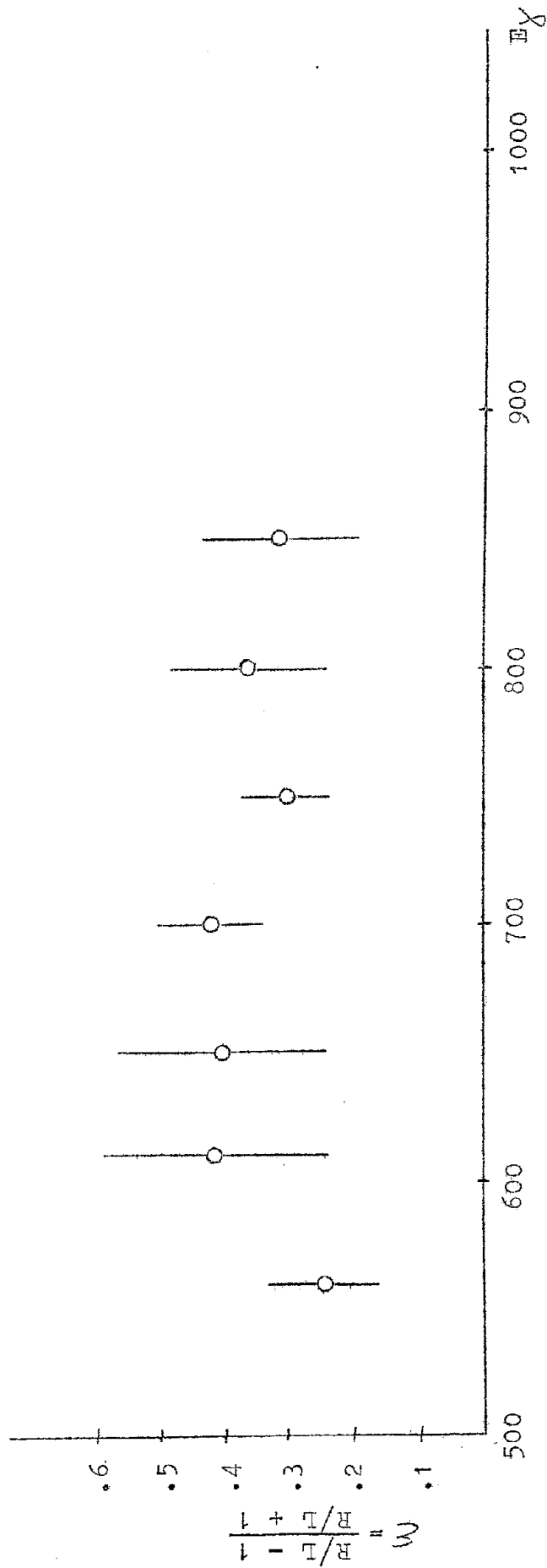

FIG. 2 -- THE ASIMMETRY $\frac{R}{L}$ VERSUS THE ENERGY OF THE PHOTONS (THE INTENSITY IS ALWAYS LOWER AT THE TELESCOPE CLOSER TO THE γ -RAY BEAM).--

in column 15.

During the measurements the average intensity of our collimated γ rays beam was of the order of $2,5 \cdot 10^{10}$ equivalent quanta per minute.

§ 5 - Analysis of the data - corrections.

In order to get the value of the polarization P from the measured left to right asymmetry, one must introduce a number of corrections. We give a list of those we took into consideration. The correction e) is the most important of the group.

- a) Empty target corrections and accidentals.
- b) Unwanted detection of other processes than the single neutral pion photoproduction.
- c) Interactions of the recoil protons in the copper absorbers.
- d) Different proton flux at different points in the carbon, that is in different points in counter number 2.
- e) Inelastic collisions of the protons on carbon. The protons emitted in the photoproduction process which initially have an energy higher than the energy defined in the two channels of our telescopes, may undergo in the carbon an inelastic collision which reduces their energy, and may therefore enter one of the two proton channels. The left to right asymmetry of the protons in these inelastic collisions is definitely smaller than in the elastic ones; as a consequence the inelastic processes, if not subtracted, have a tendency to reduce the total analysing power of the Carbon.

We describe in the following the method we used to estimate the corrections, when we decided we had to take them into account.

Estimate of correction a). The large intensity of our machine makes the quality of our electronics quite important. With our fast coincidences, and by properly clipping the Cerenkov and the other counters we succeeded to reduce the accidentals to about 10%. The empty target events were about 5%. These spurious events were immediately subtracted from our counting rates.

Estimate of corrections b), c). We did not introduce any correction for these effects. In fact many checks made it clear that we were really counting single π_0 events: the excitation curve of our protons, the size of the pulses in our counters, the resulting value of the absolute cross section, etc. The analysis of the possible kinematical conditions, together with any reasonable assumption on the differential cross section, brought us to the conclusion that the contribute in our measu-

ments of the double production of pions may be disregarded. We also did not introduce any correction for the interactions of the protons in the copper absorbers: this effect is symmetric in the two telescopes, and only may slightly change the definition in energy of our channels.

Estimate of correction d). The differential flux of the protons in the Carbon has been measured by the 2,5 cm counter as described in § 3. The correction for this lack of symmetry is taken into account when we deduce the polarization of the recoil protons with the Montecarlo method (see § 6).

Estimate of correction e). All our information on the quality of the carbon as an analyzer for measuring the polarization of the protons comes to us from other experiments, in particular from the synrocyclotron experiments (4-7). These experiments give us the left to right asymmetry and the differential cross section in the elastic collisions of protons on carbon at different energies. It is necessary, to use these results, to subtract from the elastic events those which are due to the inelastic collisions in Carbon, for which the cross section and the left to right asymmetry is unfortunately not as well known. After this subtraction has been done, we can make the estimate of the analyzing power of our system in respect of the protons which have been elastically scattered in our telescopes and which have entered our channels.

The correction may in principle be applied on the following lines. Call $\left(\frac{d^2\sigma}{d\alpha dT}\right)_m$ the differential cross-section for an inelastic collision of a proton on carbon, when it loses an energy T and is scattered at an angle α ; call E the energy of the incident proton. Call $\frac{d\sigma}{d\alpha}$ the differential cross section for elastic collisions of protons on Carbon. Each one of our telescopes detects protons of a given $\Delta E = E_2 - E_1$ energy interval (actually there are, as we said in § 2, two energy channels per telescope, and our calculation has been made for each of them).

Call $N(E) dE$ the number of protons of energy E-dE emitted from the hydrogen and arriving to the Carbon. With this definitions, the number N_{el} of protons elastically scattered at the angle α when the proton flux arrives to the carbon is

$$(2) \quad N_{el} = n_c \Delta\Omega \int_{E_1}^{E_2} \frac{d\sigma}{d\alpha} N(E) dE$$

$\Delta\Omega$ being the solid angle of our telescopes, and n_c the number of carbon nuclei per square centimeter.

The number N_{inel} of protons inelastically scattered is:

$$(3) N_{inel} = n_c \Delta \Omega \left[\int_{E_2}^{E_{max}} N(E) dE \left(\frac{d^2\sigma}{d\alpha dT} \right)_m \frac{E-E_1}{E-E_2} dT + \int_{E_1}^{E_2} N(E) dE \left(\frac{d^2\sigma}{d\alpha dT} \right)_m \frac{E-E_1}{0} dT \right]$$

where E_{max} is the maximum energy of the protons for the given maximum energy of the beam.

Should the value of $\left(\frac{d^2\sigma}{d\alpha dT} \right)_m$ be assumed to be independent of T in our energy interval $(E - E_1) \rightarrow (E - E_2)$, then the ratio of the inelastic collision to the elastic ones may be written as:

$$(4) \frac{N_{in}}{N_{el}} = \frac{(E_2 - E_1) \int_{E_2}^{E_{max}} \left(\frac{d^2\sigma}{d\alpha dT} \right)_m N(E) dE + \int_{E_1}^{E_2} (E - E_1) \left(\frac{d^2\sigma}{d\alpha dT} \right)_m N(E) dE}{\int_{E_1}^{E_2} \frac{d\sigma}{d\alpha} N(E) dE}$$

The integrals contain the proton spectrum $N(E)dE$, which can be expressed by the differential cross section in the laboratory system for photoproduction, $\frac{dS}{d\theta}$, the efficiency C of the Cerenkov counter and the derivative $\frac{dE_x}{dE}$ of the energy of the producing photon versus the proton energy E at our fixed laboratory angle.

If we disregard the contribute of the inelastic collisions inside the channel, that is the second integral in the numerator of (4), formula (4) becomes:

$$(5) \frac{N_{in}}{N_{el}} = (E_2 - E_1) \frac{\int_{E_2}^{E_{max}} \left(\frac{d^2\sigma}{d\alpha dT} \right)_m \frac{C}{E_x} \frac{dS}{d\theta} \frac{dE_x}{dE} dE}{\int_{E_1}^{E_2} \frac{d\sigma}{d\alpha} \frac{C}{E_x} \frac{dS}{d\theta} \frac{dE_x}{dE} dE}$$

where θ is the angle of emission of the proton of energy E from the hydrogen target.

The quantity C is a function of E , and has been calculated by for our geometry, while $\frac{dS}{d\theta}$ is known from previous

experiments. (4)

The ratio (5) may be therefore calculated provided that the functions $\left(\frac{d^2\sigma}{d\alpha dT}\right)_m$, $\frac{dS}{d\alpha}$ are known. It is just the limited knowledge of $\left(\frac{d^2\sigma}{d\alpha dT}\right)_m$, that makes somewhat uncertain the estimate of (5).

The value of $\left(\frac{d^2\sigma}{d\alpha dT}\right)_m$ has been measured by Tyron and Maris (7) in the angular region of $5^\circ - 49^\circ$ (which includes the values interesting for our telescopes), at a kinetic energy of the protons of 185 MeV, and in the energy interval $0 < T < 35$ MeV.

This nice piece of information is unfortunately limited to the energy $E = 185$ MeV. The value of $\left(\frac{d^2\sigma}{d\alpha dT}\right)_m$ exhibits a few peaks, clearly connected to some known carbon levels, for $0 < T < 15$ MeV, and varies in the limits $0.5 < \frac{d^2\sigma}{d\alpha dT} < 1.5$ mbarns per steradian per MeV for values of T between 15 and 35 MeV.

The only informations at energies $E > 200$ MeV has been indirectly deduced from some absorption measurements of Chamberlain and cow. (5) We have interpreted their results as an indication that $\frac{d^2\sigma}{d\alpha dT} \approx .7$ millibarns/Ster MeV at $E = 300$ MeV, and $20 < T < 150$ MeV.

The function $\left(\frac{d^2\sigma}{d\alpha dT}\right)_m$ and the polarization of the protons may be considered rather well known in the region of the low energy levels of the carbon.

Having at disposal this limited amount of information, we calculated our correction for the inelastic events using formula (5). The function $\left(\frac{d^2\sigma}{d\alpha dT}\right)_m$ has been assumed to be of the form:

$$\left(\frac{d^2\sigma}{d\alpha dT}\right)_m = \frac{552 - E}{338} \frac{\text{mbarn}}{\text{ster. MeV}}$$

and valid in the energy interval $130 - 300$ MeV. (this value is in agreement with the results at 185 and 300 MeV).

As we said, in formula (5) the contribute of the integral

$$\int_{E_1}^{E_2} (E - E_1) \left(\frac{d^2\sigma}{d\alpha dT}\right)_m N(E) dE$$

given in (4) has been disregarded. This corresponds to include among the elastic collisions the quasi elastic ones, for which $\bar{T} \leq (E_2 - E_1)$. The average value of

T is in this case $T \leq \frac{E_2 - E_1}{3 \left(\frac{d\sigma^2}{dT d\Omega} \right)_0}$, the equality being valid for a constant value of $\left(\frac{d\sigma^2}{dT d\Omega} \right)_0$, which is not true, being the cross section generally larger for small values of T. IN our case we have $T \leq 10$ MeV, and one does not introduces an appreciable error assuming for these excitation energies a polarization comparable with that from the elastic collisions.

Let's call A the ratio N_{inel}/N_{el} . Once the value of A is known, it is possible to get the correct value of the asymmetry ξ :

$$\xi = (1+A) \xi_{unc.}$$

In tables I and II the values of ξ_{unc} and the values of ξ (columns 14 and 15) for different proton energies are given.

An alternative way is offered to us in order to estimate the contribute of the inelastic collisions, or at least to verify the validity of our corrections. As explained in § 2 we have the possibility to measure protons of a given energy interval $E_2 - E_1$ in channel I or in channel II. The left to right asymmetry of the protons of a given energy has to be the same, independently from the channel where they are revealed, but for the contribute of the inelastic collisions, wich are relatively more in the second channel and have a tendency to reduce the asymmetry ξ_{unc} in this channel. Once the corrections for the inelastic collisions have been made with the method we outlined above, we shall have the same value of ξ , inside the statistical errors, for protons of the same energy interval, independently from their channel. The check is quite efficient, due to the different distance of the two channels from the top energy of the protons.

The results of this check confirm our method, In Table III and in Fig. 9 we added togheter the asymmetries resulting from the first as well as from the second channel.

6 - The computation of the polarization P from the corrected asymmetry. The Montecarlo method.

Let's call $P_c(\alpha)$ the analysing power of the carbon at the angle α , that is the asymmetry $\xi = \frac{L}{L+R} = \frac{R}{L+R}$ for an incident proton beam of polarization + 1. Let's call P the polarization of the recoil protons we are measuring. As well known, the relation holds:

$$(6) \quad \xi = P_c(\alpha) P$$

Relation (6) is exactly valid at a definite angle α .

In an extended telescope a range of angles α is interested and the value of P_c is an average obtained from a proper integration on all possible angles α . The integration has been performed on the following lines.

Let's consider as an "elementary" telescope, that element of our telescope which detects a proton emitted from a given point of the H_2 target and scattered in a given point of the carbon with given angles α and φ (φ is the angle among the photoproduction plane and the plane determined by the proton lines of flight before and after the collision in the carbon, that is the scattering plane: α is the angle among these two lines of flight).

We have divided the counters M,N (see fig. 9) in $4 \times 8 = 32$ elements, and in the calculation each element is replaced by its center. We have calculated the probability $F_{L,R}$ for having a proton emitted from the H_2 target, scattered in the carbon, and reaching a given element i of the counter at the left or at the right. This implies integration on all the possible positions in the H_2 target and in the carbon. The H_2 target may be approximated by a short segment along the x rays direction.

By this approximations the probability for the proton to get the i th element of the counter is given by an expression of the type

$$(7) \quad (F_i)_{L,R} = \iint K \left[\left(\frac{d\sigma}{d\Omega} \right)_{L,R} \right] d\xi dS ; \quad K \frac{d\sigma}{d\Omega}(\alpha, \varphi) = I_i$$

where the factor K was introduced to take into account the difference in proton flux on the carbon from point to point, dS represents the elementary surface surrounding the point on the carbon where the scattering takes place, ξ is the coordinate on the hydrogen target. The integral (7) has been computed by the Montecarlo method.

The function $\frac{d\sigma}{d\Omega}$ is the differential elastic cross section in carbon, α which is different at the left and at the right for polarized protons; it is given by

$$\left(\frac{d\sigma}{d\Omega} \right)_L = \left(\frac{d\sigma}{d\Omega} \right)_{AV} \left[1 + P P_c(\alpha) \cos \varphi \right] \text{ at the left}$$

$$\left(\frac{d\sigma}{d\Omega} \right)_R = \left(\frac{d\sigma}{d\Omega} \right)_{AV} \left[1 - P P_c(\alpha) \cos \varphi \right] \text{ at the right}$$

...

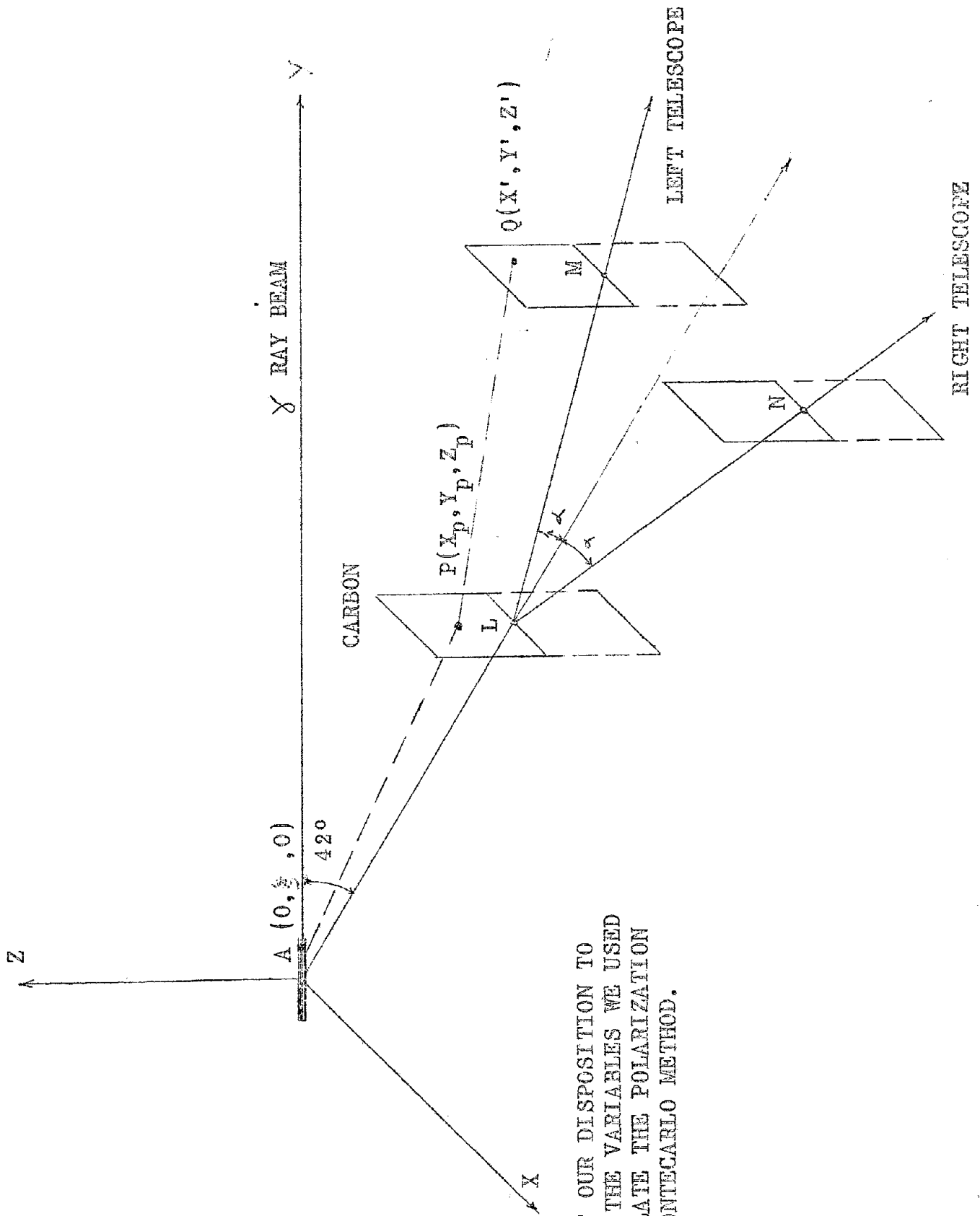

FIG. 9 - A VIEW OF OUR DISPOSITION TO INDICATE THE VARIABLES WE USED TO CALCULATE THE POLARIZATION BY THE MONTECARLO METHOD.

The total flux of protons at the left and at the right is obtained by adding each contribute F_i as given in (7):

$$F_L = \sum_{i=1}^{32} (F_i)_L \quad F_R = \sum_{i=1}^{32} (F_i)_R$$

The final asymmetry is given by :

$$\xi = \frac{F_L - F_R}{F_L + F_R}$$

The relation between the asymmetry ξ and the proton polarization is linear, and in order to have it, it is enough to estimate the value of ξ for $P = -1$ and for $P = 0$. If the proton flux on the carbon is uniform, it evidently has to be $\xi = 0$ for $P = 0$. In the other cases an approximate calculation of ξ per $P = 0$ was made, by dividing the carbon in three parts, and using the experimental results on the proto, flux in carbon we already reported.

For $P = -1$ the integral (7) has been computed by the Finac electronic computer of the Istituto Nazionale del Calcolo, using the following method. One point (ξ, S) within the limits of the integral was extracted at random, and the value of the function $I_i(\xi, S)$, as given in (7) was calculated. After a sufficient number of random extractions N , we can evaluate the mean value of I_i :

$$\bar{I}_i = \frac{\sum_{e=1}^N I_{i,e}(\xi, S)}{N}$$

The product $\bar{I}_i \times V_{\xi, S}$, $V_{\xi, S}$ being the volume within which we integrate, gives the Montecarlo value of the integral given in (7).

§ 7- The sign and the value of the polarization

We have found a Right/Left ratio larger than one in all our measurements, and we made our measurements at the right of the γ ray beam (see fig. 1). The intensity of the protons scattered from the carbon is therefore lower at the telescope which is closer to the γ ray beam. By knowing the ana-

TABLE III -- The asymmetry to be expected according to the Montecarlo method for $P=-1$ and for $P=0$, the experimental value of ξ (col. 4) and the corresponding value of the polarization of the recoil proton (col. 5)

(1)	(2)	(3)	(4)	(5)
E	$\xi_c (P=-1)$	$\xi_c (P=0)$	ξ	P
560	0.64	0.01	-0.25 ± 0.09	-0.4 ± 0.14
610			-0.42 ± 0.18	-0.63 ± 0.23
650	0.69	0	-0.41 ± 0.17	-0.6 ± 0.25
700			-0.43 ± 0.09	-0.57 ± 0.12
750	0.82	0	-0.31 ± 0.07	-0.38 ± 0.09
800			-0.37 ± 0.13	-0.5 ± 0.17
850	0.68	-0.04	-0.32 ± 0.14	-0.5 ± 0.22

FIG. 10 THE POLARIZATION P OF THE RECOIL PROTON AT
90° C.M. VERSUS THE GAMMA RAY ENERGY

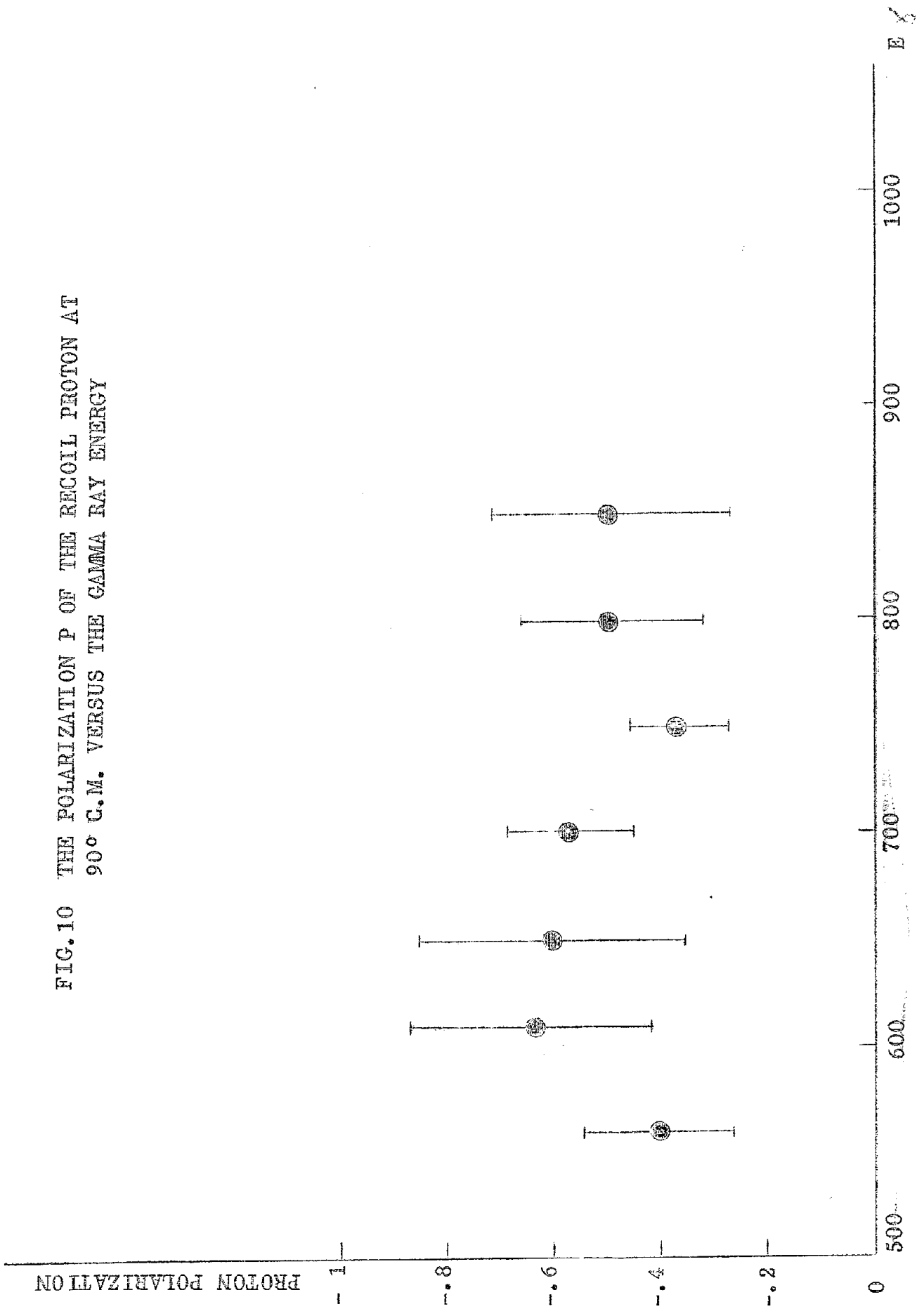

lyzing power of the carbon, we can say that most of our protons emitted from the hydrogen target have the spin down. If we define the sign of the polarization by the vector (\vec{P}) as we show in formula (8), then the sign of our polarization results to be negative.

In table III we give the results on the polarization: The energy of the γ ray beam is given in column (1); the asymmetry ξ as resulting from the Montecarlo method when the incident protons have polarization $P = -1$ is given in column (2); the same for $P=0$ in column (3); column (4) reports the experimental value we found for the asymmetry (which is negative according to our definition), and finally we give in column (5) the value we found of the polarization of the recoil protons.

The value of the polarization P as a function of the γ ray energy is also given in fig. 10.

We remark that our results at 700 MeV and 550 MeV are in agreement with the results of Stein (3).

Discussion of our results.

A general discussion of the experimental results in photoproduction has been recently made by Peierls (8), and we shall refer to his work.

In particular this author has given a general table of the angular distributions and polarizations in photoproduction, and we will make use of his results.

His assignments have been done on the basis of π^+ and π^0 photoproduction, and of the polarization up to 700 MeV; his attribution of the states is reported in the table IV. We shall see that our results agree with his general assignments, but differ in the possible estimate of the relative amplitudes of the levels.

The more interesting characteristic of our results is that the polarization remains rather high from 550 MeV up to 850 MeV, as if at each energy two or more interfering states, with a resulting polarization of negative sign, were present. In particular no minimum of the polarization appears around 700 MeV.

We must therefore look for those states who can describe the already known results of the differential cross se-

Table IV. Quantum number describing the three photoproduction resonances. l = multipole order
 Y = total angular momentum; w = parity
 T = isotopic spin, $-K^+$ and K^0 sign of the multipole amplitudes for π^+ and π^0 photoproduction, respectively.

Level	l	Y	w	K^+	K^0	T
A	1	3/2	+	-	-	3/2
B	1	3/2	-	+	-	1/2
C	2	5/2	+	+	-	1/2

ctions for neutral and positive pions, and who can produce a polarization of negative sign in the notation of Boierls and rather constant in our range of energies.

a) Assignement of the levels on the basis of the sign of the polarization.

The results on the differential cross section and on the polarization at 700 MeV or less are in qualitative agreement with the assignements of table IV. In the iphotesis that onlly the three levels A,B,C are present, the expression of the polarization becomes:

$$(8) \quad P(\theta) = \frac{1}{\frac{d\sigma}{d\Omega}} \left\{ -4AB \sin(\delta_A - \delta_B) - 5\sqrt{3} \times AC \sin(\delta_A - \delta_C) + \right. \\ \left. + \sqrt{3} BC (x^2 - 2) \sin(\delta_B - \delta_C) \right\} \sin \theta (\vec{n})$$

with $x = \cos \theta$

(\vec{n}) is a unit vector normal to the production plane, which we define as:

$$(\vec{n}) = \frac{(\vec{k} \wedge \vec{q})}{|\vec{k} \wedge \vec{q}|}, \quad \text{being } \vec{k}, \vec{q} \quad \text{the momenta of the}$$

incoming photon and the outgoing pion in the c.m. system.

$\frac{d\sigma}{d\Omega}$ is the photoproduction cross section for π^0 production; it is given by

$$(9) \quad \frac{d\sigma}{d\Omega} \sim \frac{1}{2} A^2 (5 - 3x^2) + B^2 \left(\frac{5}{2} - \frac{3}{2} x^2 \right) + \frac{3}{2} C^2 (1 + 6x^2 - 5x^4) - \\ - 2AB \times \cos(\delta_A - \delta_B) + \sqrt{3} AC (1 - 3x^2) \cos(\delta_A - \delta_C) + \\ + \sqrt{3} BC (6x - 4x^3) \cos(\delta_B - \delta_C)$$

$A e^{i\delta_A}, B e^{i\delta_B}, C e^{i\delta_C}$ are the amplitudes of the level pro-

ducing the first, second, third resonance respectively A, B, C may be positive or negative and we restrict therefore the phase δ to lie between 0 and π .

Our experimental results refer to $X=0$. In this case the AC interference term is zero in (8). The two remaining terms AB, BC both give a negative polarization. This comes from the fact (see table IV) that A, B, C are of the same sign and that the phase difference only varies between 0 and π . This sign of the polarization both at the left and the right of the second resonance agrees with our experimental results.

b) On the amplitude of the levels at different energies.

The analysis of Polaris has been done under the hypothesis that polarization is small or absent above 700 MeV. This was indicated by some preliminary measurements quoted by him, which does not seem to agree with our present results. In fact (see figure 10) we find a definite negative polarization and this result may somewhat change the discussions as developed before.

It is reasonable to assume that the amplitude of C is negligible below 700 MeV. In fact there is no evidence of appreciable terms x^4 in the angular distributions below 800 MeV, this implying that at least at 700 MeV $C^2 \ll A^2 + B^2$. In this case the high polarization we observe at 700, 750 MeV must be due, according to 7), to the interference AB: that is, the amplitude A of the first resonance extends beyond 700 MeV. When the energy increases the contribute of the AB interference decreases, but at the same time the interference BC comes out and this can explain our experimental result that the polarization remains rather constant up to 850 MeV. Our statistical uncertainties do not allow to establish if there is a real minimum around 750 MeV.

Just to fix our ideas we tried to calculate the polarization on the following hypothesis: amplitude A vanishes only after 800 MeV; amplitude B has a maximum at 700 MeV and an extension corresponding to a width of the second resonance of about 120 MeV; the amplitude C starts from 700 MeV and has a maximum at 1100 MeV. In these hypothesis and with a reasonable assumptions on the phase we found values of polarization at different energies which are consistent with our results.

While we believe the qualitative indications that we derived from our results, we do not consider convenient to try to get more quantitative results, because we reali-

se that, with the present large statistical errors in the measurements of the polarization and of the differential cross section, is not yet possible to obtain in an unambiguous way the value of the amplitudes of the multipole states also supposing that only states A, B, C are contributing in this range of energies. It is certain that more refined work remains to be done in this energy interval. In particular for the polarization, it may be interesting to examine the function $P(\theta)$ at other angles than $\theta = 90^\circ$.

In conclusion, our results agree with the hypothesis that:

- 1) The three states A, B, C corresponding to the first, second third resonance, are sufficient to explain the single π^0 photoproduction in the range of energies 500-900 MeV.
- 2) The three states A, B, C have multipole order 1, total angular momentum J, parity w, sign, isotopic spin, as assigned in table IV.
- 3) The resonance A extends its amplitude rather beyond 700 MeV, (for instance up to 800 MeV).
- 4) The resonance C has an amplitude of the same order as B, and starts to be important from 750 MeV on.

BIBLIOGRAPHY

- (1) J.I. Vette Phys. Rev. III - 622 - 1958
R.M. Worlock - Phys. Rev. 117- 537 - 1960
M. Heimberg, W. M. McClelland, F. Turkot, W.M Woodward
R.R. Wilson and D.M. Zipoy-Phys. Rev. 110-1208-1958
I. W. Do Wire, H.E. Jakson and R. Littauer Phys. Rev.
110-1208-1958
P.C. Stein and K.C. Rogers Phys. Rev. 110-1209-1958
F.P. Dixon and R.L. Walker Phys. Rev. Letters 1-142-1958
- (2) J.J. Sakurai - Phys. Rev. Lett. 1-258-1958
- (3) P.C. Stein - Phys. Rev. Letters 2-473-1959
- (4) J.M. Dickson and D.C. Salter - Nuovo Cim. VI -235-1957
Alphonse, Johansson, Tibell - Nucl. Phys. 3 - 185-1957
- (5) O. Chamberlain, E. Segrè, R.D. Tripp, C. Wiegand and
T. Ypsilantis - Phys. Rev. 102-1659-1956
- (6) E.M. Hafner- Phys. Rev. 111-297-1958
K. Gotow NYO - 2352 - University of Rochester 1959

- (7) H. Tyren and A.J. Maris - Nucl. Phys. 3-52-1957 and
Nucl. Phys. 4-662-1957
- (8) R.F. Peierls Phys. Rev. 118-325 (1960)

RIASSUNTO.- E' stata misurata la polarizzazione dei protoni di rinculo nella reazione $\gamma + p \rightarrow p + \pi^0$, usando il fascio γ dell'elettrosincrotrone di Frascati; le misure sono eseguite ad un angolo corrispondente a 90° nel sistema del baricentro, nell'intervallo di energia dei γ di 500-900 MeV. Si è usata una tecnica di contatori; la polarizzazione dei protoni è ricavata dalla asimmetria nella diffusione elastica, a sinistra e a destra, dei protoni contro carbonio.

I risultati sperimentali sono dati in tab. III e in fig. 10. E' stata trovata polarizzazione diversa da zero, sempre dello stesso segno, a tutte le energie misurate e precisamente: $P = -0,4 \pm 0,14$ a 560 MeV; $P = -0,63 \pm 0,23$ a 610 MeV; $P = -0,6 \pm 0,25$ a 650 MeV; $P = -0,57 \pm 0,12$ a 700 MeV; $P = -0,38 \pm 0,09$ a 750 MeV; $P = -0,5 \pm 0,17$ a 800 MeV; $P = -0,5 \pm 0,22$ a 850 MeV.

La discussione di questi risultati sperimentali, insieme a quelli sulle distribuzioni angolari, porta alla conclusione che essi sono in accordo con l'ipotesi che la seconda risonanza sia una transizione ($E_1, d^{3/2}$) e la terza sia una transizione ($E_2, f^{5/2}$).