

Laboratori Nazionali di Frascati

LNF-58/12 (Sett. 1958)

M. Ageno et al. : THE 1100 MeV ELECTROSYNCHROTRON OF THE
NATIONAL LABORATORIES OF FRASCATI. PRESENT STATE OF WORK
AND SCIENTIFIC PROGRAM.

Relazione n° : G 25
Settembre 1958

The 1100 MeV Electronsynchrotron
of the National Laboratories of Frascati.
Present state of work and Scientific Program

by

M.Ageno, - A.Alberigi, - F.Amman, - C.Bernardini, -
G. Corazza, - G.Diambrini, - G.Ghigo, - E.Persico, -
M.Puglisi, - I.F.Quercia, - R.Querzoli, - G.Sacerdoti, -
G.Salvini, - G. Sanna, - G. Scaccia Scarafoni, - P.G.Sona, -
R.Toschi, - A.Turrin.

(A report of the Frascati Staff presented by G. Salvini at
the 2nd World Conference - Geneva, September 1958)

=====

§ 1. - Introduction.

The Electronsynchrotron herebelow described will
have a max. energy of 1100 MeV.

Project and design belong to the 'Comitato Na-
zionale per le Ricerche Nucleari'. The program started
according to a proposal of the President of the 'Istitu-
to Nazionale di Fisica Nucleare'.

The present work for a specific design started
at the beginning of 1955. Part of 1953-54 had been dedi-
cated to decide between weak and strong focusing, and
to reach a compromise between max. energy, scientific
interest, and available funds.

In addition to the description of the machine,
the following pages contain also a few remarks on the
Scientific Program.

MAGNET	R.F. AND ELECTRONICS	VACUUM	INJECTOR	THEORETICAL GROUP	LIQUID H ₂	BUILDING AND GENERAL FACILITIES	ADMINISTRATION
AMMAN BOLOGNA DIAMBRINI GHIGO MURTAS SACERDOTI SALVINI SANNA TOSCHI	ALBERIGI MASSAROTTI PUGLISI QUERCIA	CORAZZA SIRCANA	AGENO BIZZARRI CORTELLESSA QUERZOLI	PERSICO BERNARDINI SONA TURRIN	CARERI MONETI MONTELATI	CERCHIA LADU SCACCIA	AGOSTINI

FIG. 1 - LIST OF THE PERSONS EMBARGED OF THE PROJECT AND THE CONSTRUCTION.

§ 2. - General characteristics of our machine.

The following fundamental data are referred to a max. energy of 1000 MeV, although the machine is supposed to reach at least 1100 MeV (1) :

- Final energy	:	1000 MeV
- Max. field	:	B = 9260 Gauss
- Radius of the main orbit	:	R = 360 cm
- Number of straight sections	:	= 4
- Length of straight sections	:	L = 120,6 cm
- Field index	:	n = 0,61
- Injection energy (total)	:	$E_i = 2,5$ MeV
- Height of the gap	:	= 8,6 cm
- Width of the polar faces	:	=22,7 cm
- Injector	:	Cockroft-Walton in pressurized tank
- Repetition rate	:	20 pulses per sec.

The Synchrotron building and the pertaining Laboratories are located in Frascati, some 20 km away from Rome. Fig. 2 and Fig. 3 represent two partial views of the Laboratories.-

§ 3. - The Magnet and the Magnetic measurements.

a) The magnet is C-shaped, with the doughnut outside. One of its sections is shown in Fig. 4, while Fig. 5 represents a top view of the whole ring.

The magnet has four straight sections, and

(1) - Report G. 19 of the Frascati Laboratories.

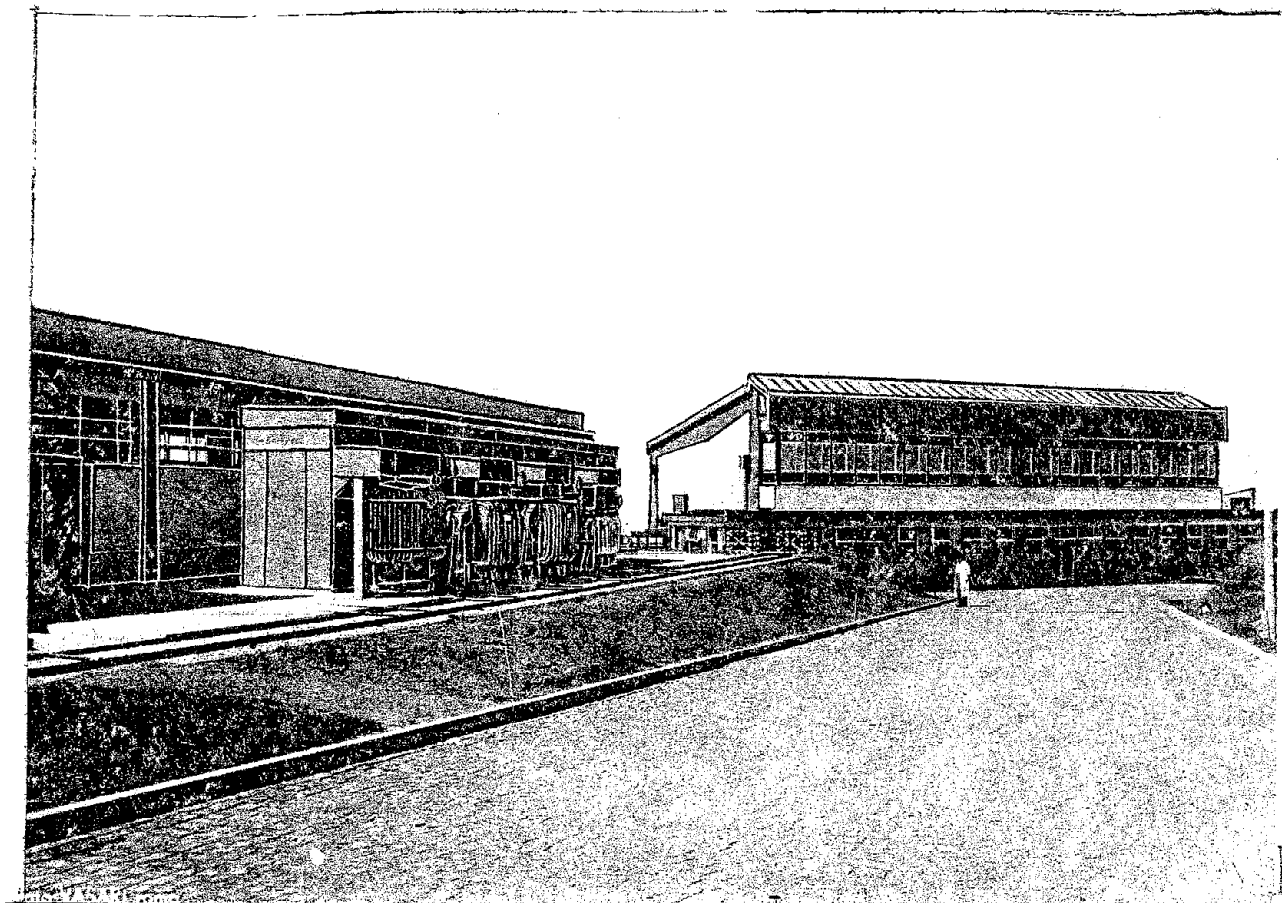

Fig. 2 - Front view of the Synchrotron Building

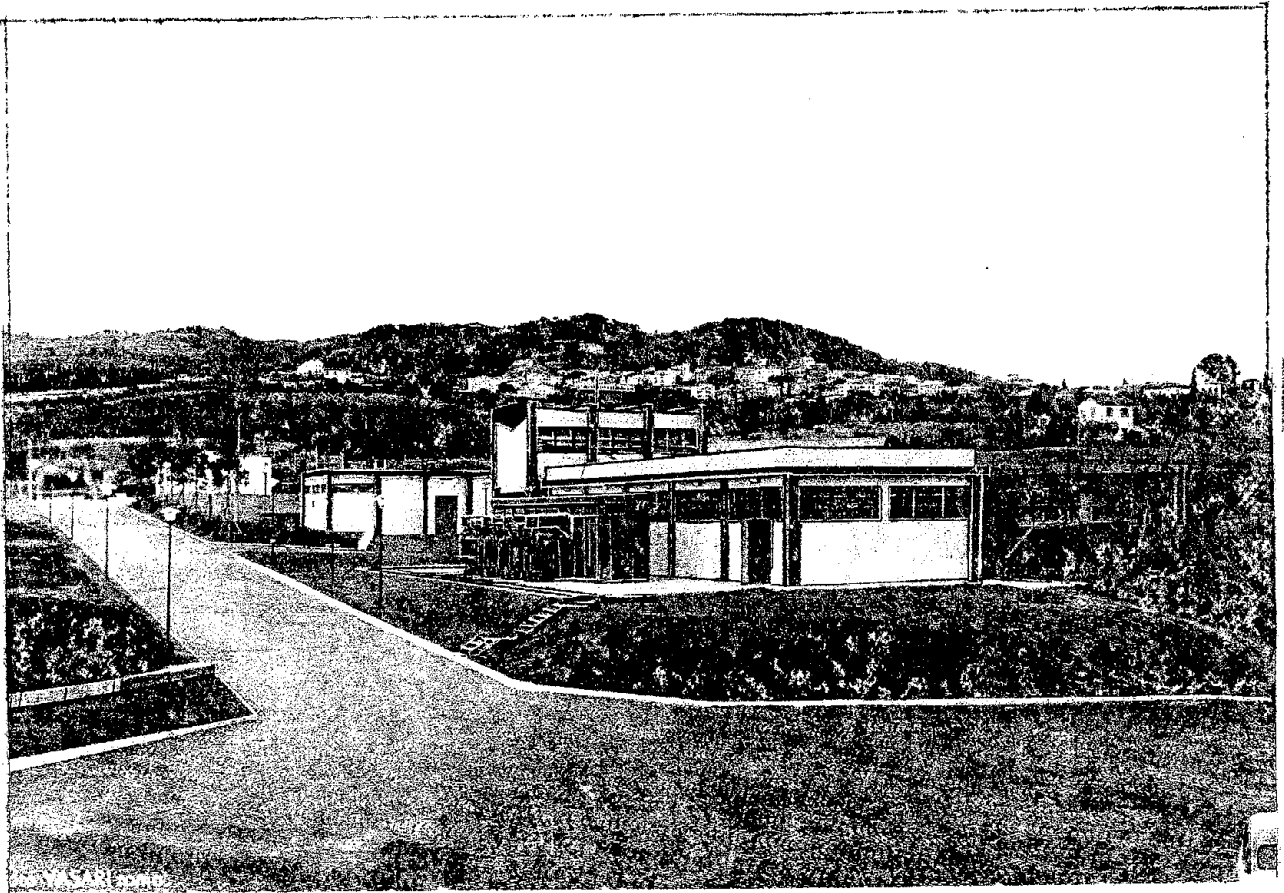

Fig. 3 - Electric Power Supply. In the background: Frascati

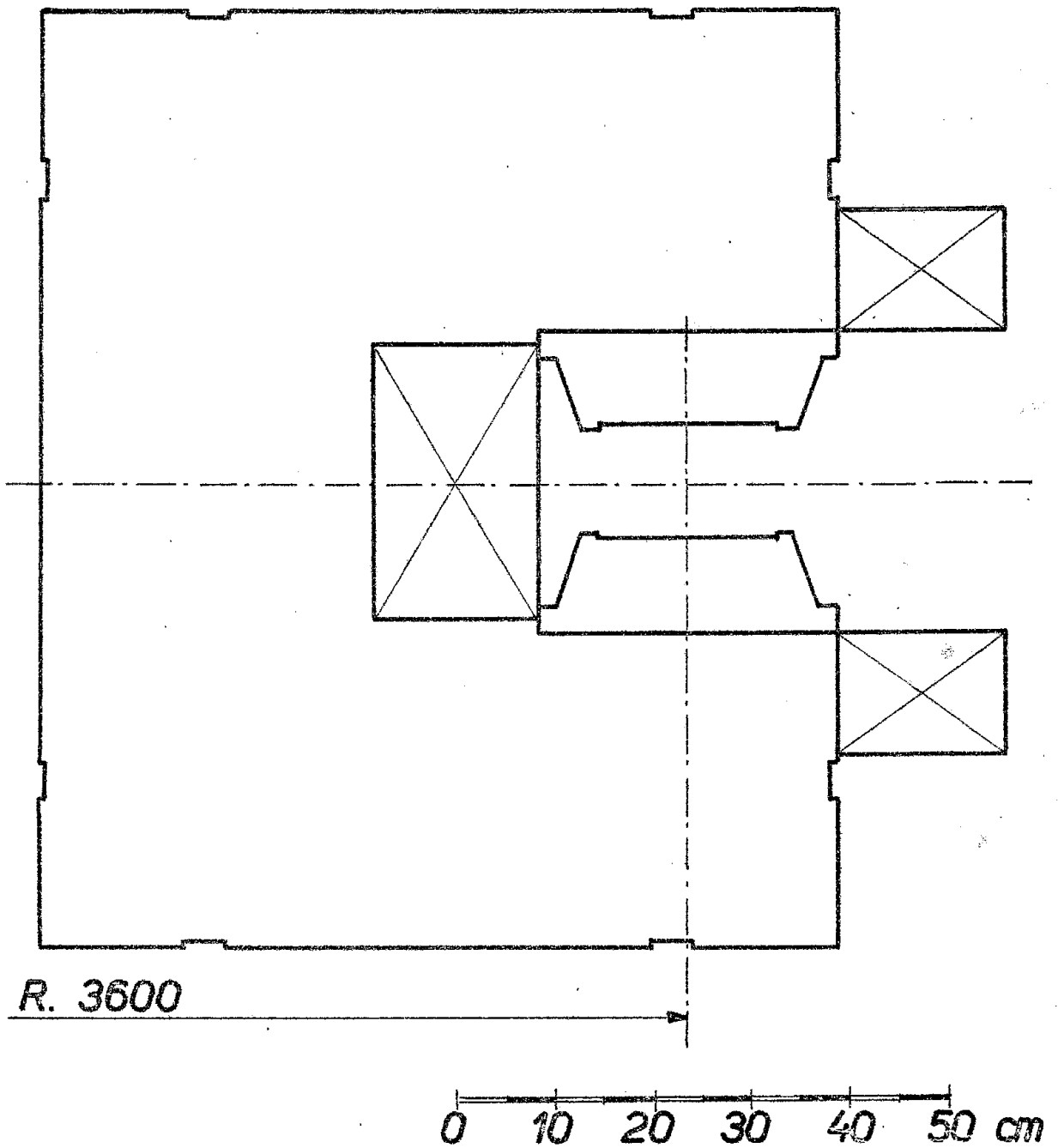

FIG.4 - RADIAL SECTION OF THE MAGNET

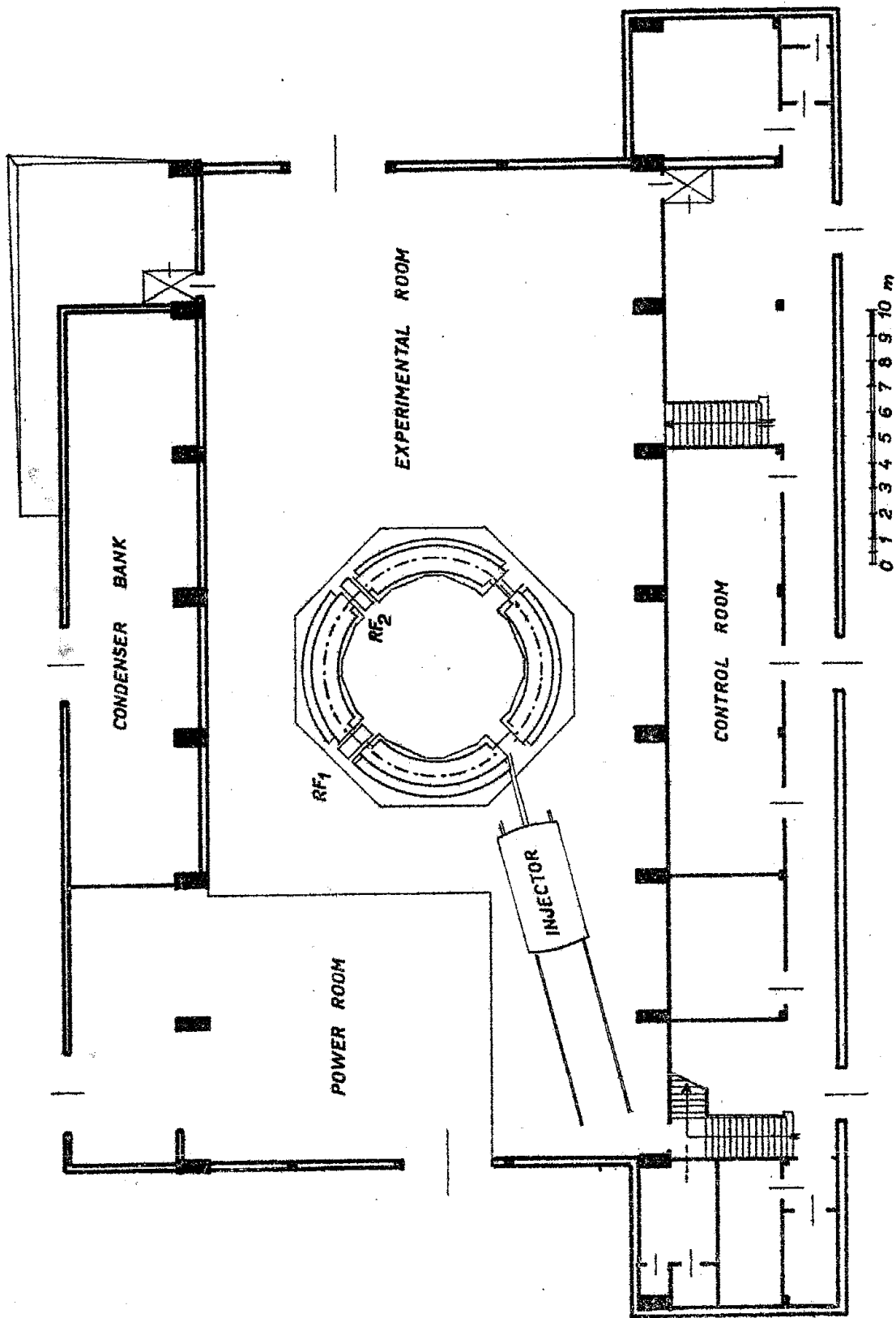

FIG. 5 - TOP VIEW OF THE ELECTRONSYNCHROTRON AND THE EXPERIMENTAL ROOM

the laminations are glued together with araldite.

Structural details of the magnet are shown in Fig. 6,7,8,9, the main data being as follows :

- Type : C-structure with outside doughnut
- Poles : removable, and fastened to the C-wings
- Height of the gap : = 8,6 cm
- Azimuthal structure : = 4 quadrants
- Iron weight (approx.) : = $9,3 \times 10^4$ kg
- Number of turns per quadrant : = 12
- Type of iron laminations: ARMCO DI-MAX 19, 0,35 mm thick = 9260 Gauss at 1000 MeV
- Max. average induction in the iron (approx.) : = 14000 Gauss at 1000 MeV
- Magnet inductance : = $18,5 \times 10^{-3}$ henry
- Max. energy in the air : = $2,65 \times 10^5$ Joule

The magnet of the Electronsynchrotron is excited with alternate current (a.c.), partially biased with d.c. Fig. 10 shows the excitation scheme. Main data of this excitation are as follows :

- Frequency of the power supply (= repetition frequency) : = 20 periods per sec.
- Stability in current, voltage, frequency : = 0,1 % (2)
- Condenser bank kVA rating at 50 c/s in parallel to the magnet : = 10560 kVA

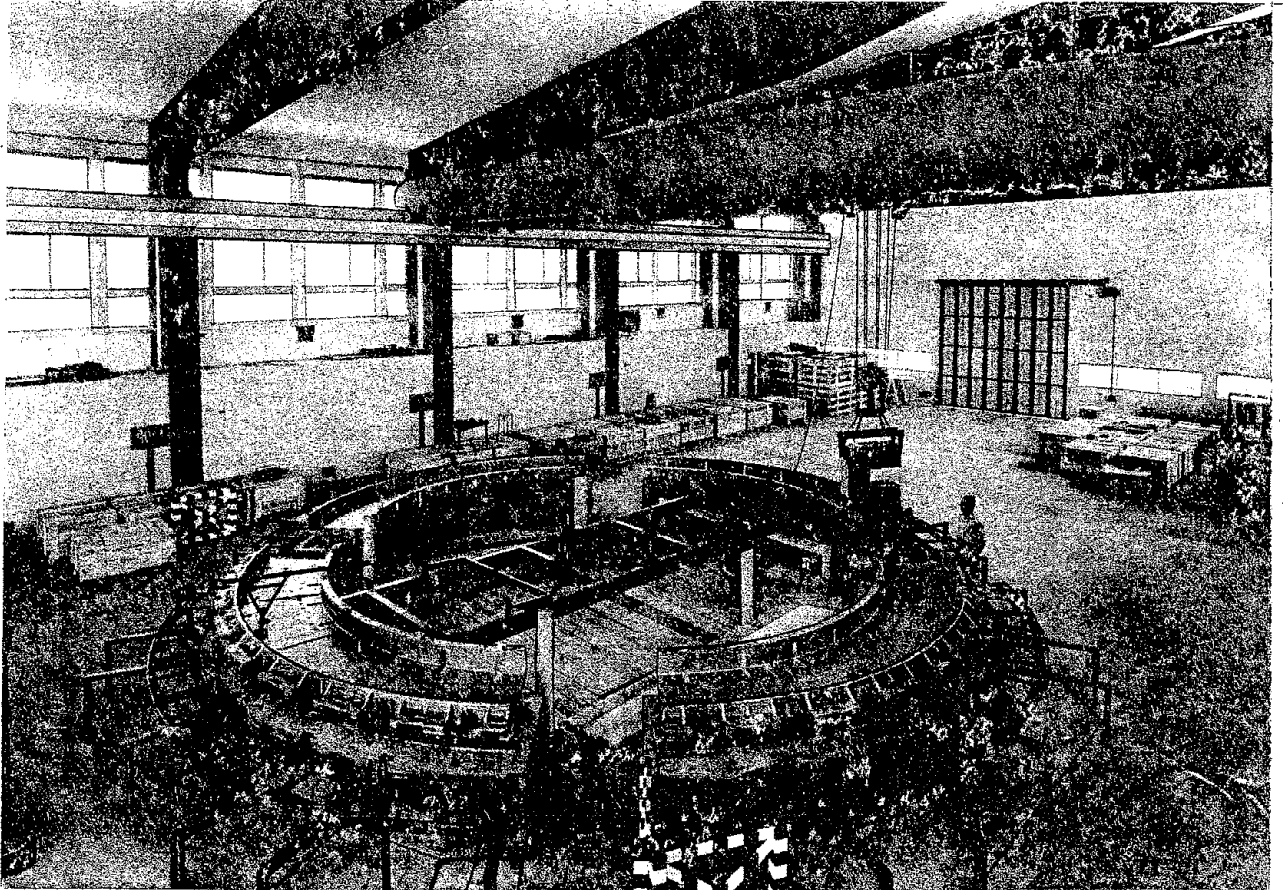

Fig. 6 - Magnet Steel Basis (September 1957)
On the right: One of the Silicon Steel Blocks

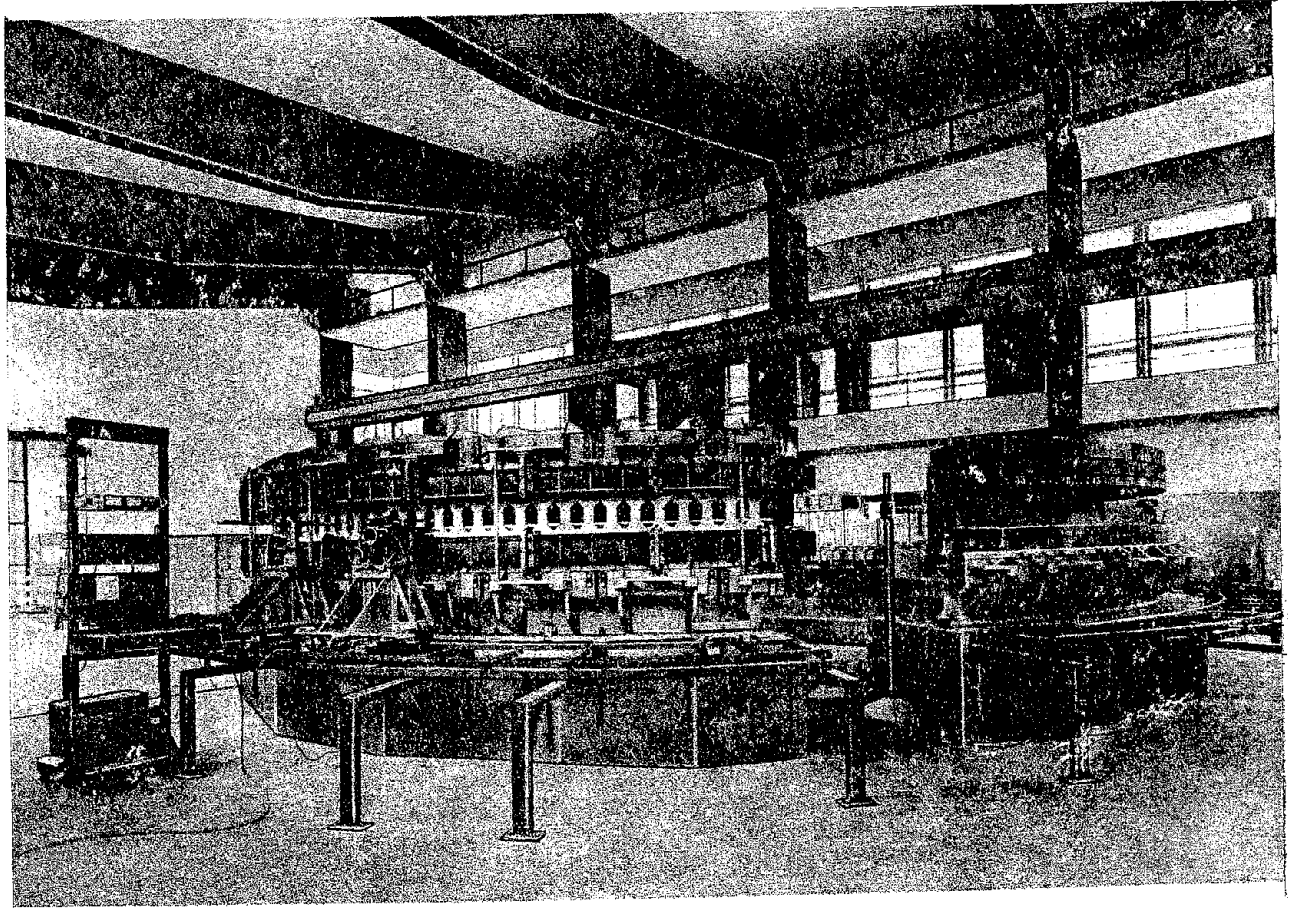

Fig. 7 - Magnet Assembling (November 1957)

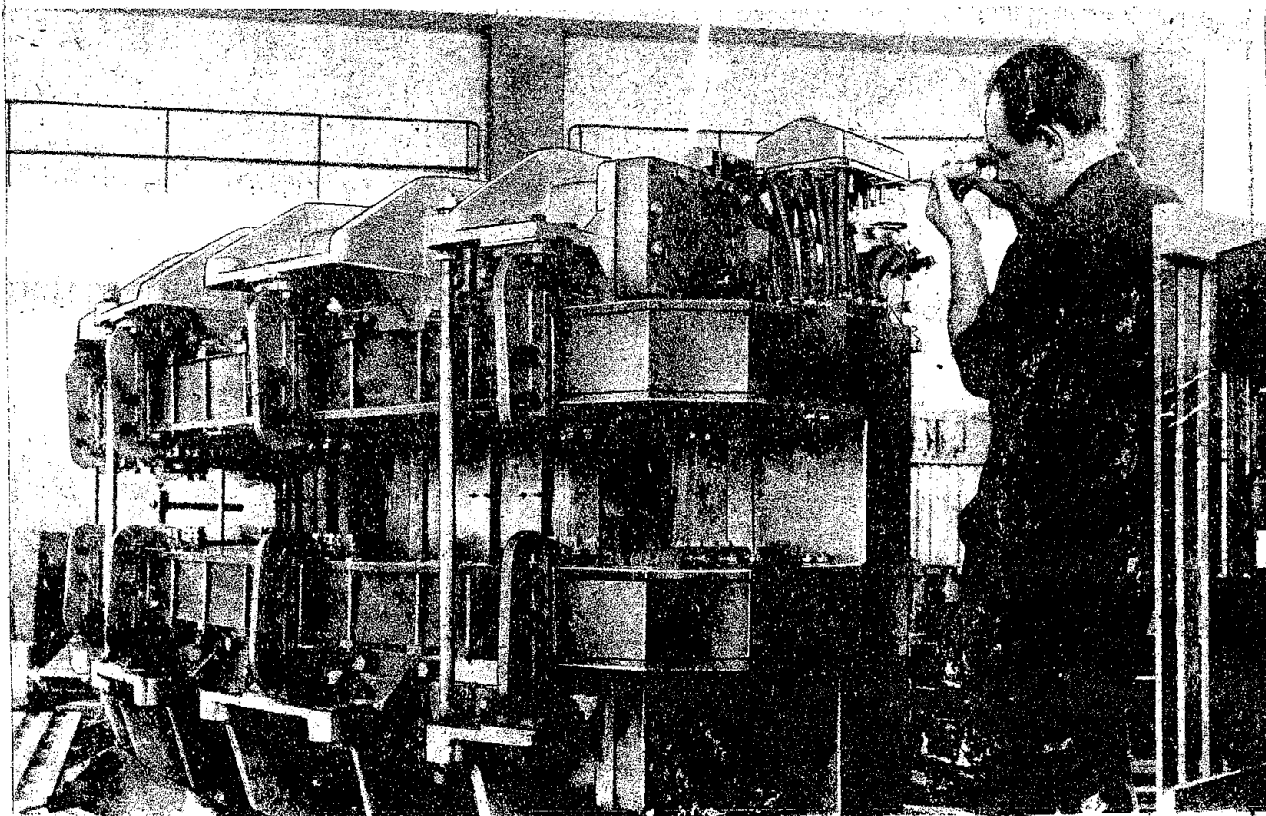

Fig. 8 - Magnet Assembling. Fixing of Cooling System
for Excitation Coils

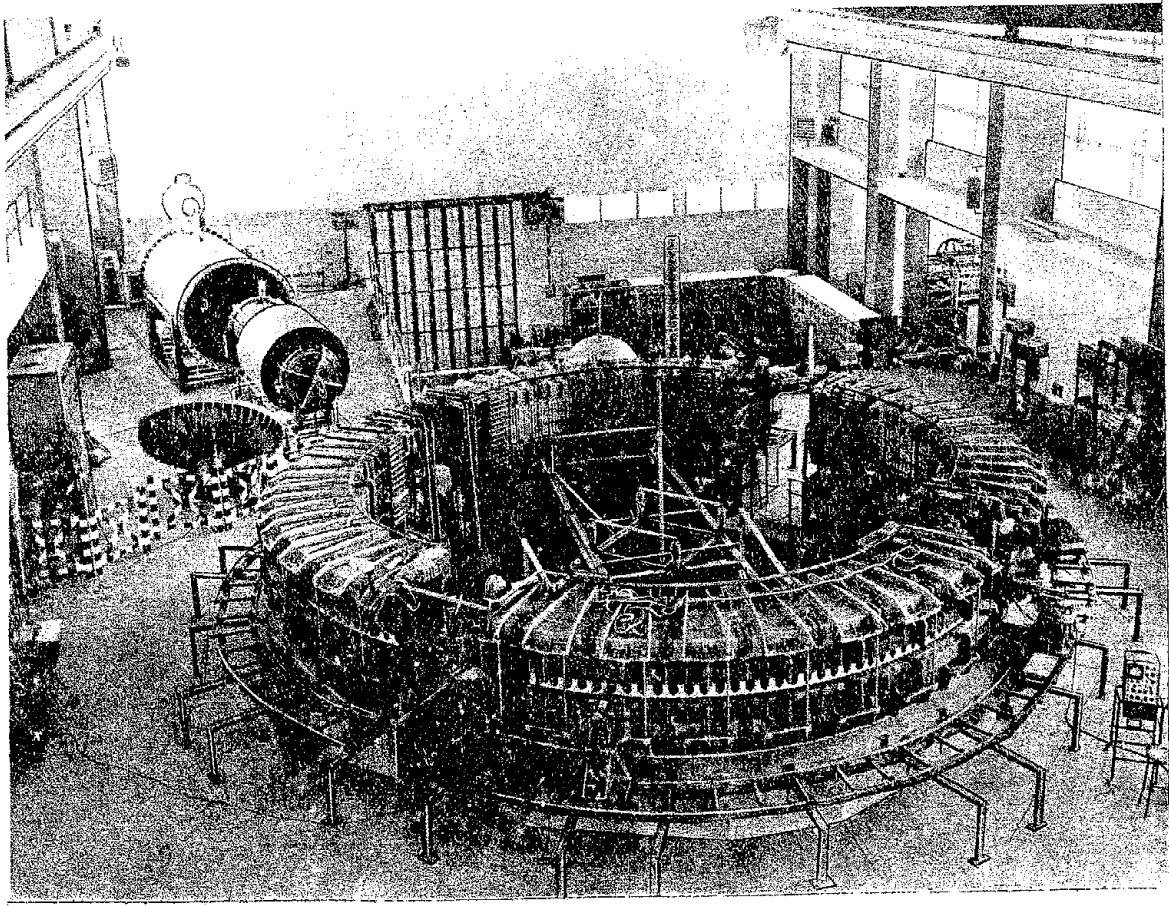

Fig. 9 - General view of the Magnet (April 1958)
In the background: left, the Injector;
right, the Power Control Room

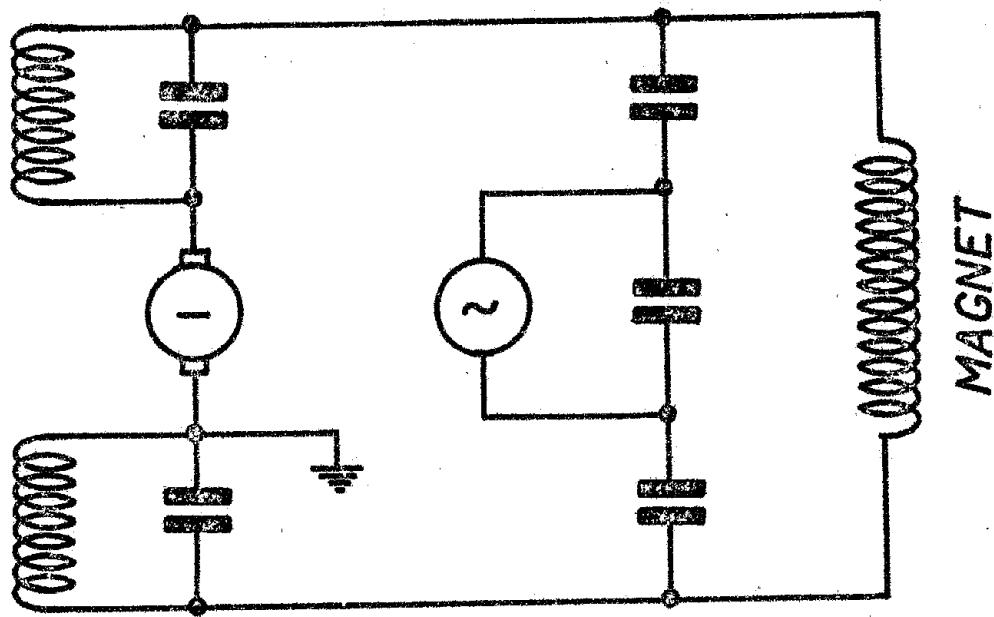

FIG. 10 - MAGNET POWER SUPPLY

- Capacity of the condenser
bank : = 3420 μ Farad

b) Our general program is not very different from the standard for a weak focusing machine. Of course, measurements are harder to perform with an Electronsynchrotron than with a Protonsynchrotron and we found it more convenient in some cases to reach a new level of sensitivity and precision. Here are a few results :

Fig. 11 gives the n -value as a function of a radial coordinate in the gap. This measurement was taken at 500 Gauss, d.c. As one can see, the useful region is of the order of 11 cm.

Fig. 12 gives the n -value at injection, 23 Gauss, when there is full excitation. The measurements were taken in and outside the median plane. (± 1.5 cm).

Fig. 13 gives the n -value as a function of θ , the azimuth, for each quadrant.

Fig. 14 shows the magnetic median plane position as a function of azimuth, for each quadrant, at 500 Gauss, d.c. The measurement, achieved with a precision of ± 0.2 mm, was made possible by means of a new instrument, prepared by Dr. G. Diambri of our Laboratories (3).

We are developing a quite complicate system of correcting coils. Fig. 15 shows an example of the kind of magnetic field gradient controls planned by us, with the correcting coils distributed along the gap. The experimental results referred in the above mentioned figure were obtained at about 250 Gauss.

(3) - Diambri, G. CERN Symposium, Vol. I, 471 (1956)

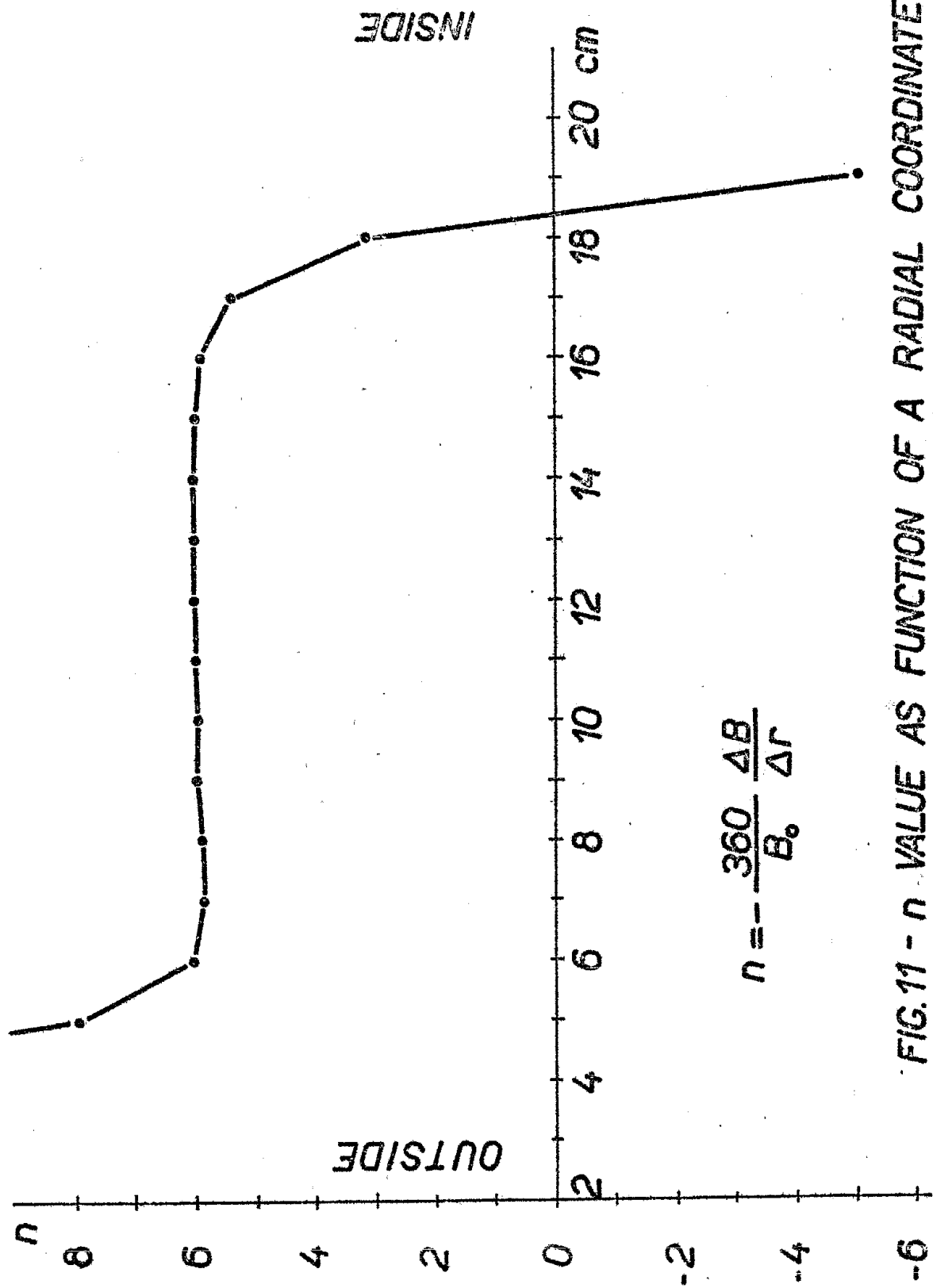

FIG.11 - n VALUE AS FUNCTION OF A RADIAL COORDINATE IN THE GAP AT 500 GAUSS

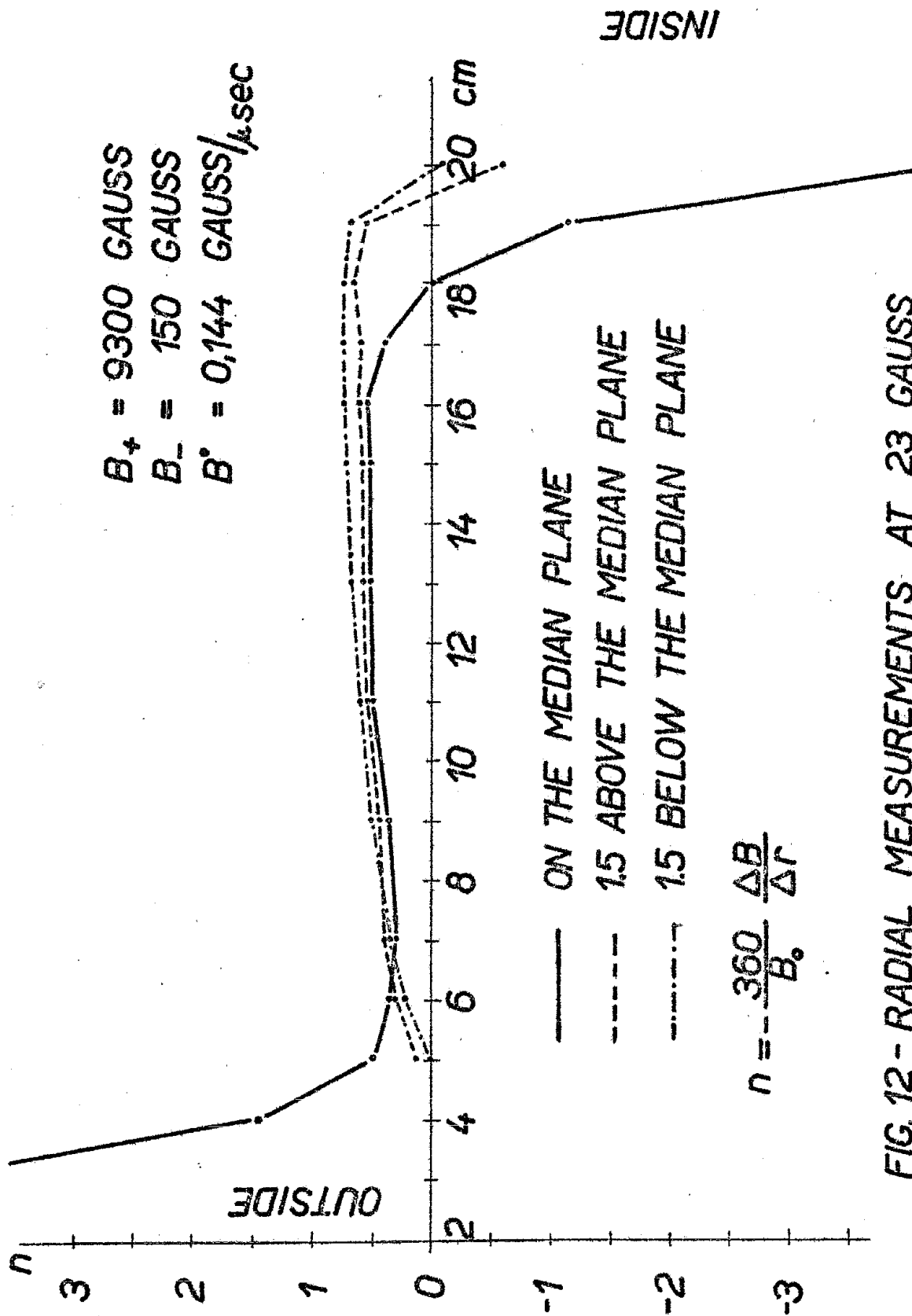
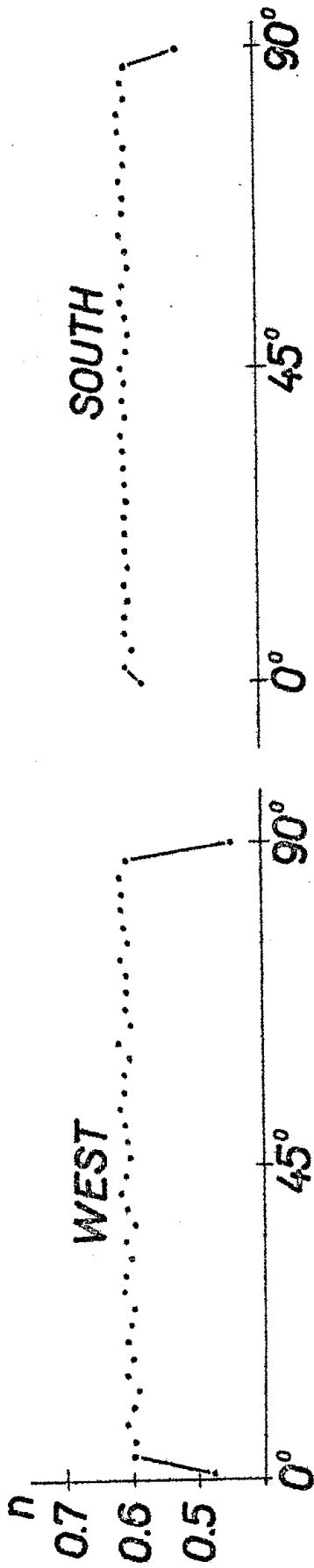
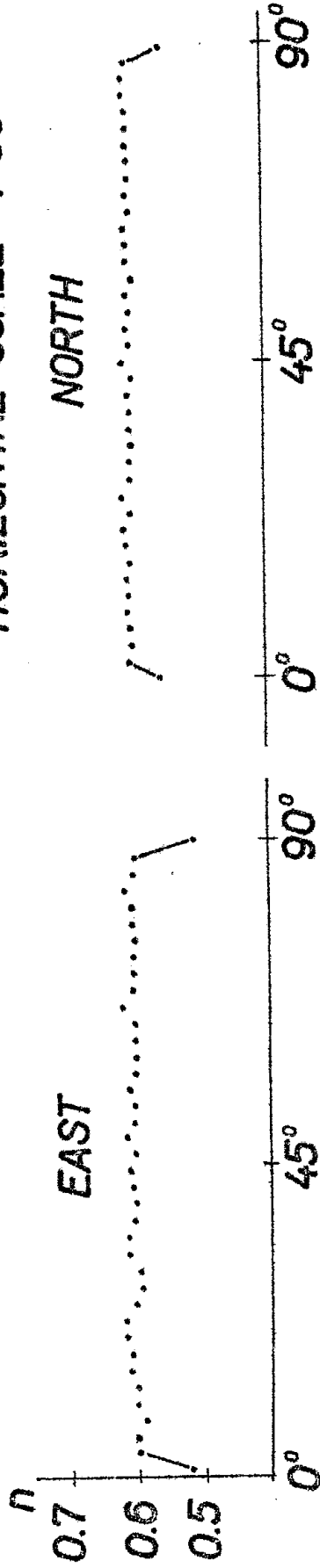

FIG. 12 - RADIAL MEASUREMENTS AT 23 GAUSS
FULL EXCITATION

QUADRANTS:



HORIZONTAL SCALE 1:60



$$n = -\frac{360}{B_0} \frac{\Delta B}{\Delta r}$$

MEAN n -VALUE ON THE 4 QUADRANTS: $n = 0.605$

FIG. 13 - AZIMUTHAL MEASUREMENTS OF n AT 500 GAUSS D.C. IN THE 4 QUADRANTS

QUADRANTS:

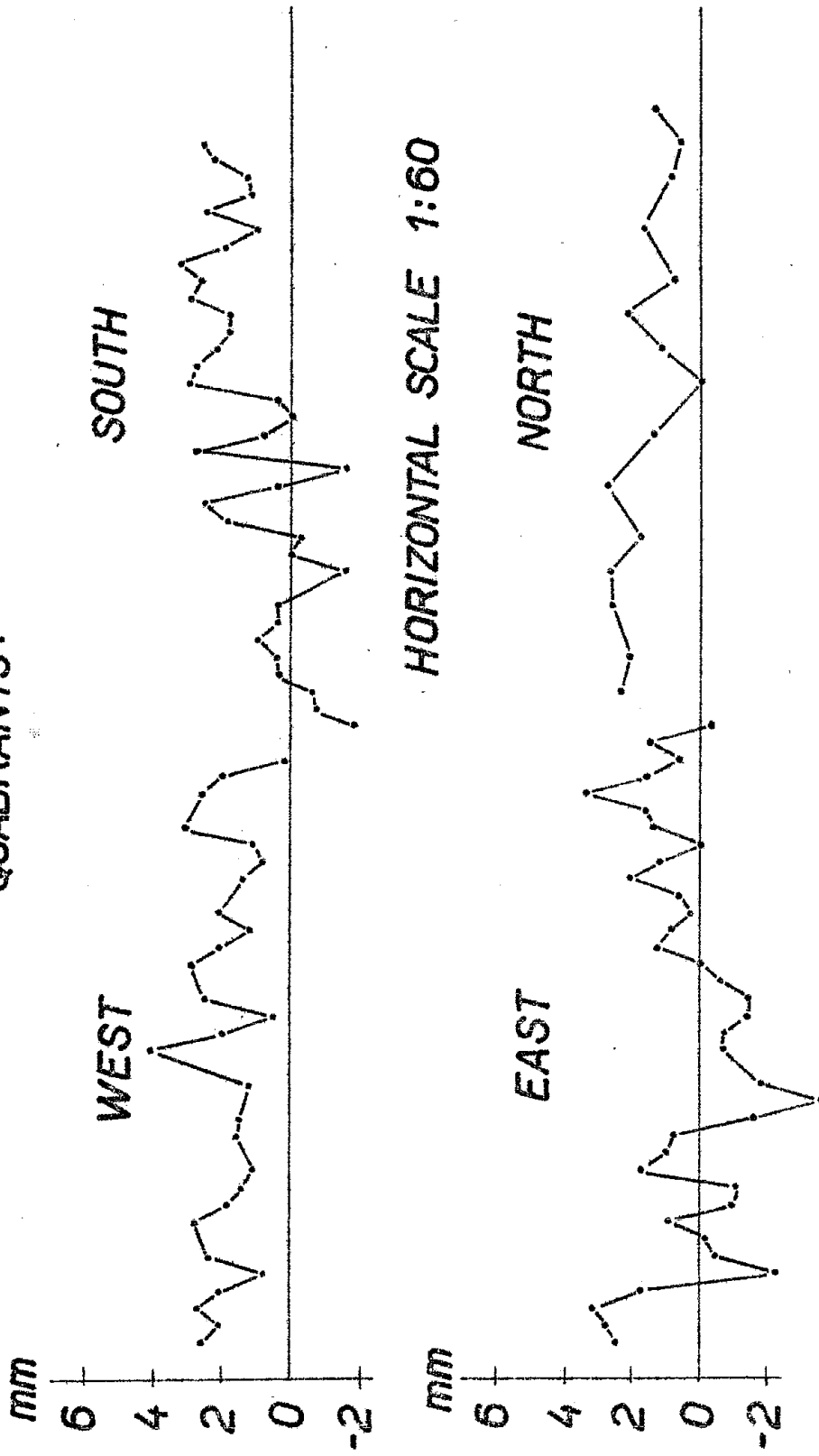

FIG.14 - MAGNETIC PLANE POSITION AS FUNCTION OF AZIMUTH
AT 500 GAUSS

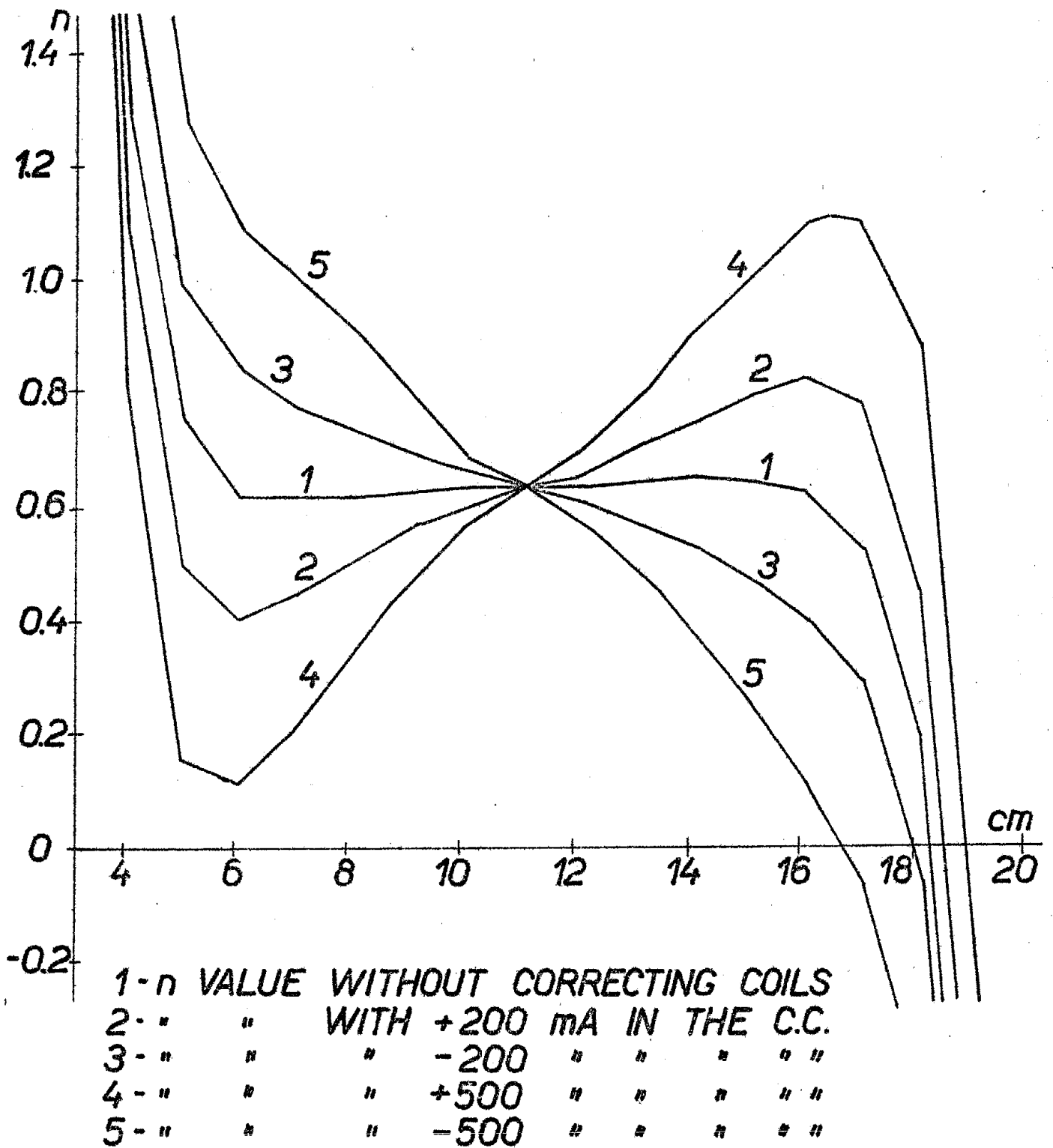

FIG. 15 - CORRECTING COILS EFFECT

Our studies of the correcting coils system include also the possibility of enlarging the useful area of the gap by pulsing rather large currents (enlarging coils) in the right place, near the end of the gap. The possible results with the enlarging coils have been already reported (4).

As a general remark, it shall be said that our technique of measurement rests heavily on the use of peaking strips; these have to be carefully treated in order to make them become reliable detectors.

§ 4. - The Injector.

The injector is of the Cockroft-Walton type, with solid rectifiers. Its main data are : (5)

- Type : Cockroft-Walton in pressurised tank
- Gas pressure in the tank: \approx 15 atm.
- Gas type : Azote with a CO₂ or Freon % (approx. 10%)
- Dimensions of the tank (approx.)
 - length : = 5 m
 - width : = 3,5 m
 - height : = 3,5 m
- Tank material : stainless steel
- Electrons energy : = 2,5 MeV (total)
- Max. current : approx. 200 mA
- Length of the pulse : from 1 to 10 μ s.

(4) - Salvini, G. and. Sanna, G. CERN Symposium, Vol. I, 458 (1956)

(5) - The 'Istituto Superiore di Sanità', where the project for this Injector was studied, cared also for the realization and setting of the same.

- Power supply frequency := 1000 cycles
- Electric structure := 5 stages of 400000 Volts,
Westalith rectifiers
- Ripple : of the order of 2×10^{-4}
- Inflector : electrostatic, 60 degrees
- Required stability of
injection energy : = 0,2 %
- Angular opening of the
beam at injection : = $\pm 3 \times 10^{-3}$ rad or less

For further details, see Fig. 16 and Fig. 17.

§ 5. - The Radiofrequency System.

The electrons will be accelerated by two resonant cavities, located in two of the four straight sections of the magnet. These cavities will oscillate in 4th harmonic: the first cavity will operate in the first stage of acceleration, from 2 to about 8 MeV of kinetic energy, with frequency modulation from 42.6 MHz up to 43.7 MHz. Fig. 18 shows a section of the first cavity; dimensions are indicated in mm.

The second cavity is modulated only in amplitude, at a fixed frequency of 43.7 megacycles and a max. voltage of 50-60000 V. The power of the system is of about 60 kW.

Both cavities will be driven by power amplifiers. While the first cavity is traversed by the doughnut itself, the second high power cavity cannot allow any dielectric at the gap and it will be therefore in part under vacuum. Besides, the second cavity requires water cooling, and an extra d.c. voltage, in order to avoid multi-pacting.

The amplifiers chain of the second cavity includes following stages : pilot oscillator, buffer sta-

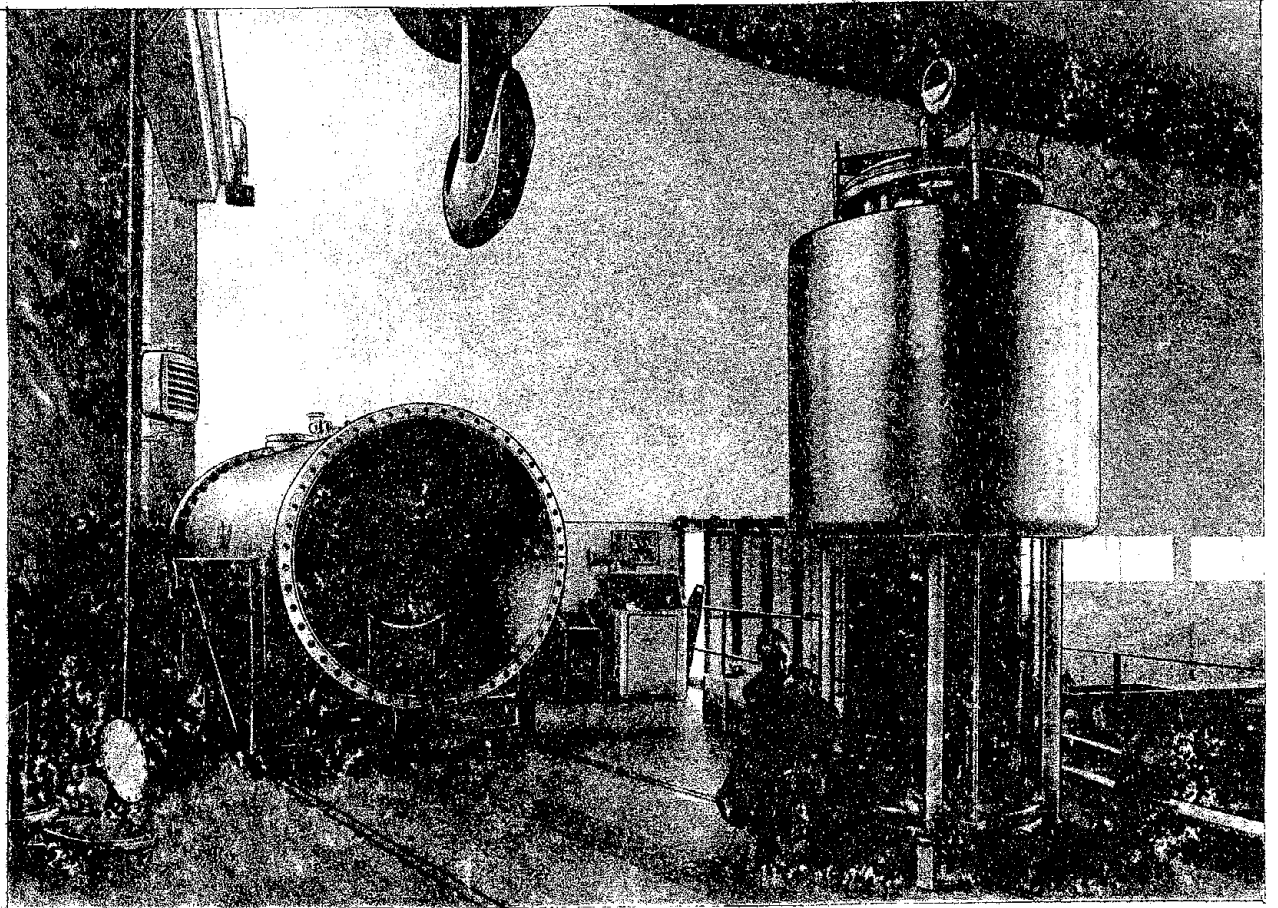

Fig. 16 - The Injector. Open Tank and H.V. Device

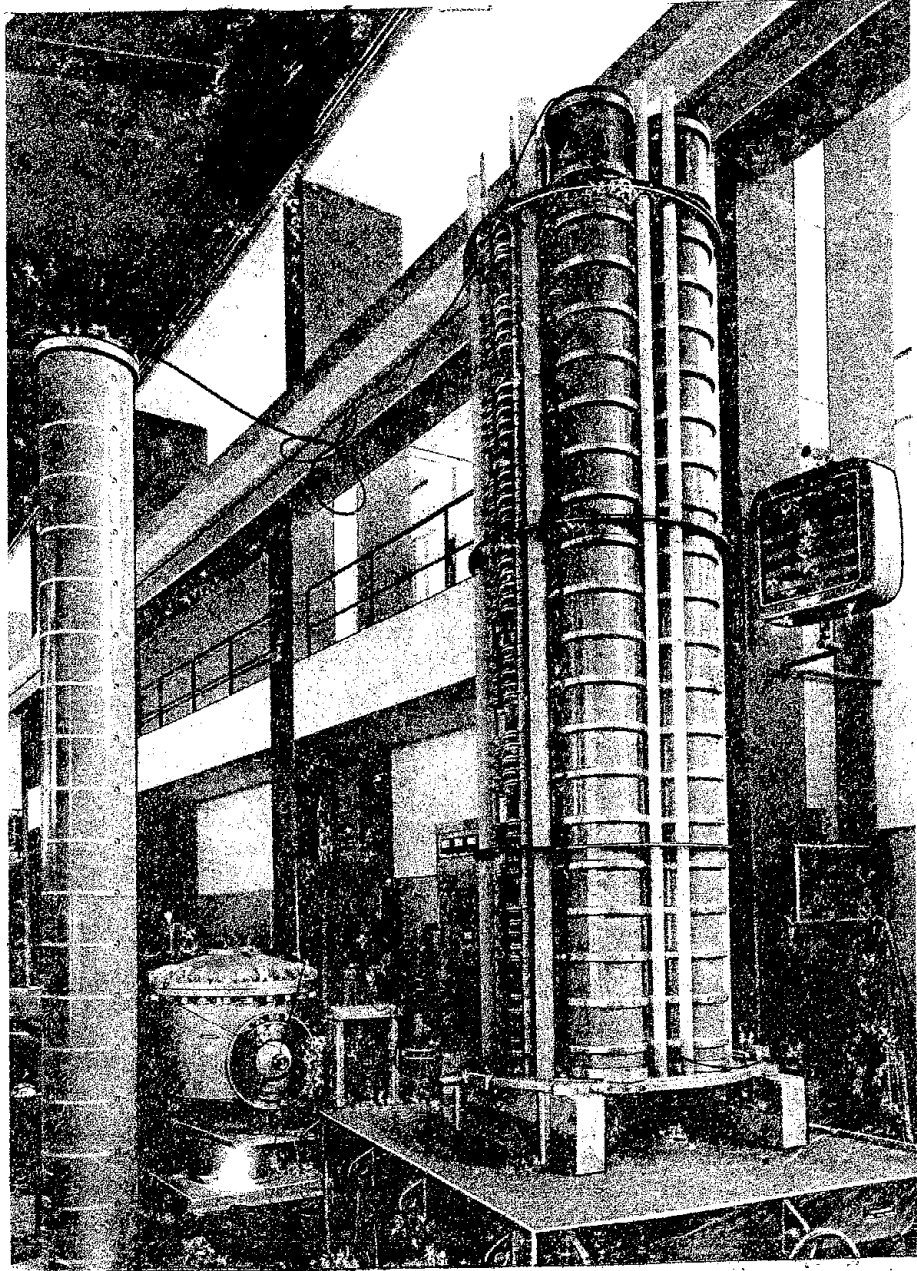
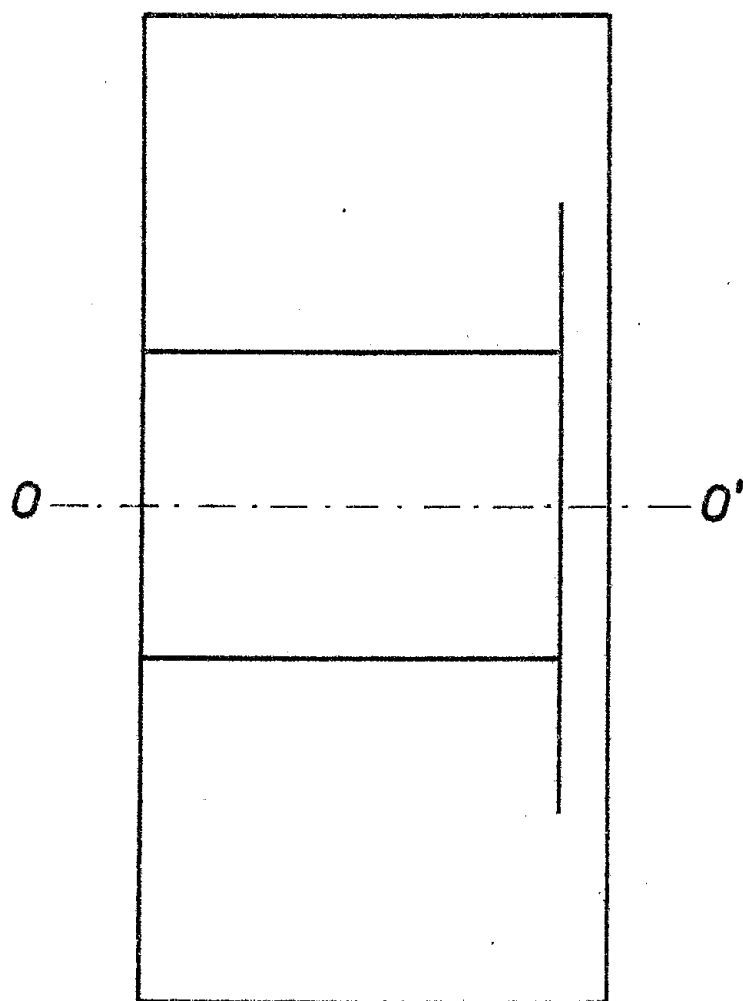

Fig. 17 - The Injector. Condensers and Rectifiers Columns



0 10 20 30 40 50 cm

FIG. 18 - SCHEME OF THE FIRST ACCELERATING SYSTEM (RF₁). THE CAVITY IS APPROX. A SOLID OF ROTATION ROUND THE AXIS OF 0-0'

ge, prefinal and final stage.

The first two stages are of the conventional type, with concentrated constants; their tubes are, respectively, of the QB3/300 and QB5/1750 type. Prefinal and final stages are assembled by using circuits with distributed constants, that is, coaxial lines on the plate and cathode circuit. The scheme is of the grounded grid type. The power rectifiers are all three-phase. Polarization of grids and filaments are stabilized.

The second cavity resonator has an electromagnetic structure, intermediate between coaxial and radial cavity. This form was chosen only because the axial over-all dimensions of the resonator are obliged.

The measured Q-value is of about 5000 and the characteristic impedance around 50 Ohm.

Fig. 19 shows the RF₁ cavity, the power supply and the controls. The second, 60000 Volts cavity, is visible in Fig. 20.

We calculated the maximum voltage V_{max} required in the RF₂ cavity due to the radiation losses of the electrons. (6) In fact, the cross section of the beam circulating in an Electronsynchrotron increases with the energy, mainly because of fluctuations in the radiation losses (6). On the other hand, the maximum amplitude of the Synchrotron oscillations accepted at a given RF system is an increasing function of its peak voltage. In order to maintain the electrons beam at the highest energies, the allowed Synchrotron oscillations, of amplitude X_M , must be larger than $\langle \beta_s^2 \rangle^{1/2}$, the root

(6) - Bernardini, C. Report T 29 of the Frascati Laboratories

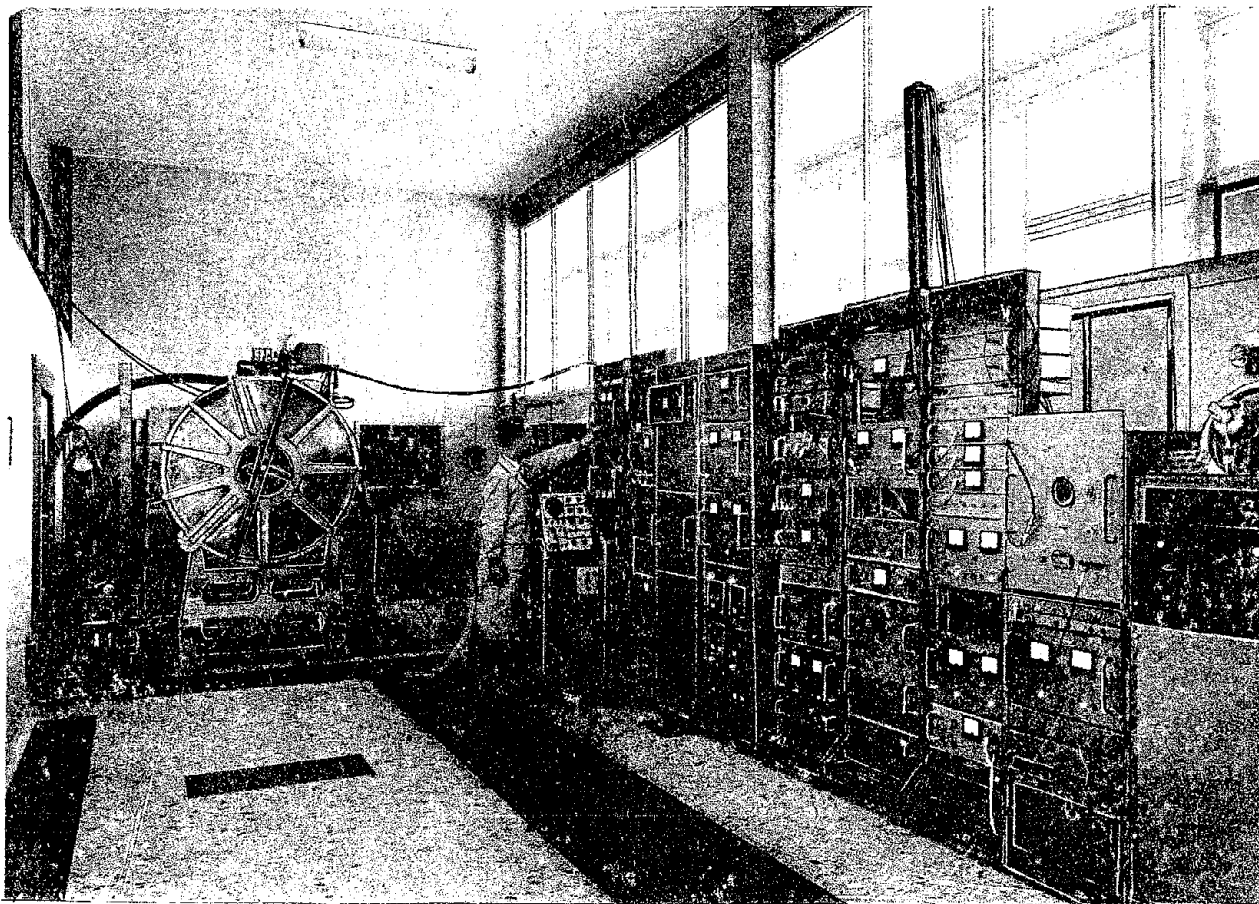

Fig. 19 - RF₁ Cavity with Power Supply and Controls

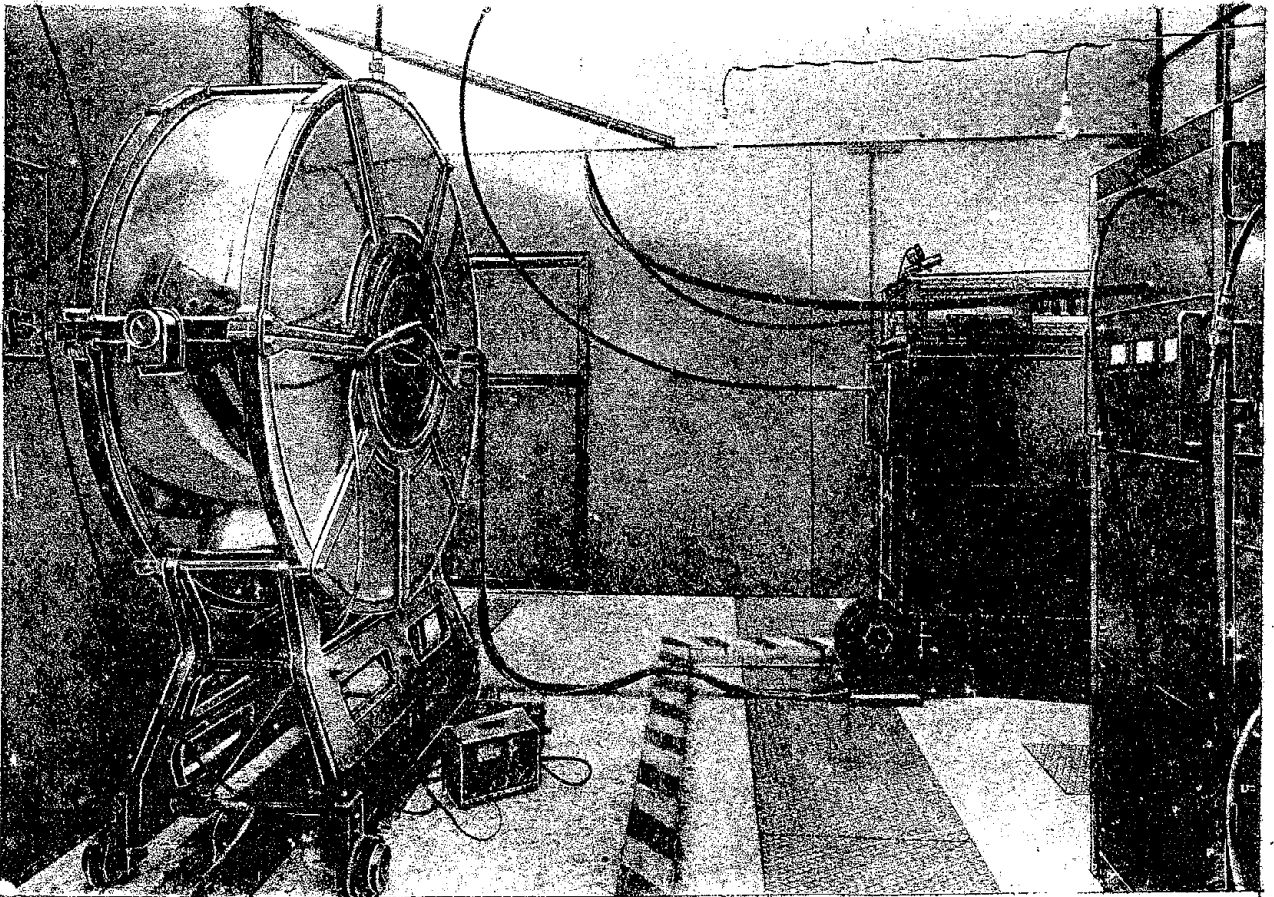

Fig. 20 - RF₂ Cavity

mean square amplitude (radius) of the beam. This condition is shown in Fig. 21 : it appears clearly that the RF₂ cavity should have, in the present machine, a max. voltage of at least 50000 Volts.

Of course, the timing of the successive operations during the acceleration cycle (main Synchronizer = M.S.) - that is the time coordination between injector, magnet, RF₁, RF₂, a.c. - is of main importance (7).

The M.S. is supposed to perform at each cycle the following operations at correct times :

- Inject a beam of electrons from the injector
- Turn on the RF₁ power
- Programming the RF₁ frequency modulation
- Turn off the RF₁ power, turn on the RF₂ power
- Programming the amplitude modulation of the RF₂ peak voltage.

It is convenient that the operation of M.S. tracks the instantaneous value of the electrons energy: this is the reason why the value B of magnetic field of the magnet was chosen as independent variable for the working of the M.S., instead of the time in itself. This allows changes of dB/dt around the injection, without causing any compulsory changes in the M.S. program.

The information from field B to the M.S. comes through pulses from biased peaking strips; the required time precision for the pulses is of the order of 10^{-7} sec.-

(7) - Alberigi, A., Lepri, F., Puglisi, M. and Quercia, I. F.:
Report R 12 of the Frascati Laboratories.

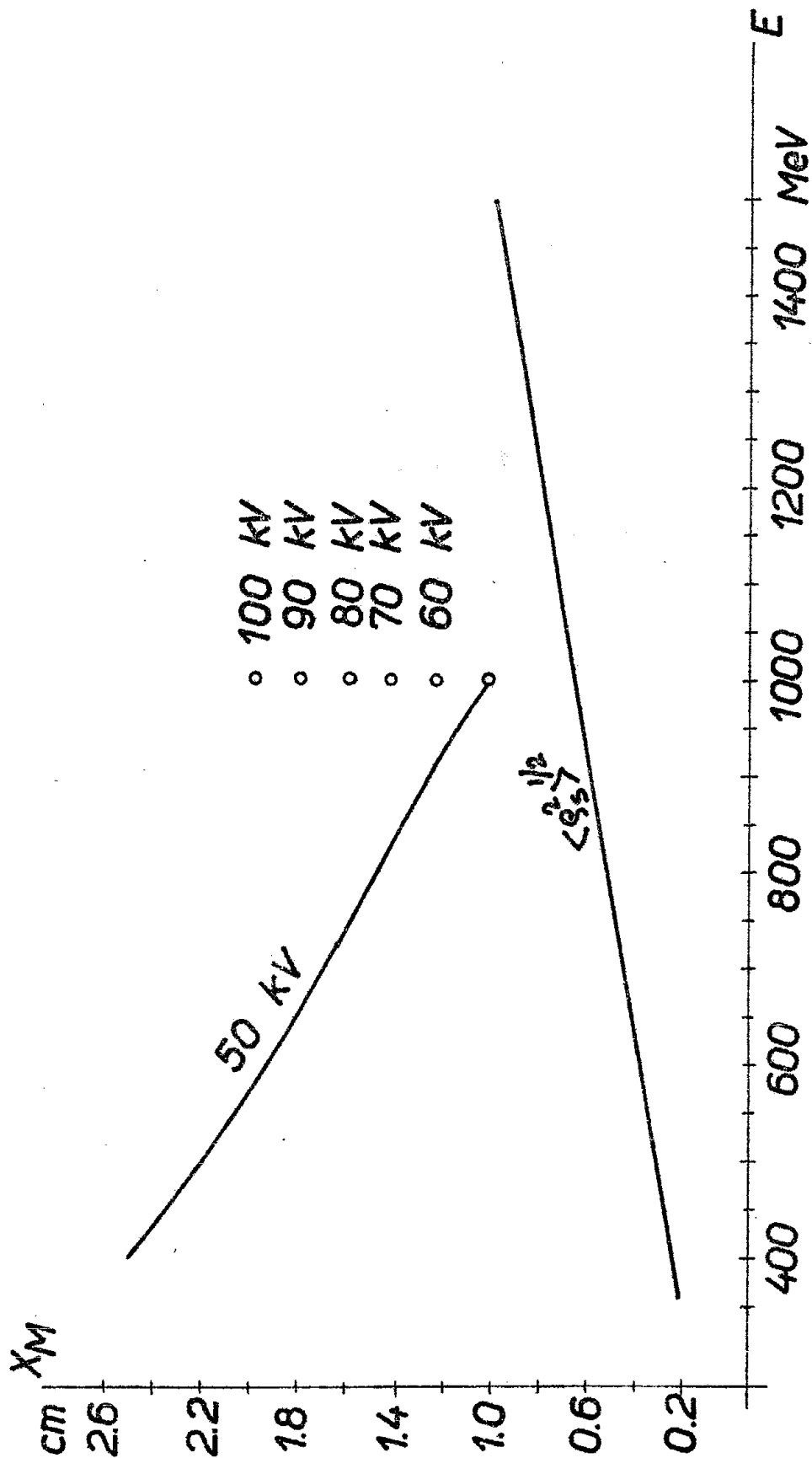

FIG. 21 - LIMIT AMPLITUDE OF SYNCHROTRON OSCILLATIONS X_M VERSUS ENERGY FOR VARIOUS PEAK RF VOLTAGE; R.M.S. RADIATION INDUCED AMPLITUDE $\langle S_s^2 \rangle^{1/2}$.

§ 6. - Vacuum System and Doughnut.

Our doughnut is built of araldite and quartz powder, this latter acting as an hardener (8).

The Doughnut is of a rather complex structure, one of its characteristic features being the 5/100 mm thin stainless steel strips laid innerly to prevent accumulation of charge on the inside surface.

Herebelow are the main data of Doughnut and Vacuum System :

- Capacity of each rotating pump	:	= 60 mc/h
- Final pressure	:	= $10^{-5} + 10^{-6}$ mm Hg
- Doughnut material	:	araldite and quartz
- Doughnut dimension (external)	:	= 230 x 78 mm
- Doughnut wall thickness	:	= 11 mm
- Number of diffusion pumps	:	= 4
- Pumping speed of each diffusion pump	:	= 3000 l/sec.
- Number of rotating pumps	:	= 4

For details concerning construction of our doughnut, see Fig. 22.

Two doughnut pieces, ready to be collocated into the magnet, are shown in Fig. 23.

§ 7. - The present stage of the machine.

The Synchrotron parts herein described are

(8) - Corazza, G. : Report DO 15 of the Frascati Laboratories.-

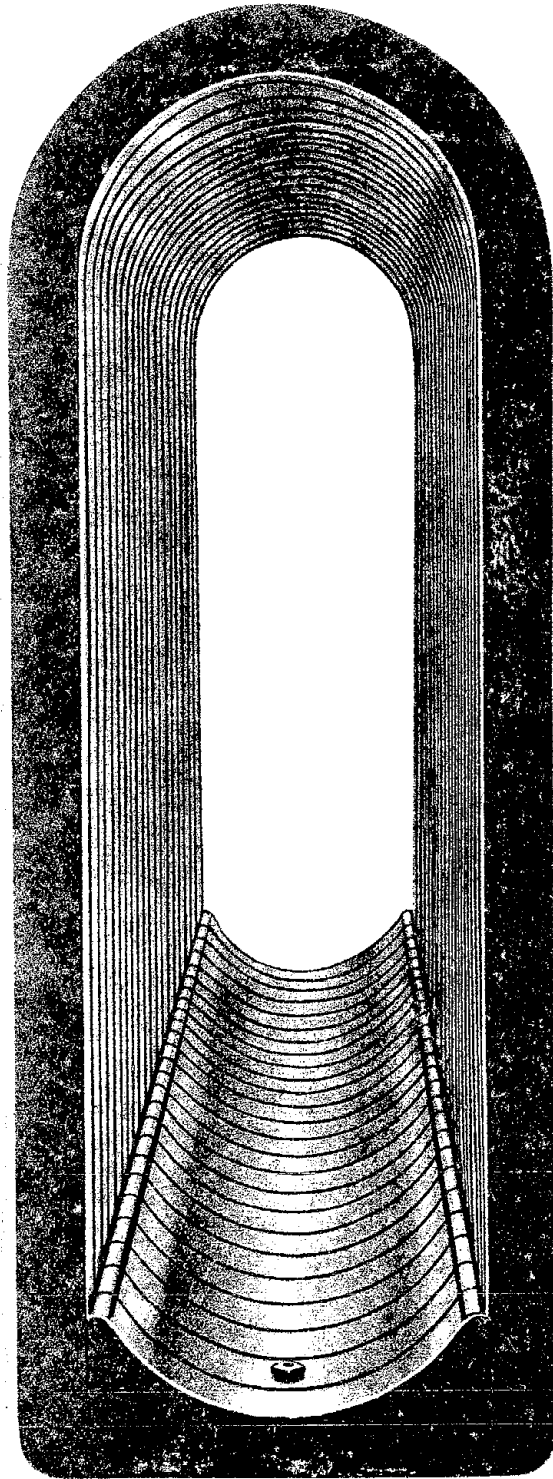

Fig. 22 - Inside view of a Doughnut Section

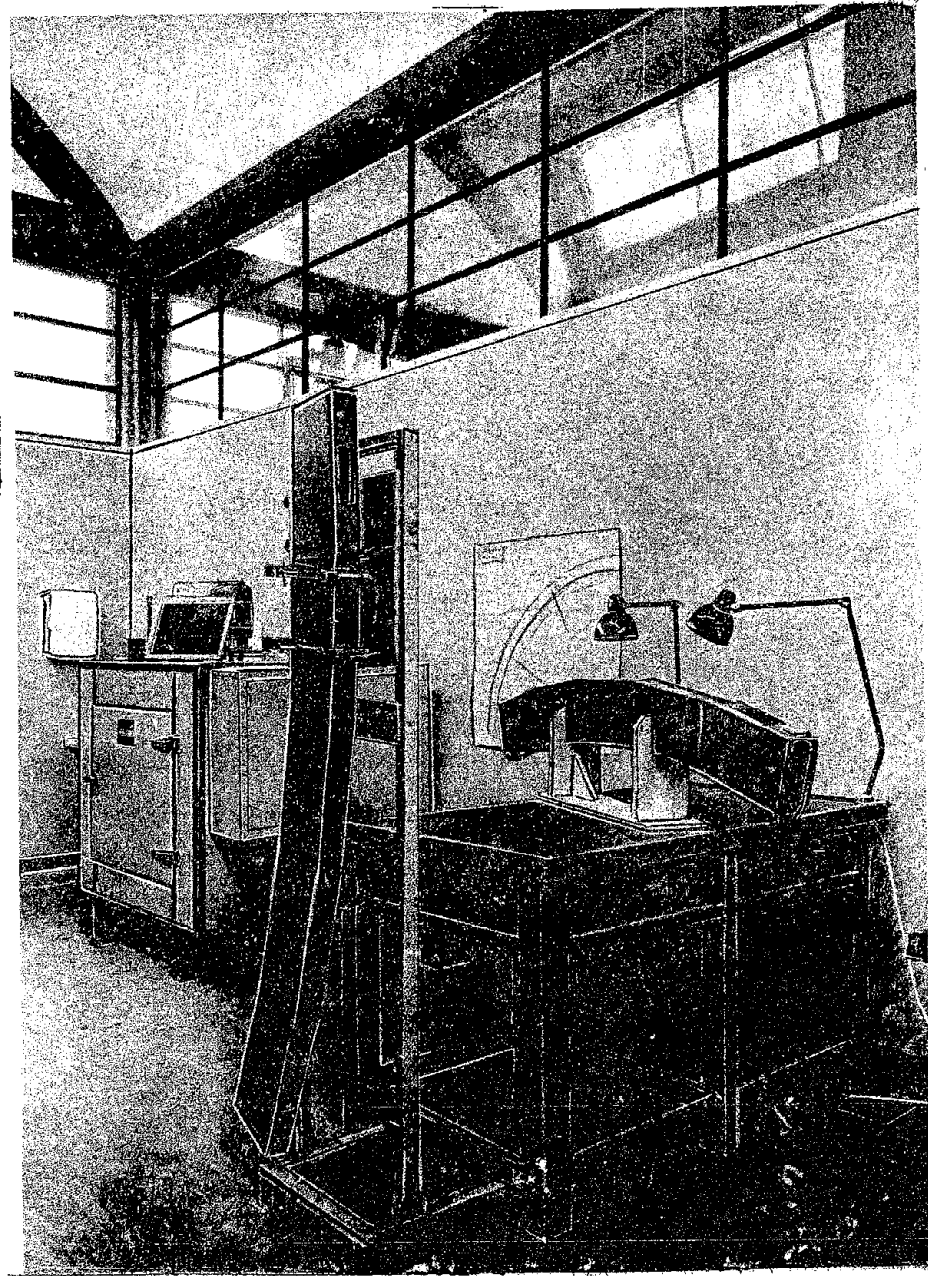

Fig. 23 - Two Doughnut Pieces

all ready. The vacuum system was also assembled, and re-search of the beam will start within a few weeks.

§ 8. - The Research Program.

Our scientific research program should not be too different from what is presently in progress with similar machines in the U.S.A. We want here to stress a few particularities of our machine for a more definite characterization of the same.

The injector, and the type of focusing that was chosen, are supposed to allow a high intensity of the circulating beam. In fact, the weak focusing should allow multi-turn injection, and the capacity of the Cockroft-Walton accelerator is higher than that of the commercial Van de Graaff accelerator. Recent experimental results on photoproduction are a clear demonstration of the necessity of a high intensity beam.

Among the general possibilities of our Laboratories, we shall mention the production of liquid H_2 and He. Our plant is supposed to supply 8 liters/hour. Fig. 24 shows a partial view of this plant.

Development of cryogenic research by using the Liquefier was considered as equally convenient. Results, obtained by the group of Prof. Careri, concerning diffusion of He^3 in He^4 are ready to be published.

Building analysing magnets takes a long time. A group of such magnets is now under construction. It concerns :

- a pair Spectrometer for a max. field of about 20000 Gauss, necessary to measure the intensity and momentum distribution of the X ray beam;

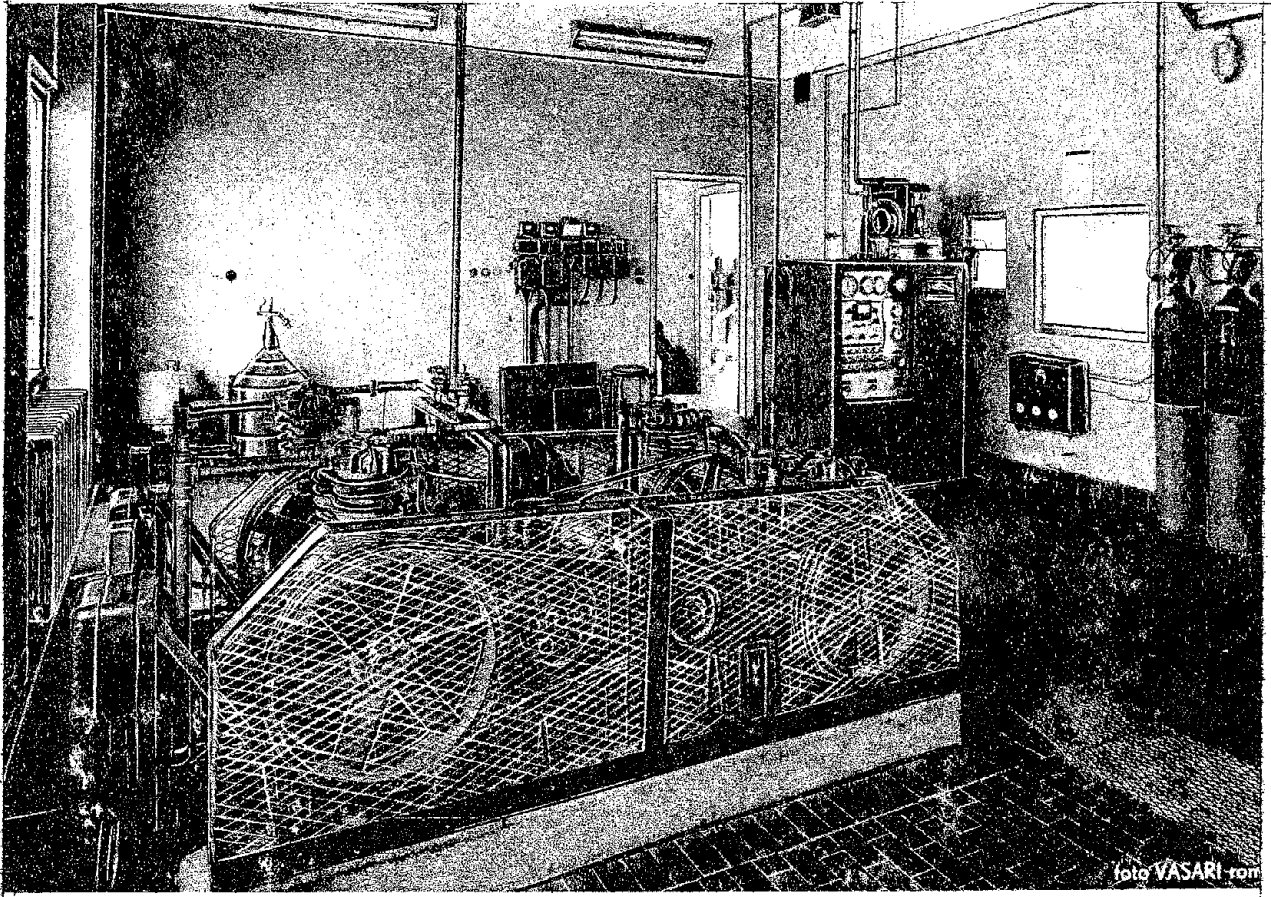
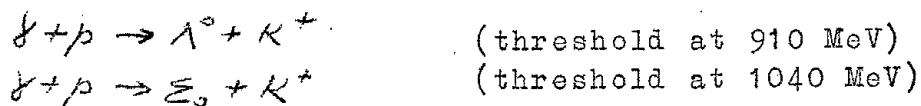

Fig. 24 - Cryogenic Laboratory. Partial View

- two analysing magnets with interchangeable poles (either parallel gap or strong focusing). Max. field 16000Gauss, weight about 20 tons;
- standard quadrupole lenses.

Among the possible directions to be taken by our future researches, we shall mention the following :

- Photoproduction of π mesons. Recent results have shown the great interest represented by the research on single and double photoproduction of pions at intermediate and high energies (from 500-1000 MeV), where new resonances may occur. (9). A group from the Rome University is preparing a counters plus magnet experiment (10) on single photoproduction, including the use of Cerenkov gas counters. A bubble chamber is now under construction for possible use in the research of double production of pions, and in general on multiple processes;
- Research on the structure of the nucleon, based on studies of the electromagnetic cross sections in close photon-nucleon and electron-nucleus collisions;
- Photoproduction of K particles (10). Our machine will develop enough energy for measurements of the



reactions, in a region around the threshold of the two processes quoted above.-

(9) Wilson, R. Preprints and private communications from the Laboratories of Nuclear Studies of the Cornell University.

(10) Experiments in project with the Electronsynchrotron. Report of the Frascati Laboratories.