

Laboratori Nazionali di Frascati

LNF-58/9 (26. 6. 58)

I. F. Quercia: ELECTRONIC APPARATUS FOR THE MEASUREMENT  
OF DYNAMIC MAGNETIC FIELDS.

Relazione n°: M 72  
26 Giugno 1958.

I.F.Quercia: ELECTRONIC APPARATUS FOR THE MEASUREMENTS OF  
DYNAMIC MAGNETIC FIELDS.-

Summary:

An apparatus is described which reproduces by a staircase voltage waveform a magnetic field rising between 0 and about 120 gauss. The device is well suited for the measurement of the instantaneous value of the magnetic field in the gap of an Electronsynchrotron. It consists of a peaking strip magnetic probe, and an electronic apparatus.

Introduction:

The problem of measuring the instantaneous value of a magnetic field which is changing in time arises rather frequently in research and in technological work. Many devices have been developed by different authors, which are well suited for the particular situations for which they have devised.<sup>(1)</sup> The apparatus described in the present paper has been developed with the purpose of measuring the rising magnetic field in the gap of the 1 GeV Frascati Electronsynchrotron between 0 and about 120 gauss. The apparatus produces a voltage waveform which accurately reproduces the magnetic field increasing with rates of rise between .05 gauss/ $\mu$ s and

---

(1) The paper: J.L.Symonds: Methods of measuring strong magnetic fields. Rep.Progr.in Phys. 18, 83 (1955) presents a very useful summary of the different technical approaches to the problem, developed up to that date.-

.3 gauss/ $\mu$ s, and is well suited, for instance, for controlling the frequency modulation program of the Radio Frequency accelerating system of the Synchrotron. We think that, with some modifications, it would be possible with a similar apparatus to track magnetic fields rising to higher values; in that case the apparatus would be useful for many other applications, e. g. the programming of frequency modulation in Proton Synchrotrons.

The apparatus consists of a 'magnetic probe' and an 'electronic device', which will be described in the following paragraphs.

Magnetic probe: The magnetic-sensitive probe is a biased 'peaking strip'; its pulses are used to drive an electronic apparatus. As is well known,<sup>(2),(3)</sup> a 'peaking strip' is a length of wire of a magnetic material with high permeability; in our case it is a wire of 'Ultraperm 10', 20 mm in length, .025 mm in diameter. The static hysteresis loop of such a wire is very narrow so that only a few hundredths of an oersted are required to reverse the direction of the magnetic polarization inside the wire.<sup>(4)</sup> In a coil wound around this wire a voltage pulse is induced every time the magnetic polarization of the wire is quickly reversed. The high permeability magnetic wire and the pickup coil together are usually called a 'peaking strip' (referred to as PS in the following).

In our case the PS is surrounded by a coil in which a biasing current can be injected. The voltage pulse

---

(2) J.M.Kelly, Rev.Sci.Instr. 22, 256 (1951)

(3) S.Giordano, G.K.Green, E.J.Rogers, Rev.Sci.Instr. 24, 848 (1953)

(4) Wires of 'ultraperm 10' were furnished by: Vacuumschmelze Aktiengesellschaft Hanau, Gruener Weg 37 - West Germany. The wire was contained in a quartz tube as shown in fig.1 and was cemented with araldit to the tube according to the procedure described by: G.Diambrini, N.Cim. 3,336(1956)

is produced by the PS when the sum of the field to be measured and the field due to the biasing coil, crosses the zero value, reversing the magnetic polarization of the wire. In this way a voltage pulse is produced by the device, every time the field to be measured by the probe, reaches the value of the biasing field. In Fig.1 the dimensions of the probe are given together with the characteristics of the pickup and biasing coils.<sup>(5)</sup>

Electronic apparatus : The electronic apparatus injects a current step <sup>in</sup> the biasing coil, every time it is triggered by a positive pulse from the PS. If we suppose that the rest bias current corresponds to a magnetic field  $-H_0$ , the first pulse is produced <sup>by</sup> the PS when the measured field reaches the value  $B_0 = +H_0$ . This first pulse triggers the electronic device, and a step of current is injected in the bias coil; the biasing field is thus raised to the value  $H_1 = -(H_0 + \Delta H)$ . While the bias field rises from  $-H_0$  to  $-H_1$ , the measured field increases by an amount  $\Delta B$ . If  $\Delta B$  is less than  $\Delta H$ , the total field at PS is reversed and a negative pulse is generated. Now the PS is ready to give out a second positive pulse when the measured field reaches the value  $B_1 = -H_1$ . This second pulse causes a second step of current to be injected in the bias coil, and the process is repeated (see Fig. 2). In this way the biasing field is increased by steps, of amplitude  $\Delta H$ , each step being triggered by the PS which in turn fires every time

---

(5) Note that a compensating coil ((5) in fig.1) is connected in series and in opposition to the pickup coil; this serves to reduce the voltages induced in the pickup coil due to the coupling between pickup and biasing coils.

the measured field is increased by an amount  $\Delta B = \Delta H$ . The 'staircase' formed by the successive steps reproduces the shape of the function of time  $B(t)$ , with an absolute error of the order of  $\Delta H$ .

The block diagram of the apparatus is shown in Fig. 3. The PS pulses have an approximate gaussian shape, with about 3  $\mu s$  rise time in a field rising at a rate of more than .1 gauss per  $\mu s$ ; the amplitude of the pulses is about 35 mV. These pulses are amplified by a conventional fast amplifier, having a gain of 200, and a rise time of about .5  $\mu s$ .

The pulses coming out from the amplifier are injected in<sup>a</sup> Schmitt amplitude discriminator; this selects the positive pulses from the negative ones and from the background.

The pulses from the Schmitt circuit are used to trigger a multivibrator, which produces standard negative pulses. The amplitude of these pulses can be varied between 0 and 8 Volt, by means of the 10  $K\Omega$  potentiometer in the plate circuit of the second tube; the duration of these pulses can be adjusted between 2 and 8  $\mu s$ , by means of the 10  $k\Omega$  potentiometer in the grid-cathode circuit.

The negative rectangular pulses from the multivibrator are injected in to an electronic integrator having a time constant  $\tau = RC$ . The integration of each pulse produces a step of voltage, of amplitude :

$$V_u = \frac{V_i}{\tau} T \quad \text{at the output;}$$

here  $V_i$  is the amplitude of the integrated pulse, while  $T$  is the duration of the pulse.

The leading edge of the step is a linear ramp having a slope :

$$V_i / \tau$$

Because of the finite gain  $G$  of the amplifier in the integrating circuit, the steps of voltage at the output decay exponentially with a time constant  $\Theta = G\tau$ . The scheme of the apparatus is given in fig.4. The integrating time constant is  $\tau = 100 \mu\text{s}$ , so that by changing the time duration of the pulses from the multivibrator, the voltage steps can be adjusted between .14 and .56 Volt. The gain of the integrating amplifier is about  $G = 50$  so that the decay time constant is about  $\Theta = 5000 \mu\text{s}$ .

In Fig. 4 the details of the Schmitt discriminator, the multivibrator and the integrating circuit are given.

The voltage steps from the integrating circuit are injected in a negative feed-back current amplifier, shown in Fig. 5. The current in the biasing coil is controlled by the EL34 power tube.

The current gain of this amplifier may be calculated as follows: the negative feed-back tends to cancel any voltage difference between the two grids of the input differential amplifier (tube E88CC).

If  $V_i$  is the voltage at the input grid, a current is developed by the power tube so that the voltage fed back to the second input of the differential amplifier is just equal to  $V_i$ . The voltage fed back is given by  $iR \frac{R_2}{R_1+R_2}$ , so that the current gain is :

$$\frac{i}{V_i} = \frac{R_1+R_2}{R_2} \frac{1}{R}$$

The output impedance of the current amplifier is a rather important parameter in our circuit for two reasons. First: the bias coil has an inductance of about  $L = 5 \text{ mH}$ , and a time constant  $t = L/r$  where  $r$  is the

output resistance of the current generator feeding the current in the coil; in our case it is necessary to have a time constant  $t < 1 \mu s$ , so that an output resistance  $r > 5,000 \Omega$  is needed. Second : the changing magnetic flux through the bias coil induces variable voltages at the terminals of the coils; the current in the coil must be independent from such voltages; this requirement is achieved by letting the current source have a very large output resistance.

A current feed-back amplifier has an output impedance given by (6) :

$$Z_{fb} = Z (1 - \mathcal{L})$$

where  $\mathcal{L}$  is the loop gain of the amplifier with the output (coil) terminals short circuited, and :

$Z$  is the output impedance of the power tube.

In our case the loop gain is not less than 1,000, assuming an output resistance of the triode connected EL34 of  $Z = 10,000$  ohm, the output impedance of the current amplifier is of the order of 10 Megohms, large enough for our purposes.

#### Performance of the apparatus.

Tests have been made by putting the probe at various distances in the fringing field of a magnet, excited by 50 c/s A.C. current. The peak value of the field in the gap of the magnet was above 1,500 gauss, so that, in the fringing field, rates of rise of the field the order of .4 gs/s were easily reached.

With a rate of rise of the field at the probe site of .1 gauss/ $\mu s$  a field of 90 gauss is reproduced by

---

(6). See e.g.; T.S.Gray : Applied Electronics - II Ed.1954  
Pag. 587 - John Wiley e Sons, Inc.

29 steps, with an average value of  $\Delta H = 3$  gauss/step (see Fig. 6).

With a rate of rise of  $.3$  gauss/ $\mu$ s, a field of 90 gauss is reproduced by 14 steps, with an average value of  $\Delta H = 6.4$  gauss/step (see Fig. 7).

The different behaviour of the apparatus at different values of the rate of rise of the measured magnetic field is justified by the fact that the value of the coercitive field in the magnetic material used for the peaking strip, increases from the value of about 7 millioersted in the static case, to a value of 1.2 oersted for fields rising at a rate of  $.1$  gauss/ $\mu$ s, and to a value of 2.2 oersted for fields rising at a rate of  $.3$  gauss/ $\mu$ s.<sup>(7)</sup>

In fig. 8 the amplified pulses from the peaking strip, together with the corresponding steps of the staircase waveform, are shown in an enlarged scale.

In fig. 9 is shown the staircase waveform reproducing a fancy magnetic field produced by injecting a pulse of current in a solenoidal coil. The staircase tracks the current waveform, show in the photograph by the solid curve, with an high degree of accuracy, as is better shown in fig. 10 which is an enlarged part of fig. 9.-

---

(7) These values have been measured by Dr. G. Diambrini-Palazzi, whom we wish to thank for these data.-



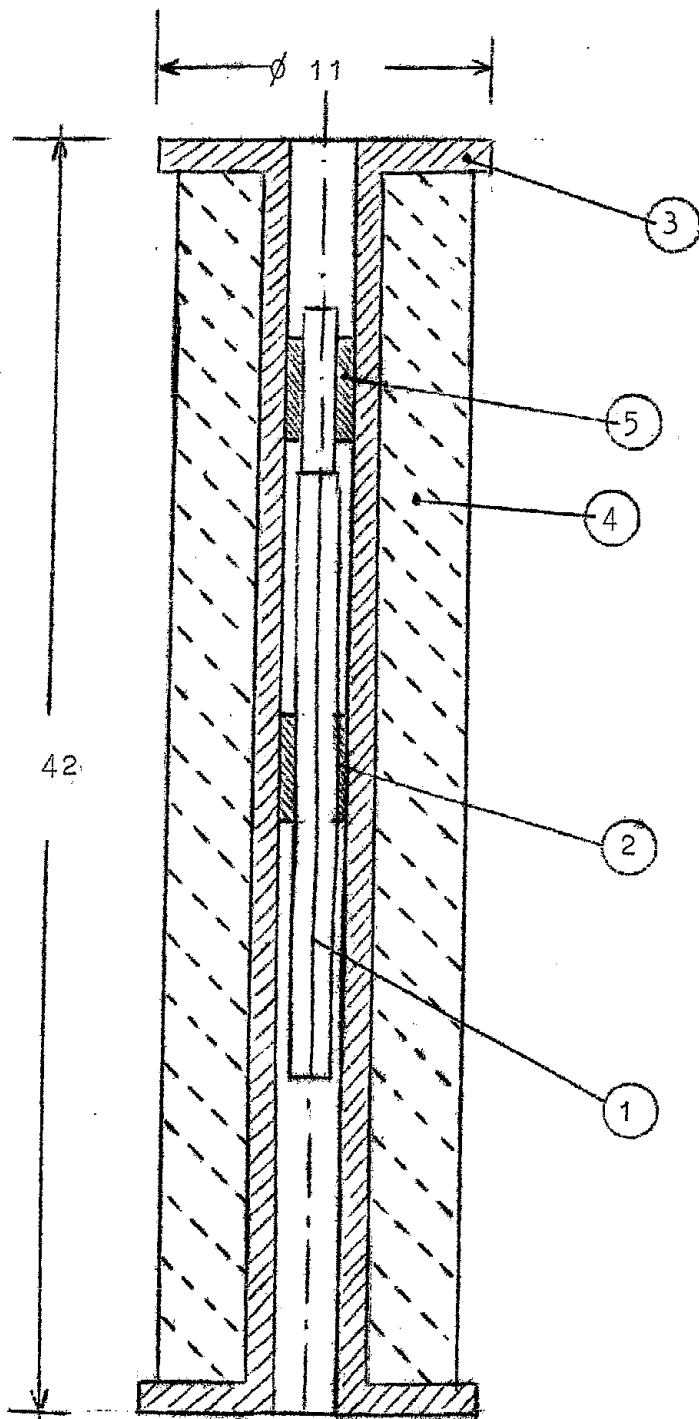

- 1 Ultraperm 10 wire, diameter 0,025 mm  
length 20 mm contained in a quartz tube  
ext. dia. 0,9 mm, int.dia. 0,2 mm
- 2 Pick up coil - 400 turns of enameled  
copper wire of dia. 0,05 mm
- 3 Plexiglass frame
- 4 Bias coil. Copper wire 0,2 mm  
dia. 750 turns/cm
- 5 Compensating coil - sec n. 2

FIG. 1 - MAGNETIC PROBE

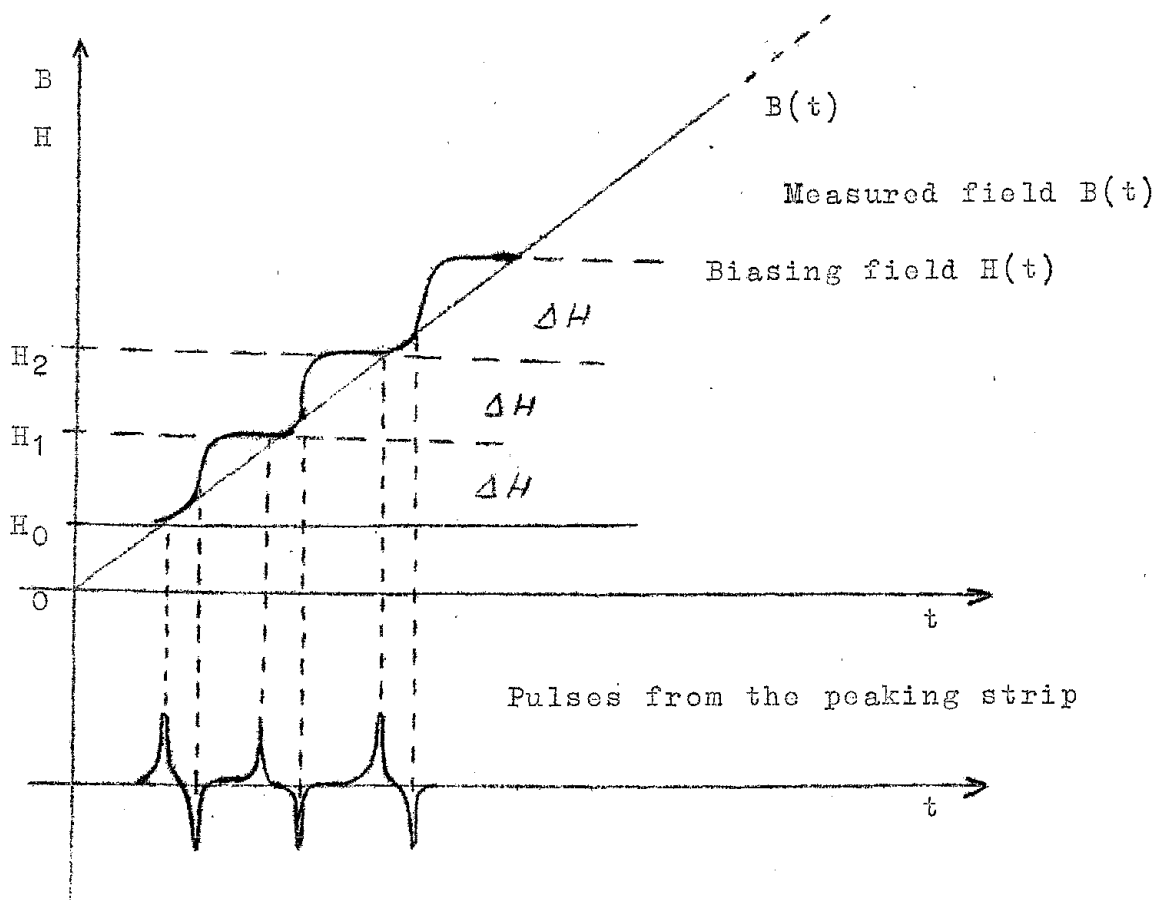

FIG. 2 - DIAGRAMS SHOWING THE PROCESS OF  
 GENERATION OF THE STAIRCASE WAVEFORM.

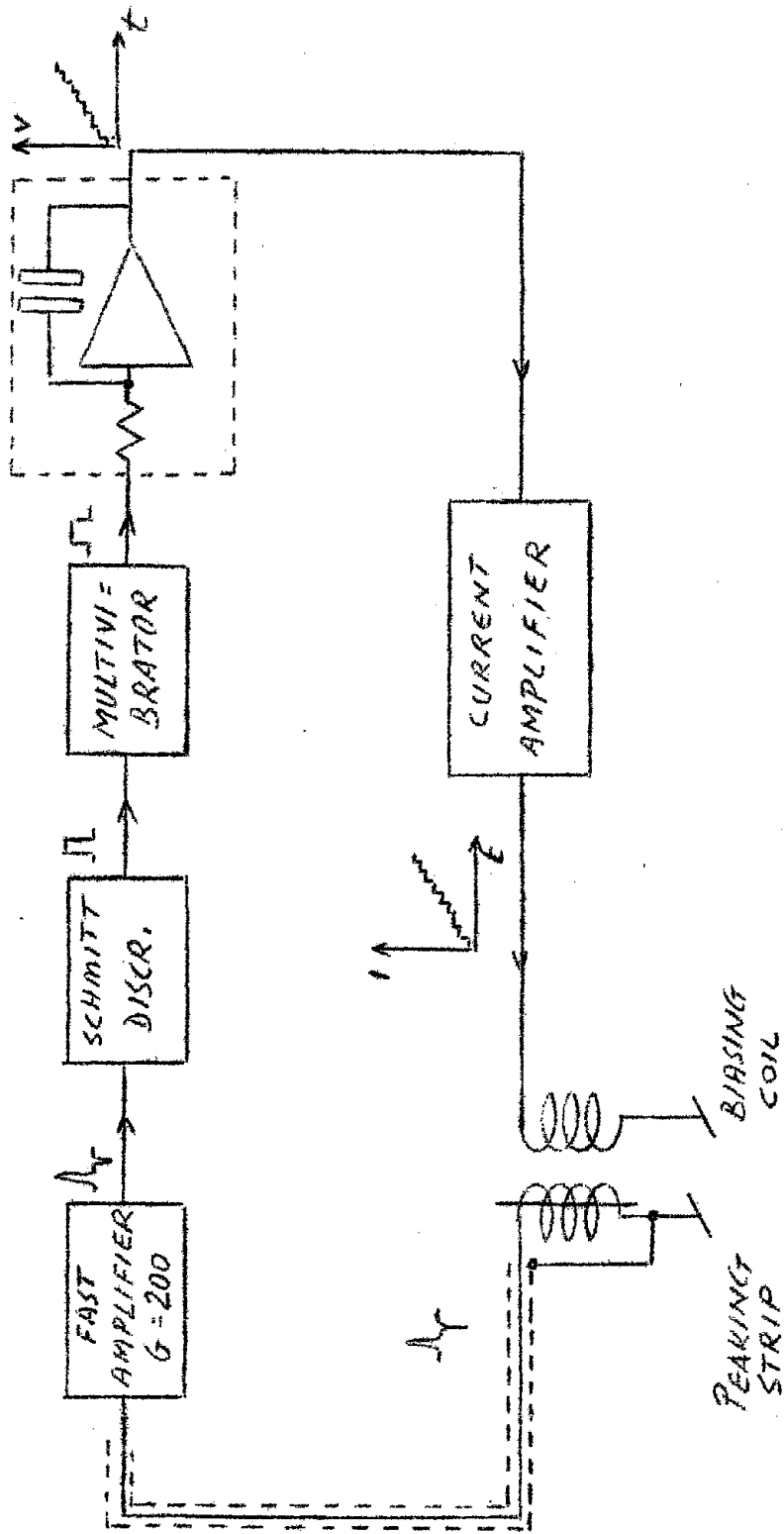
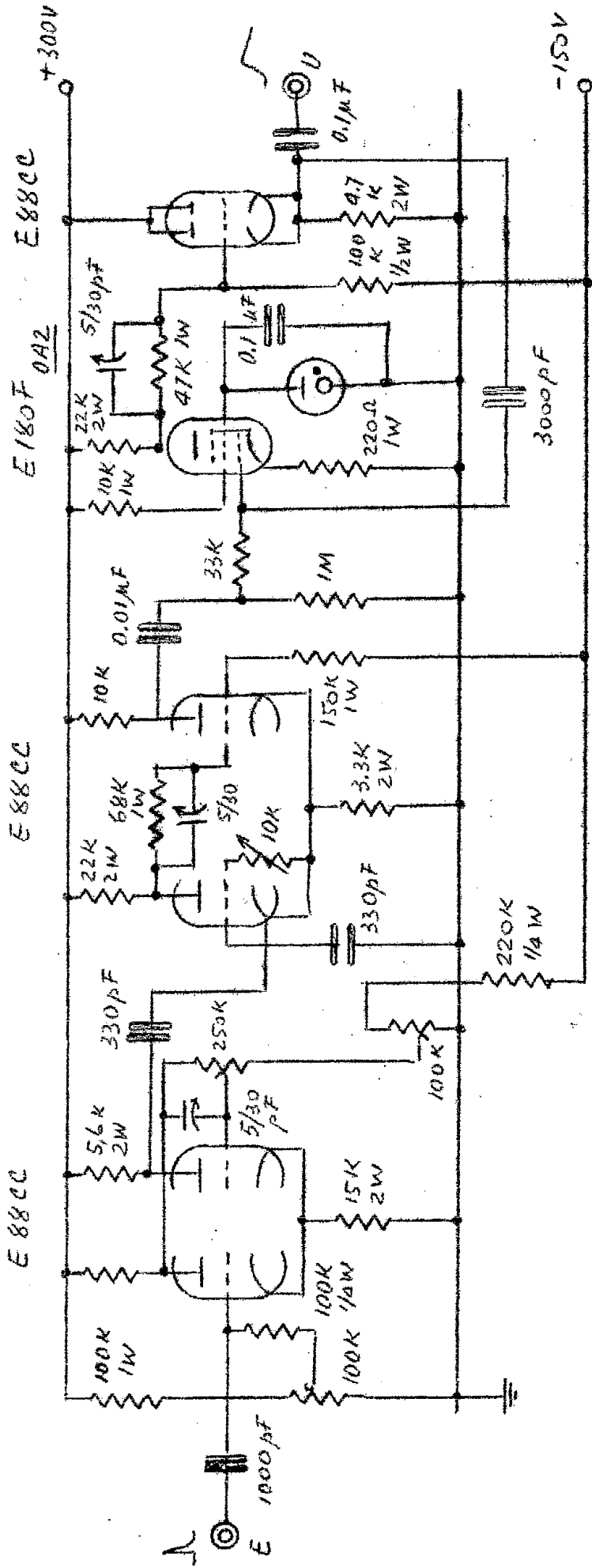

FIG. 3 - BLOCK DIAGRAM OF THE APPARATUS.



INTEGRATOR

MULTIVIBRATOR

SCHMITT DISCRIMINATOR

FIG. 4

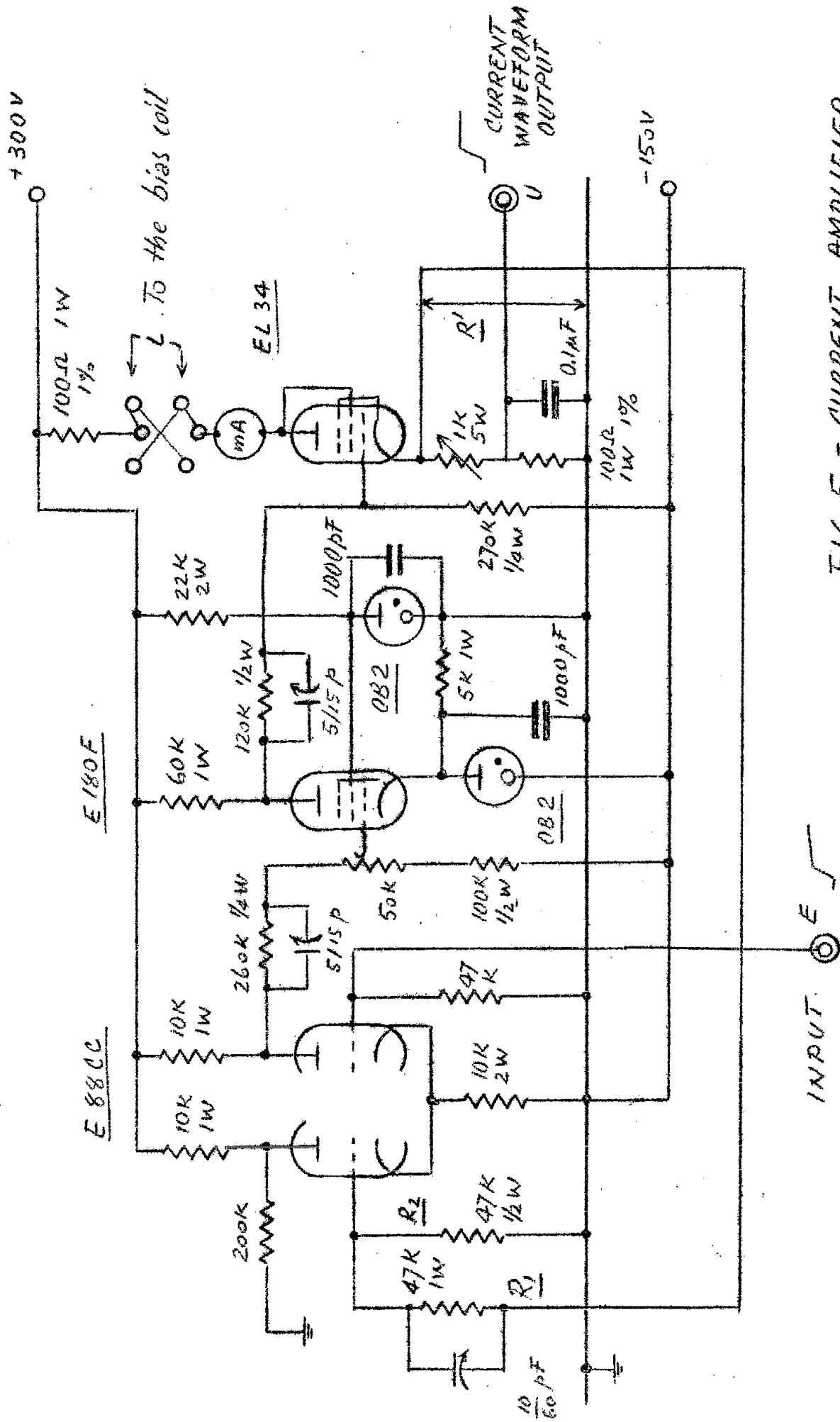
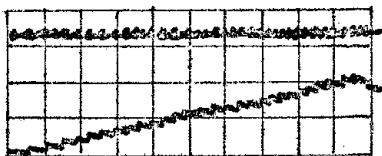

FIG 5 - CURRENT AMPLIFIER

FIG. 6 (sweep length = 1 ms)



Amplified pulses from peaking strip

90 gauss - 29 steps staircase  
 $dB/dt = 0,1 \text{ gauss}/\mu\text{s}$

FIG. 7 (sweep length = 0,5 ms)

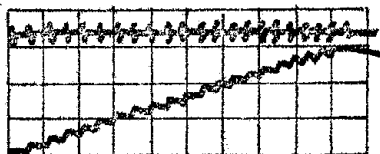

Amplified pulses from peaking strip

90 gauss - 14 steps staircase  
 $dB/dt = 0,3 \text{ gauss}/\mu\text{s}$

FIG. 8 Enlarged scale sweep  $10 \mu\text{s}/\square$



staircase (v.s.  $1 \text{ Volt}/\square = 9 \text{ gs}/\square$ )

pulses (v.s.  $10 \text{ Volt}/\square$ )

FIG. 9 Staircase wave form tracking a magnetic field produced by injecting in a solenoidal coil a current pulse (solid line)  
Vertical scale  $24,6 \text{ gs}/\square$   
Sweep  $1 \text{ ms}/\square$

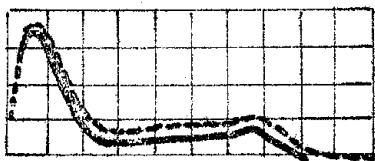

FIG. 10 Same as fig. 9 in enlarged scale  
Vertical scale  $24,6 \text{ gs}/\square$   
Sweep  $200 \mu\text{s}/\square$

