



Istituto Nazionale  
di Fisica Nucleare

# LABORATORI NAZIONALI DI FRASCATI

## SIS-Pubblicazioni

**LNF-09/18(P)**  
December 23, 2009  
CMS Note 2009/52

### CHEMICAL ANALYSES OF MATERIALS USED IN THE CMS RPC MUON DETECTOR

S. Bianco<sup>1</sup>, S. Colafranceschi<sup>1,2,3</sup>, D. Colonna<sup>1</sup>, M. Giardoni<sup>1</sup>, F. Felli<sup>2</sup>,  
T. Greci<sup>2</sup>, A. Paolozzi<sup>1, 2</sup>, L. Passamonti<sup>1</sup>, D. Pierluigi<sup>1</sup>, C. Pucci<sup>2</sup>,  
A. Russo<sup>1</sup>, G. Saviano<sup>2,\*</sup>, M. Abbrescia<sup>4,5</sup>, R. Guida<sup>3</sup>

<sup>1)</sup> *INFN Laboratori Nazionali di Frascati, Via E. Fermi 40, I-00044 Frascati, Italy*

<sup>2)</sup> *INFN Laboratori Nazionali di Frascati, Via E. Fermi 40, I-00044 Frascati, Italy  
and Università degli Studi di Roma "La Sapienza", Piazzale A. Moro*

<sup>3)</sup> *CERN CH-1211 Genève 23 F-01631 Switzerland.*

<sup>4)</sup> *INFN Sezione di Bari, Via Amendola, 173I-70126 Bari, Italy*

<sup>5)</sup> *Dipartimento Interateneo di Fisica, Via Amendola, 173I-70126 Bari, Italy*

*\*) Corresponding Author*

#### Abstract

Results are reported on a study of materials used in the CERN Closed Loop recirculation gas system presently under test with the RPC muon detectors in the CMS experiment at the LHC. Studies include a sampling campaign in a low-radiation environment (cosmic rays at the CERN ISR test site). We describe the dedicated RPC chamber tests, the chemical analysis of the filters and gas used, and discuss the results of the Closed Loop system.

PACS: 95.55.Vj; 29.00.00 ; 61.80.-x ; 29.40.Cs

*Submitted to JINST*

## 1 Introduction

Resistive Plate Counters [1] (RPC) are used in the muon detector of the Compact Muon Solenoid (CMS) experiment [2] at the CERN Large Hadron Collider. The constituent elements of RPCs are two parallel electrode, high-resistivity bakelite plates between which, in a 2 mm gap, a gas mixture at ordinary pressure is circulated. A 9.0-10.0 kV voltage drop is applied between plates. RPC use fluorine-based gas mixture whose main component is Freon. Because of the high cost of Freon and the very large gas volumes involved in the full system, the design of the CMS RPC gas system is based on a recirculation system called the Closed Loop (CL) system.

The absence of gas contaminants is of paramount importance in all gas detectors, and especially in RPC due to the high reactivity of the F-based gas mixture used [3] [4]. A gas gain monitoring system [5][6][7] has been designed, built and is being commissioned by the CMS RPC group for the fast monitoring of the working point, based on the monitoring of the avalanche charge and of the chamber efficiency. The gas gain monitoring system is based on three single-gap RPC subdetectors flushed with clean mixture, CL mixture after purifiers before crossing CMS RPC, and CL mixture from the return lines. The gas gain monitoring will provide a warning in case of a working point change. A gas quality monitoring system is being developed by the CMS RPC group which will perform chemical analyses such as Gas Chromatography (GC), High Pressure Liquid Chromatography (HPLC), pH meters, etc. following the release of a warning condition.

No aspect of the chemistry of purifiers used in CL is fully understood, nor the extent or the nature of contaminants with the exception of fluoridric acid, whose presence is established. Tests [8][9] at the Gamma Irradiation Facility (GIF) [10] showed the presence of HF, which is detected by accumulation methods or by the use of HPLC, or ionic column-equipped GC. We have proposed[11] a systematic investigation aimed to fully clarify the chemistry of purifiers used in the CL, structured in three phases. Purifiers and filters were firstly studied at the ISR test area during chamber testing with cosmic rays (phase one). At completion of ISR chamber testing, new RPC detectors dedicated to contaminant studies will be deployed (phase two). The system behavior will be studied by allowing currents to increase under production of contaminants. Finally, high-radiation environment and contaminants will be studied at the CL at the GIF facility (phase three). Results [12] [13] reported on in this paper refer to phase one which took place in September 2006.

## 2 The Closed Loop system

The CMS Closed Loop (CL) [2][14][15] gas system is shown in Fig. 1. The basic function of the gas system is to mix the different gas components in the appropriate proportions and to distribute the mixture to the individual chambers. The large detector volume and the use of a relatively expensive gas mixture make a closed-loop circulation system mandatory. The system consists of several modules: the primary gas supply, mixer and closed-loop circulation system, gas distributors to RPC chambers, purifier, pump, and gas-analysis station. In the CL system, gas purity is guaranteed by a multistage purifier system. The full closed-loop circulation system extends from the surface gas building SGX to the USC55 service cavern and UXC55 experimental cavern.

Tests with a scaled-down prototype CL system (Fig. 2) were performed in 2001 at the GIF[8][9] with the aim of selecting the purifier materials. Purifier materials were selected such that contaminants components (appearing as spurious peaks in a GC other than the mixture known gases) were minimized. The purifiers selected were zeolite molecular sieve[16], BASF CuO-ZnO catalyst (R3-12) [17], BASF CuO (R3-11G)[17], LEUNA NiAlO<sub>3</sub> catalyst[18]. The absorption capacity for the various contaminants was not studied.

In the study described in this paper, results on characterization of filter materials following an analysis campaign carried out at the prototype CL installed are reported. The prototype CL (Fig. 2) is composed of mixer, purifiers, recirculation pump and distribution to RPC detectors. Each RPC detector is composed of two gaps (upstream and downstream) whose gas lines are serially connected. RPC detectors are operated at a 9.2 kV power supply. The anode dark current drawn because of the high bakelite resistivity is approximately (1-2)  $\mu$ A. Gas sampling points before and after each filter in the closed loop allow to sample gas for chemical and gaschromatograph analysis. While the fraction of fresh gas planned for use at the full CMS RPC detector is 2%, the clean gas mixture fraction used for this study is 10%.

Purifier material was used over several regeneration cycles (see § 3 for regeneration procedure). Water saturation of filters occurred after about twenty days, followed after a few days by an increase of the dark current drawn across the bakelite gap. (Fig. 3). Dark currents of the upstream detector are observed rising much more than dark currents in the downstream detector as shown in Fig. 3 a). Such a behavior is consistent with the presence of one or more unknown contaminants generated by both detectors, that accumulate in the upstream detector which acts as a filter. Contaminants are removed by purifiers as long as not saturated with water. Replacing and regenerating filters after about 25 days allows operation of the CL without dark currents increase in the RPC detectors. A best fit of an

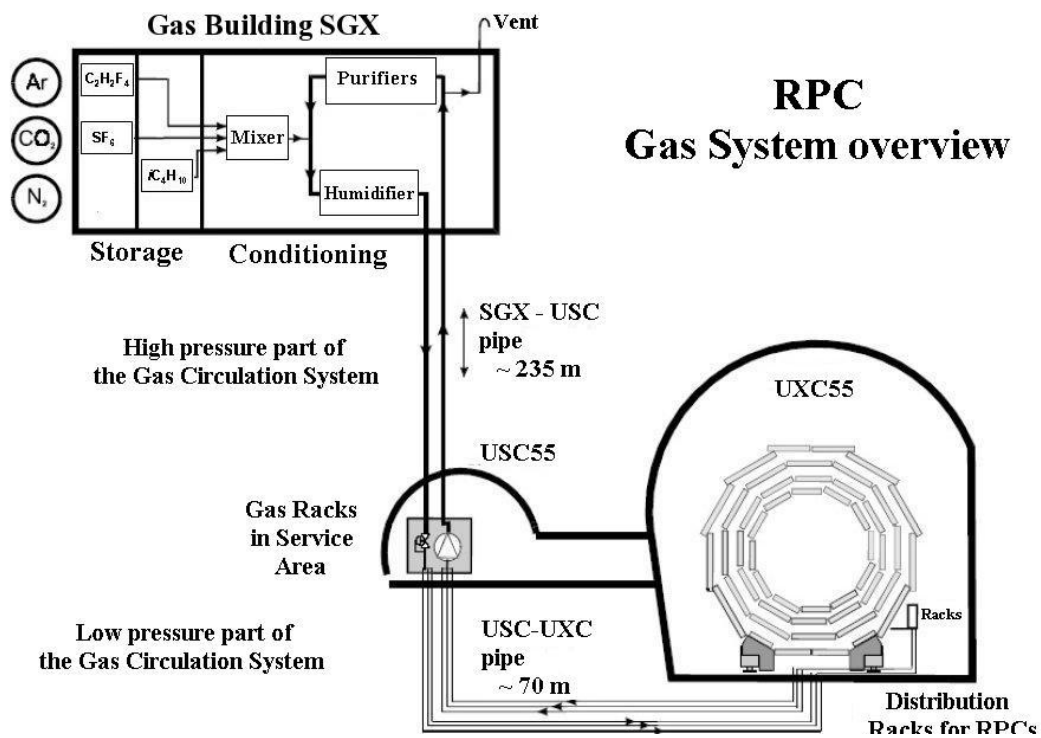

Figure 1: The CMS RPC Closed Loop recirculation gas system.

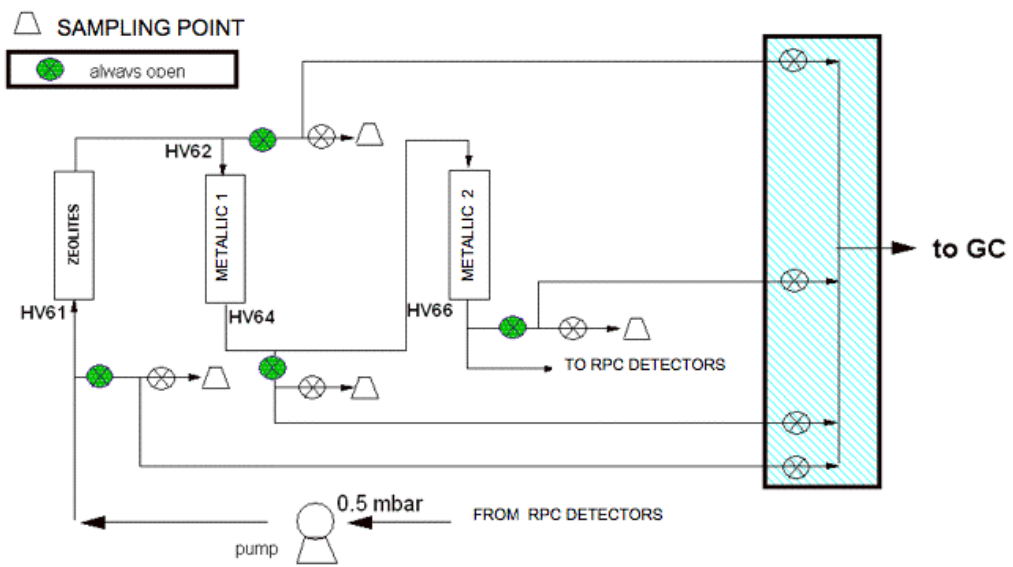

Figure 2: The scaled-down prototype Closed Loop system.

exponential curve to data points (Fig. 3 b) yields a  $1.0 \pm 0.4$  days dark current rise time, while the fall time is  $2.6 \pm 0.3$  days.

### 3 Filters

With the original selection criteria being the filtering of H<sub>2</sub>O and O<sub>2</sub>, tests at GIF showed GC peaks of unknown pollutants that disappeared after the following purifiers

- purifier 1. consisting of a 24-litre cartridge filled with 5Å Type molecular sieve manufactured by ZEOCHEM
- purifier 2: consisting of two 24-litre cartridges, each filled with a combination of:
  1. 25% Cu-Zn filter type R12 manufactured by BASF
  2. 25% Cu filter type R3-11G manufactured by BASF
  3. 50% Ni AlO<sub>3</sub> filter type 6525 manufactured LEUNA

The filters studied in this paper are described in Appendix I. The regeneration procedure consisted of the heating at 240°C in a H<sub>2</sub>/Ar (7/93) flux of 100 liters/hour for 16 hours, followed by a 2-hour cleaning with Ar.

Unused, contaminated and regenerated purifiers were sampled, and chemical analyses performed for major and trace elements, as well as for sulphur and carbon (graphitic, total and organic), Ionic Chromatography (IC) to analyze fluorine, XRD analyses to identify zeolite type and to evaluate a possible crystalline structure of compounds, possibly occurring after gas filtering. The aims of these analyses were to characterize contaminants in filters, to identify their form (crystalline, in solution, amorphous), and to define the filters composition after regeneration. A brief description of the analysis methods used is given in Appendix II.

The zeolite grain size and diffractometric pattern was studied. We found that the molecular sieve material consisted of a mixture of a 5Å type and a 3Å type zeolite, with the 5Å sample being measured with a grain size in the range of 2.0 mm to 2.8 mm, and the 3Å sample with a grain size in the range of 1.0 mm to 1.4 mm. Following these findings filters were opened, and filter material completely replaced with unused material. The composition of the filters used for the measurements reported in this paper is 100% molecular sieve 5Å type. We performed a XRD of the unused 5Å molecular sieve material and compared it with existing data. The unknown compound well matches zeolite LINDE Type A.

An increase of trace elements in filters after operation and regeneration is observed. In zeolite molecular sieve, Cu, Ni and Zn increase after purification and only partially

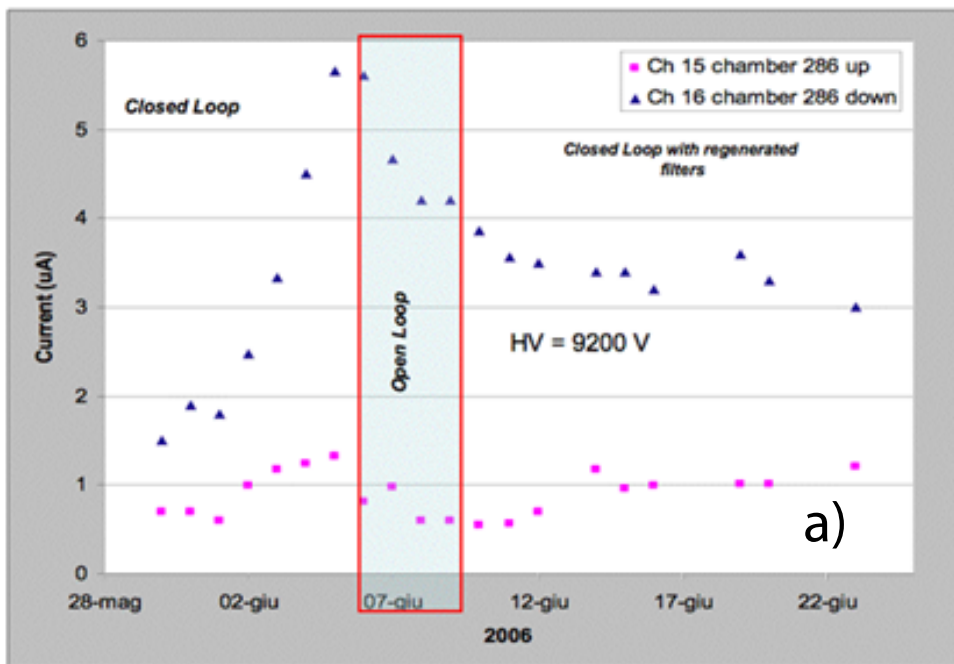
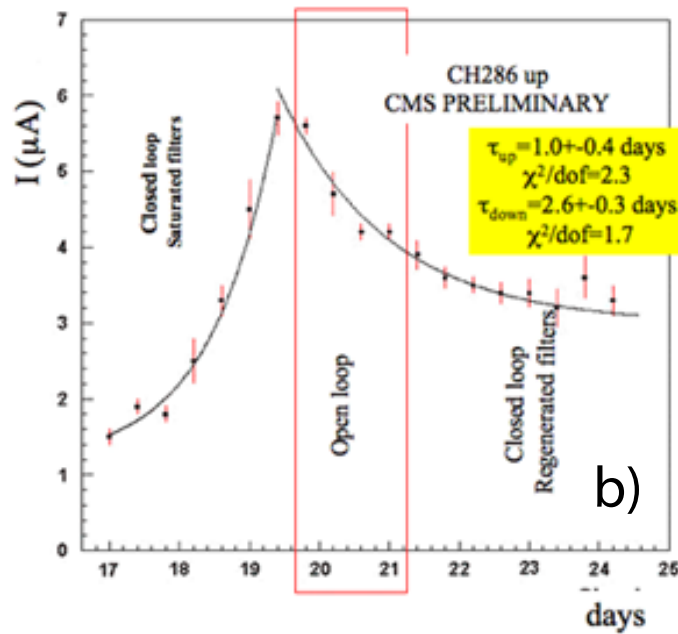

Figure 3: (a) Increase of dark current in RPC chambers under test at the ISR in CL gas system when purifiers are saturated. Dark current starts decreasing when chamber is set in Open Loop, and decrease further when chamber is returned to CL with regenerated purifiers. (b) Results of a best fit of an exponential curve to data.

are removed after regeneration (Fig. 4), and this is also shown for the same for F and S (Fig. 5) and major elements (Fig. 6).

The zeolite molecular sieve filters not only  $H_2O$ , but also trace elements leached during the gas flux from the CL system. At this stage of purification, the zeolite acts as a buffer and pH of gas mixture increases from pH 4.9 to pH 6.0.

Analyses of LEUNA 6525 Ni-Al purifier show a decrease of Cr, Cu and Zn after purification, and only a partial recover of these elements after regeneration, i.e., Cr, Cu and Zn are released in the system and they are not completely recovered after regeneration (Figs. 7, 8). F and S increase after filtration in the LEUNA filter, but are not removed after regeneration (Fig. 9).

In the R3-12/R3-11G filter the F and S are trapped but not released after regeneration (Fig. 10). Substantial issues are raised by regenerating the R3-12 purifier, which is declared not regenerable in datasheet. R3-12 filter is usually used for removing traces of arsine, phosphine, COS,  $H_2S$  from vapor or liquid phases. Such components form CuS and ZnS sulphides which neither migrate nor desorb off of the catalyst. S is present in the gas mixture as  $SF_6$ , and if released, S could bind with Cu and Zn in a sulphide form. This is confirmed by the Ni-based LEUNA purifier high S content, which remains in purifier even after regeneration.

Finally, both metallic filters release a very fine dust residue. We checked on the technical specs and the presence of graphite is confirmed. Particulate filters ( $20\ \mu m$ ) should be installed.

## 4 Gas

The gas mixture used is 95.2% of  $C_2H_2F_4$  in its environmental-friendly version R137a, 4.5% of  $iC_4H_{10}$ , and 0.3%  $SF_6$  to suppress streamer and operate in saturated avalanche mode. Gas mixture is humidified at the 45% RH level typically to balance ambient humidity, which affects the resistivity of highly hygroscopic bakelite, and to improve efficiency at lower operating voltage. The CL is operated with a fraction of fresh mixture continuously injected into the system. Baseline fresh mixture fraction for CMS is 2%, the test CL system was operated at 10% fresh mixture.

The strategy adopted for the gas analysis was to search for elements likely released by filters, i.e., metals, Na, K and Ca in first priority. No previous study existed, therefore a very broad spectrum of metallic elements was searched for. Gas samples were taken by bubbling gas mixture in  $H_2O$  at four sampling spots of CL, namely clean mixture (YV10), after RPC detectors and before the zeolite filter (HV61), after zeolite filter (HV62) and after metallic filters (HV66) for a total of approximately 20 days and a total volume of



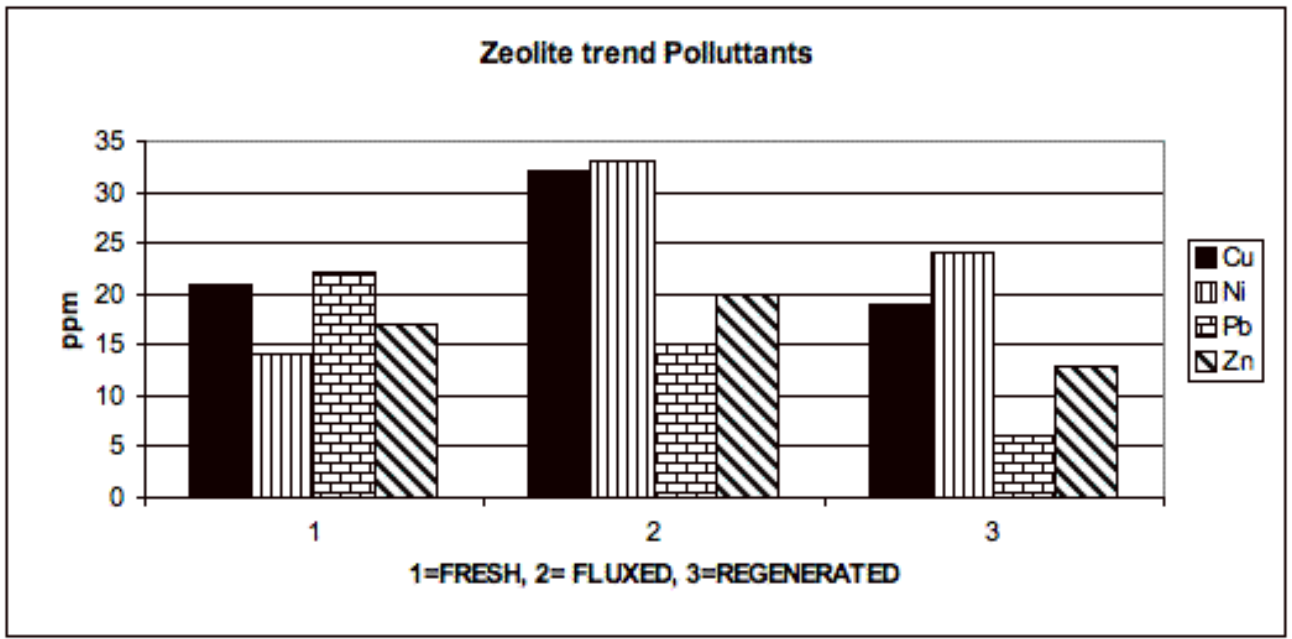

Figure 4: Zeolite trace elements trend (Cu, Ni, Pb, Zn)

1 m<sup>3</sup>. Water solution was analyzed at HPLC.

Gas analysis in sampling points downstream of zeolite filters show Ca content increase in gas mixture, probably released by the 5Å Ca zeolite type during filtration. Results also show presence of metals and F<sup>-</sup> in gas mixture (Figs. 11, 12, 13). The pH of gas mixture was monitored, finding confirmation for a buffering action of zeolite from pH 4.5 to pH 7 (Fig.14).

## 5 Bakelite

The material used for the containers of gas volume in CMS RPC detectors (called *bakelite*) is a plastic laminate obtained by wetting paper sheets with several kinds of resins. As such, bakelite is composed of many elements. Plastic laminates are produced by using mainly melaminic and fenolic resins. For the RPC detectors, a laminate [19] composed of a bulk of paper wet by fenolic resin was used, surrounded by two outer layers of paper wet by melaminic resin, up to a 2 mm thickness. In CMS RPC detectors, the outer layer of the bakelite sheet exposed to the gas mixture is coated with linseed oil [21].

To study the effect of gas mixture on bakelite, samples of pure unoiled bakelite (sample A) and of oiled bakelite (sample B) were taken from a RPC detector irradiated at the GIF [9]. The RPC was fluxed with the standard CMS RPC gas mixture in Closed

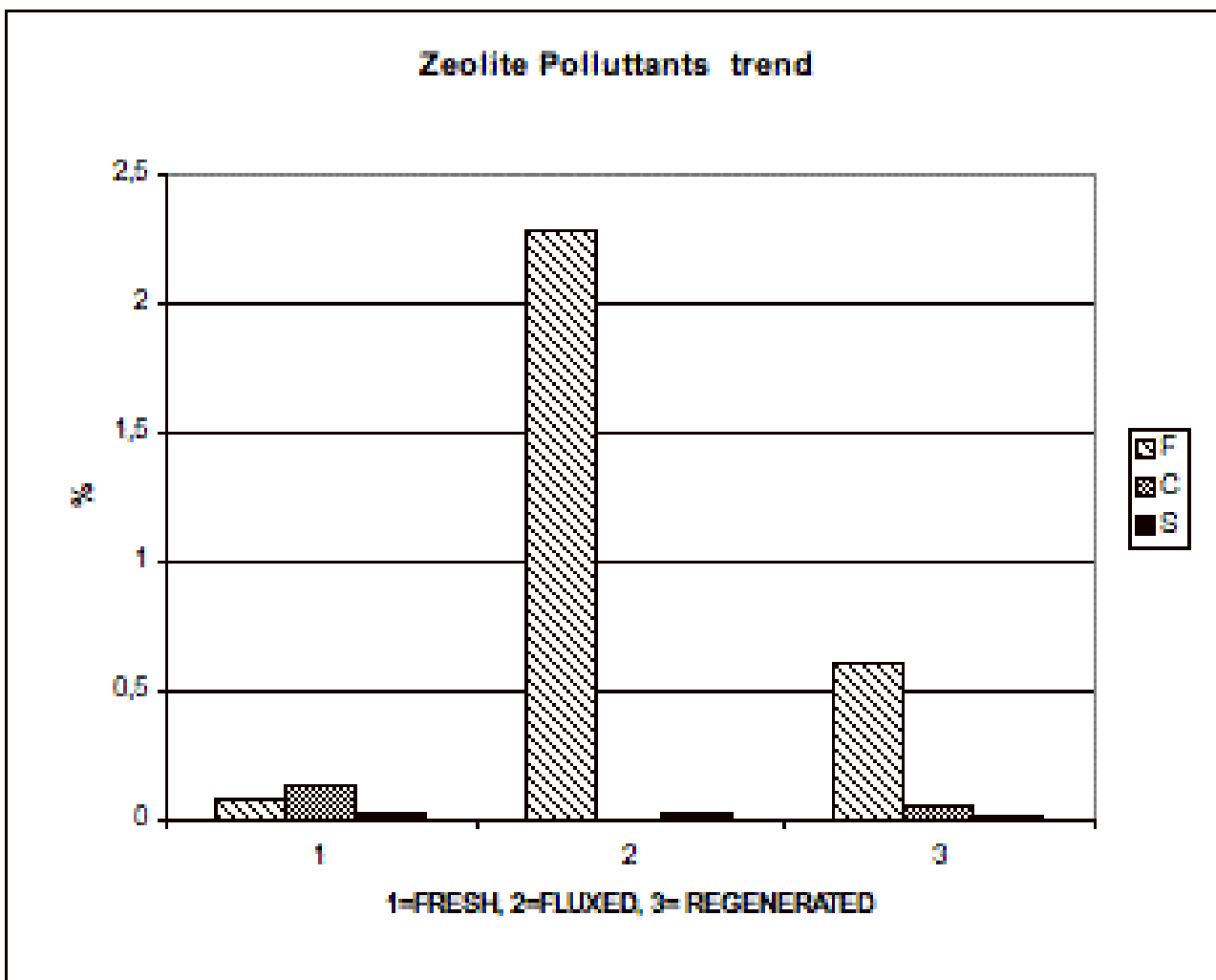

Figure 5: Zeolite trace elements trend (F, S, C).

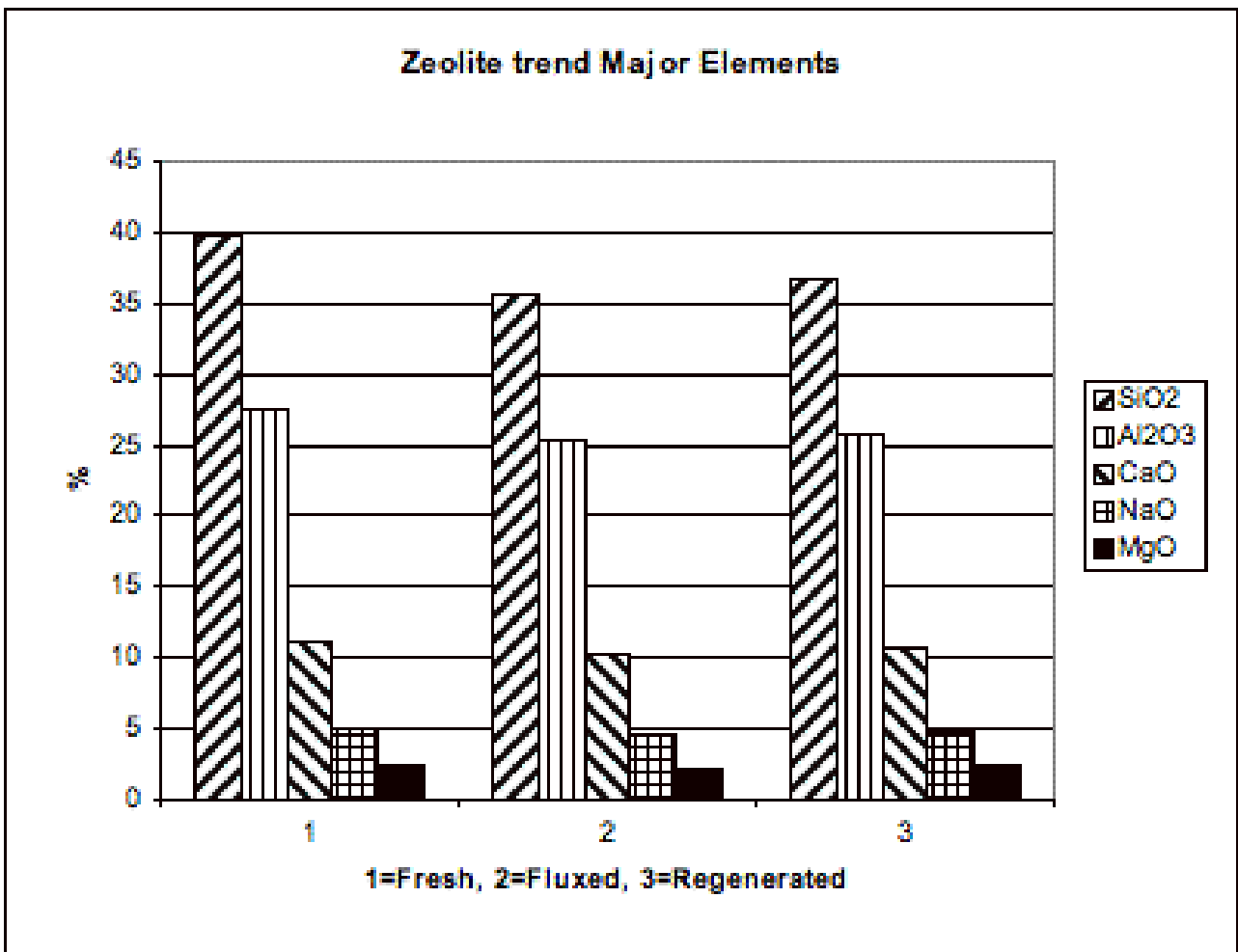

Figure 6: Zeolite major elements SiO<sub>2</sub>, Al<sub>2</sub>O<sub>3</sub>, CaO, NaO, MgO.

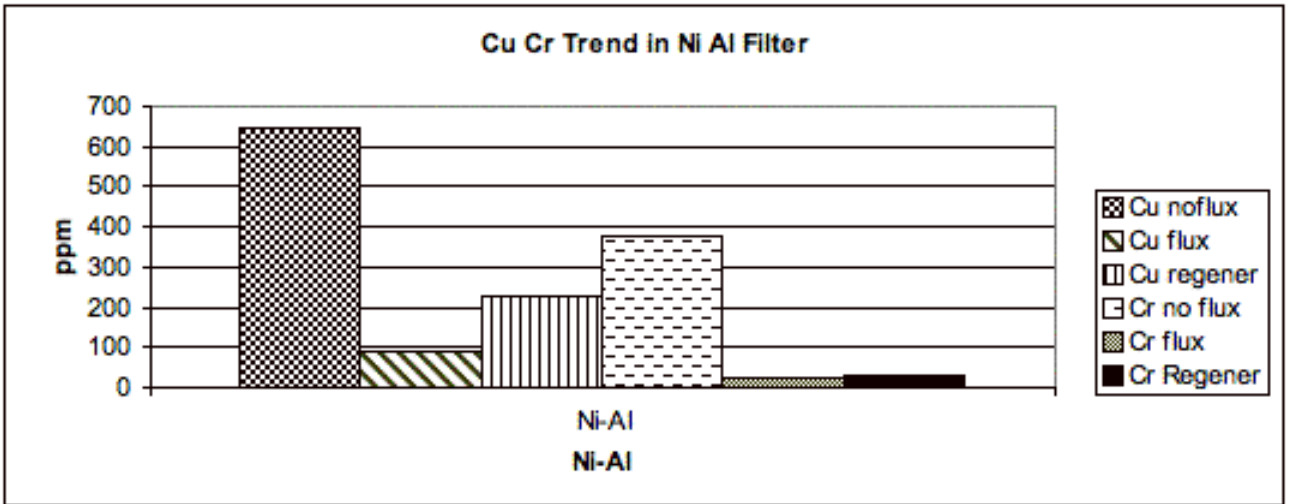

Figure 7: Ni-Al filter (Cu, Cr).

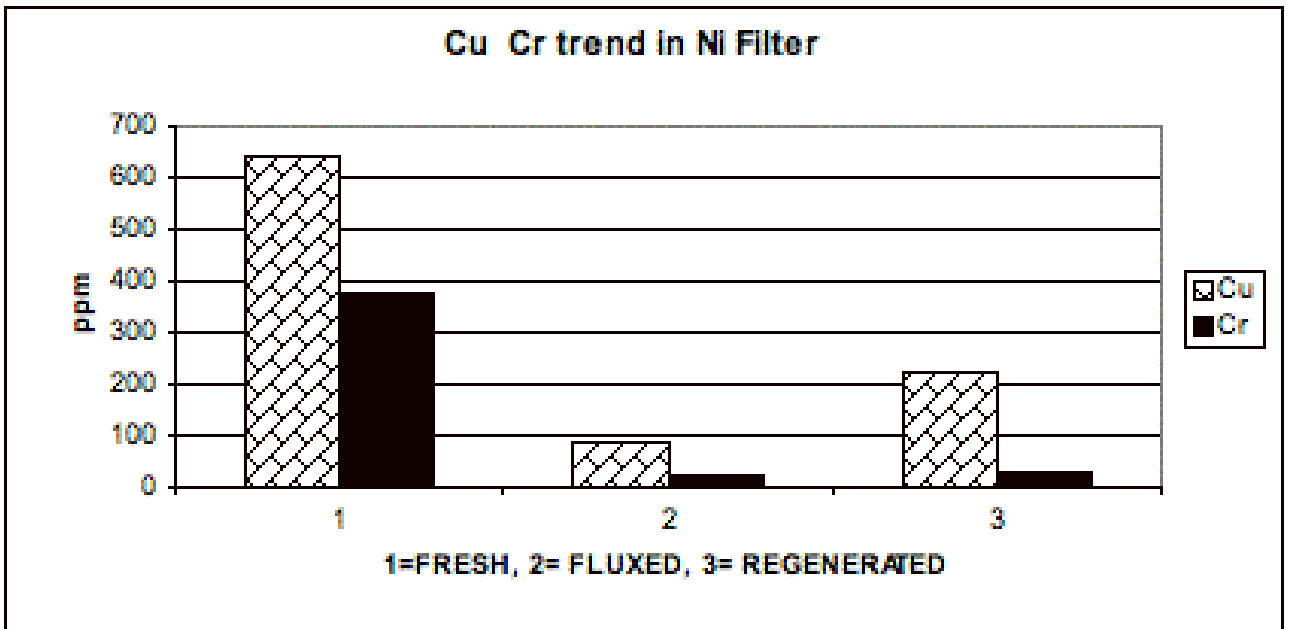

Figure 8: Ni filter (Cr, Cu).

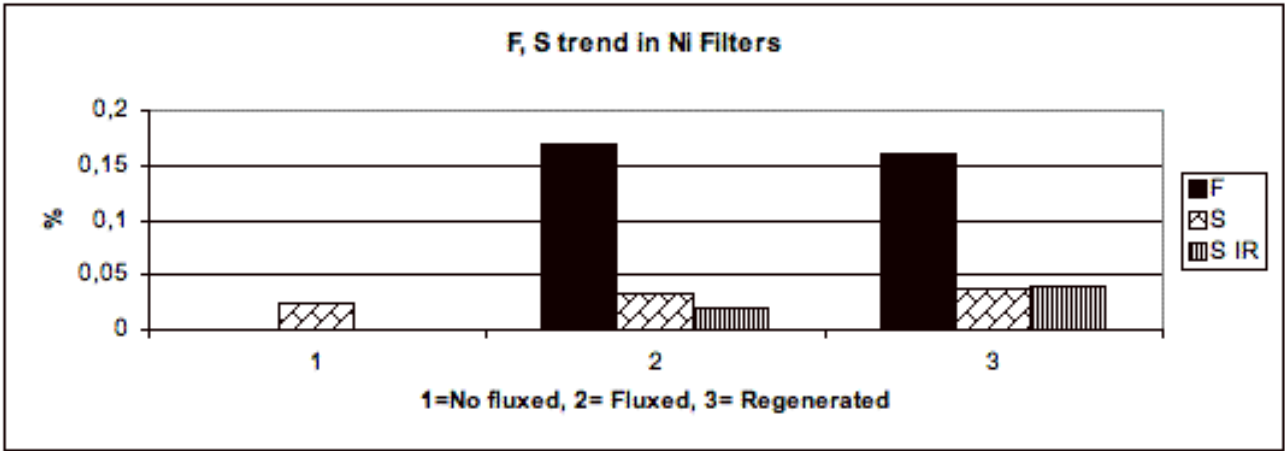

Figure 9: Ni filter (S-IR, S-TD/ICP, F).

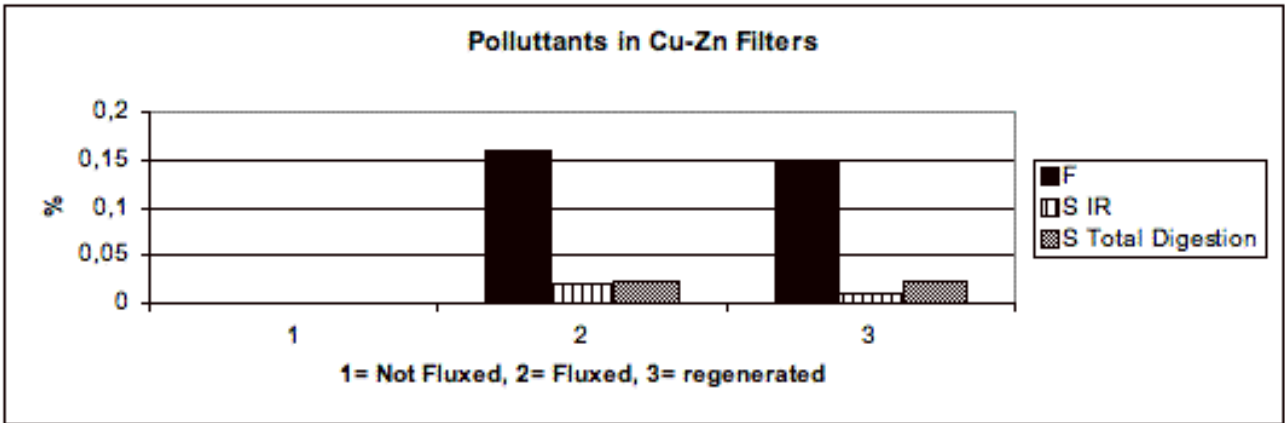

Figure 10: Cu-CuZn filters (S-IR, S-TD/ICP, F).

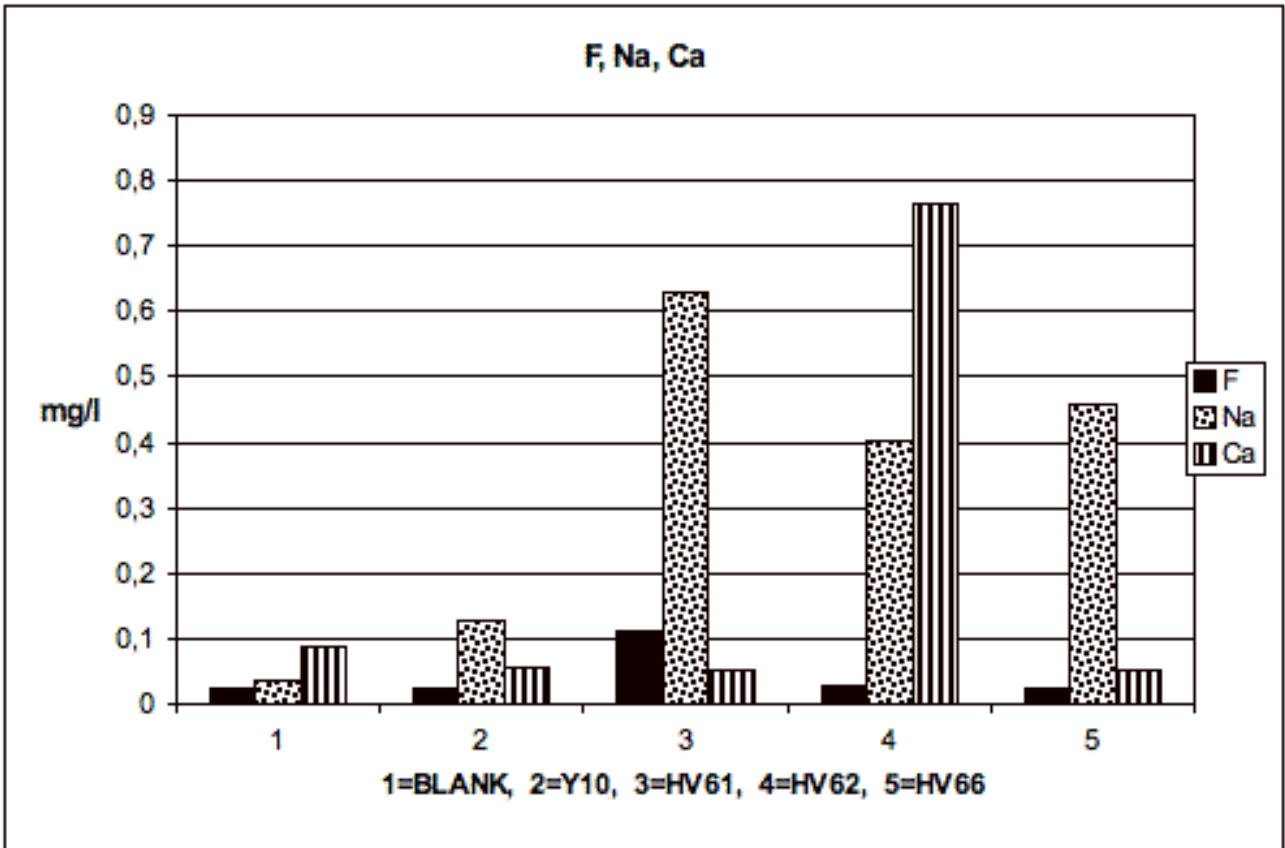

Figure 11: Gas concentrations F, Na, Ca.

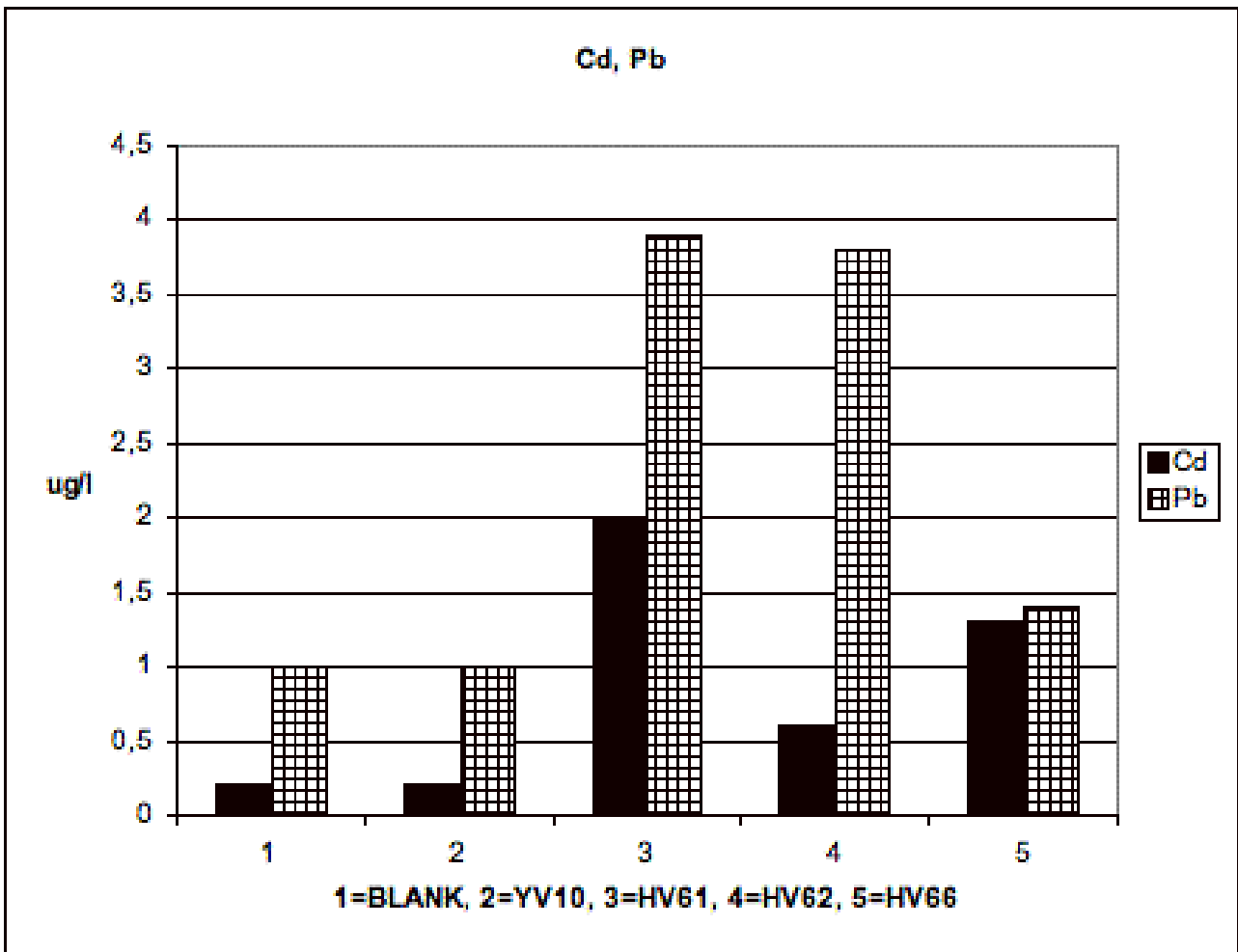

Figure 12: Gas concentrations Cd Pb.

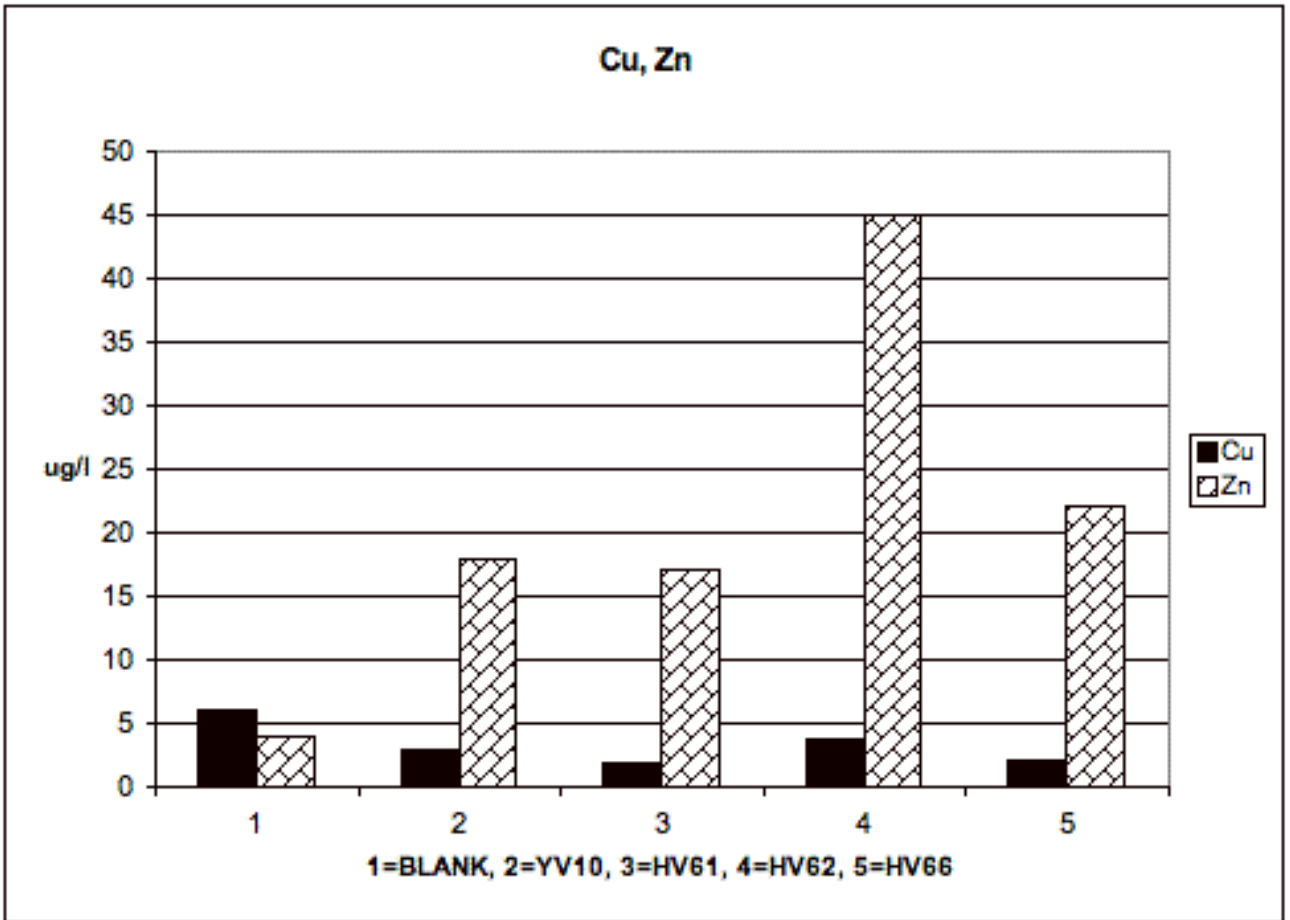

Figure 13: Gas concentrations Cu Zn.



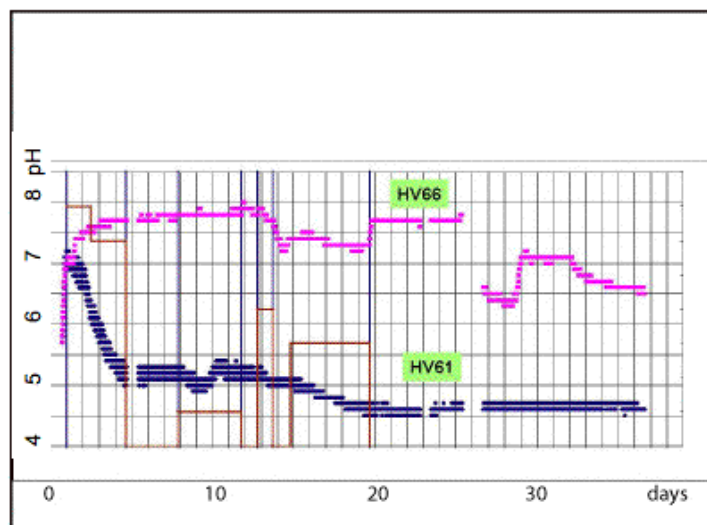

Figure 14: pH of gas mixture sampled before purifiers (HV61) and after all purifiers (HV66).



Figure 15: Large RPC chamber (2 m × 1 m) exposed at GIF with defects and oil drippings.

Loop, and irradiated by a  $^{137}\text{Cs}$  radioactive source at a total dose of 650 GBq.

To avoid the production of bakelite debris, the RPC was open by blowing air until the spacer detachment. Fig. 15 shows the inner surface (linseed-oil coated bakelite) of an open RPC detector: spacers, linseed oil drippings and white defects are visible.

After separating the anode and cathode plates, defects have been marked on the bakelite inner surface. The defect areas of interest have been protected by adhesive guard rings to avoid the production of bakelite debris. A slow-motion drill with a 4 cm-diameter tap was used to sample discs for SEM analysis. Bakelite samples have been catalogued as Centre-Cell (CC) (undefected samples among spacers), Defect (D) where defects appear at visual inspection, and Manina (M) for areas close to spacers with linseed oil dripping.

SEM-EDS analysis was performed on unused, unoiled bakelite samples (sample A), and on unused, oiled bakelite (sample B). Both samples A and B are unused, i.e., never fluxed with gas mixture, and are considered reference samples. Average composition of samples A and B is shown in Figs. 16,17: SEM-EDS distributions are very similar, since bakelite and linseed oil are composed of the same principal atomic components. The N peak is consistent with the presence of melaminic resin in the outer bakelite layer. The composition of two fluxed bakelite samples from 50cm x 50cm RPCs exposed in open loop (sample CC and sample D) is shown in Figs. 18,19. The F peak is prominent, as well as the higher intensity of the Na peak, and the disappearance of the N peak. The defect areas are an erosion of the melaminic outer layer which allows one to access

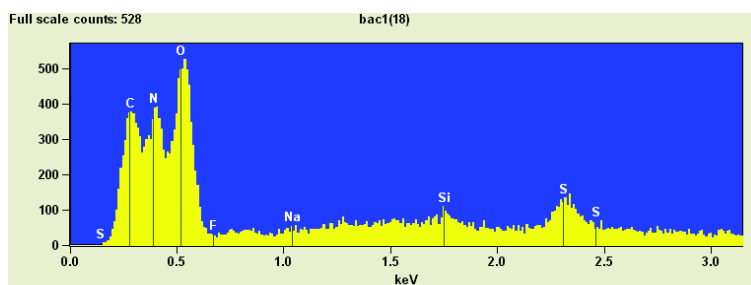

Figure 16: SEM-EDS of unused, unoiled bakelite (A).

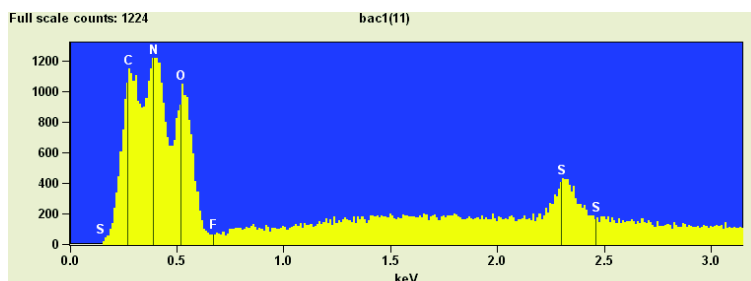

Figure 17: SEM-EDS of unused, oiled bakelite (B).

the composition of the inner fenolic layers, where N is absent. The presence of Na is explained with NaOH used as catalyzer in polymerization of resin, in amounts less than 1% for resin and less than 0.02% on the final product [19][20], as also suggested by similar results [8].

Observation under stereomicroscope of defected areas showed their 3D morphology (Fig. 20). Analyses at SEM-EDS allowed a study of composition of defect areas on a bakelite cross-section. Results showed the presence of Na and F, presence confirmed by SEM-EDS analysis of bakelite cross-section (Fig. 21).

Samples of defected areas were also analyzed at XRD. The diffraction spectrum of defected bakelite shows two high-angle peaks which match the standard peaks of NaF (Fig. 22 top). The same peaks are not observed in the diffraction spectrum of undefected bakelite (Fig. 22 bottom). This measurements constitutes the first observation of the NaF crystal structure for defects in bakelite of RPC detectors exposed to high radiation environment.

Chemical analyses have been performed to characterize bakelite composition of the trace elements. Trace elements may change depending on the production of bakelites.

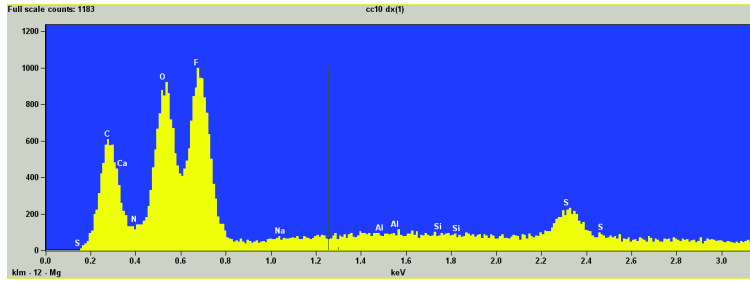

Figure 18: SEM-EDS of bakelite used, oiled centre-cell bakelite (CC).

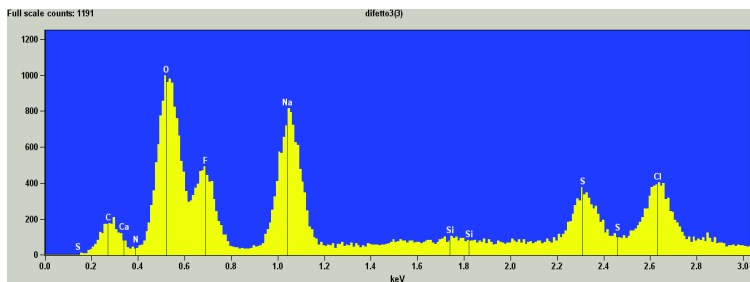

Figure 19: SEM-EDS of bakelite defect (D).

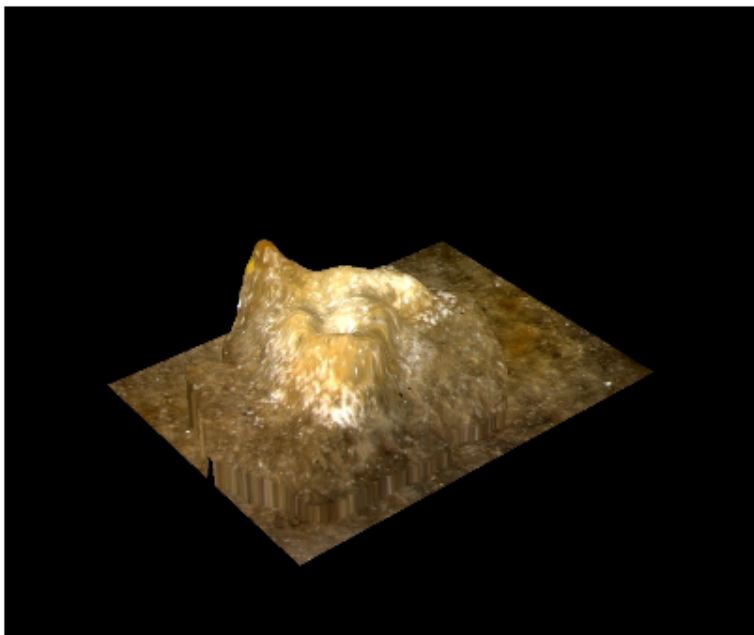

Figure 20: Macrophoto of defect.

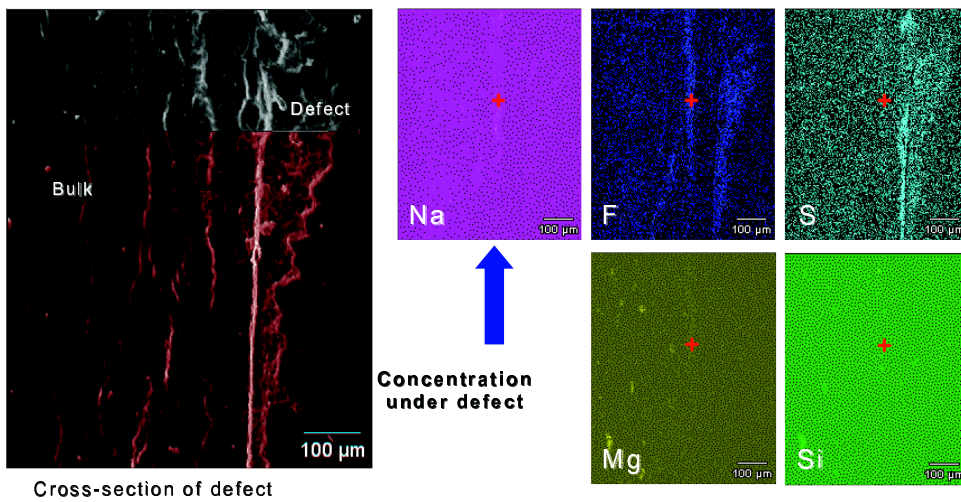

Figure 21: Cross-section of bakelite defect.

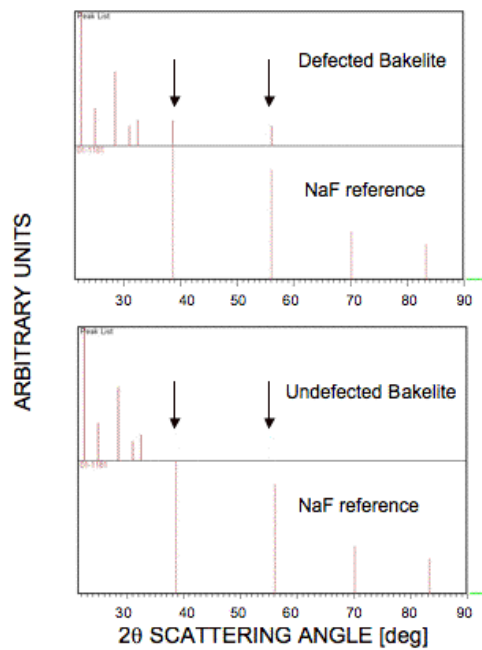

Figure 22: XRD spectrum showing NaF structure of defects. Arrows show the two peaks in defected bakelite characteristic of NaF, absent in undefected bakelite.

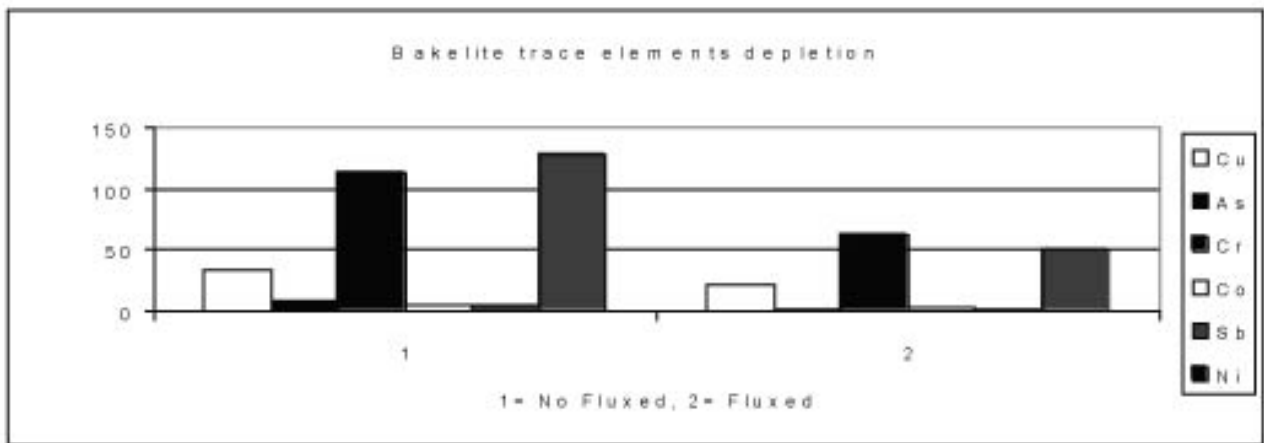

Figure 23: Bakelite concentrations (Cu, As, Cr, Co, Sb, Ni).

Fluxed and nonfluxed bakelites have been analyzed, results are shown in Fig. 23,24, several minor components are depleted in fluxed bakelites. A leaching effect is argued for Ni, Cr, Cu, As, Sb, that are therefore released in the system and in the RPC chambers. Sulphur is also depleted.

## 6 Conclusions and outlook

The purifiers presently used were selected originally in order to filter out H<sub>2</sub>O and O<sub>2</sub> while, given the gas mixture reactivity and the low pH, trace elements are released from purifiers and sent to the CL. The purifiers R3-12 and R3-11G are officially used to remove S and As from vapor or from solutions. Since the gas mixture used contains S, a part of it will interact with the filters depositing sulphides which will stay in the filters. Filters release trace elements naturally present in their unused composition (i.e., Cu and Cr in Ni-based filters). Ni-based filters trap S, very easily bound to Ni as a sulphide, which is not removed after regeneration.

Ni-Al<sub>2</sub>O<sub>3</sub> filters release Cu and Cr during purification. They capture F and S, but regeneration does not desorb filters. In Cu filters, S can easily form Cu and Zn sulphide, difficult to remove from filters. Both metallic filters capture F and S but the regeneration does not desorb them completely.

Zeolites captures F, Cu, Ni, S but regeneration does not fully desorb them. The gas

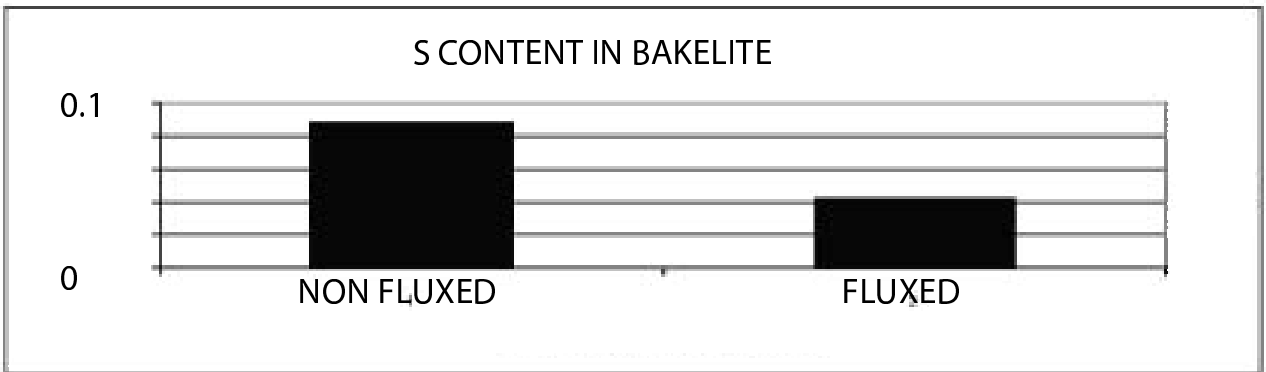

Figure 24: Bakelite concentration (S).



mixture (due to the presence of HF) tends to leach  $\text{SiO}_2$  and  $\text{Al}_2\text{O}_3$  i.e. the framework of zeolite. Chemical analyses show a depletion in Si, Al contents in zeolites. A buffering effect is observed, with pH changing from 4.5 to 7.0 before and after the zeolite purifier.

The regeneration procedure used was not optimized for each filter. The regeneration procedure used is probably the one recommended by the zeolite producer. Purifiers Cu and CuO-ZnO are declared as nonregenerable [17], and the regeneration protocol followed (see §3) is not able to desorb the purifiers, as it is not sufficient to achieve complete Cu reduction which requires temperatures in the  $350^\circ\text{C}$  range. Elements such as As and S react with the Cu and Zn constituents in the catalyst to form stable metal complexes which do not migrate or desorb off of the catalyst. It is important to characterize the filters (both metallic and zeolite) in order to understand their selective absorption and ion-exchange possibility, their lifetime (in function of the complex system at CL), and finally it is of paramount importance to set up a specific desorption procedure.

The trace elements found clearly in the gas mixture are Cd, Pb, Zn. A lot of F, Na and Ca is also found. Zn could be released by zeolites, but no depletion is shown by zeolite analyses. Na is abundantly present in gas before filtering (probably released by the bakelite of RPCs), it decreases after the zeolite (being exchanged with Ca in the zeolite), but it stays abundant after the metallic purifiers. The presence of Ca in the gas mixture has implications that should be studied in more detail. Finally, the operation duration of R3-12 filters critically depends on the abundance of As and S. Full understanding of the CL chemistry calls for more detailed and systematic gas analyses. The trace elements found are likely not to have effect on the operation of RPC detectors, namely the increase of dark currents observed. Later studies on the correlation between dark current increase and amount of contaminants will be subject of an upcoming paper.

In all fluxed bakelite samples we observe the presence of defects, in agreement with [8] [5]. The crystalline structure of defects has been observed for the first time, as well as the identification of such a crystalline structure as NaF. The presence of Na can be explained as accumulation process on defect of Na normally present in the bakelite bulk in form of NaOH.

Bakelites release elements (Ni, Cr, Cu, Zn) due to a leaching process by the gas mixture. These elements can be filtered, and they actually are filtered by the zeolite which keeps such elements and undergoes successful regeneration for them. The bakelite samples analyzed show a depletion in some trace elements ( Cu, Ni, As, Cr,Sb) after flux, with Cu and Ni possibly being adsorbed in zeolite.

Although this study explains some effects of the complex material science phenomenology in the RPC detector at the CL gas system, most of the basic questions on the chemistry of gas and purifiers remain obscure. A systematic investigation is in progress

at the CL prototype setup for chemical sampling of gas and purifiers, and correlation with currents behaviour in dedicated RPC detectors.

## 7 APPENDIX I

A brief description of the materials used for purifying the gas mixture at the CL system is given in this Appendix.

### 7.1 Molecular sieve 5Å Type by ZEOCHEM

Zeolite molecular sieves are crystalline, highly porous materials, which belong to the class of aluminosilicates. These crystals are characterized by a three-dimensional pore system, with pores of a precisely defined diameter. The corresponding crystallographic structure is formed by tetrahedrons of  $(\text{AlO}_4)$  and  $(\text{SiO}_4)$ . These tetrahedrons are the basic building blocks for various zeolite structures, such as zeolites A and X, the most common commercial adsorbents.

Due to the presence of alumina, zeolites exhibit a negatively charged framework, which is counter-balanced by positive cations resulting in a strong electrostatic field on the internal surface. These cations can be exchanged to fine-tune the pore size or the adsorption characteristics. For instance, the sodium form of zeolite type A has a pore opening of approximately 4Å, and it is called called a 4Å molecular sieve. If the sodium ion is exchanged with the larger potassium ion, the pore opening is reduced to approximately 3Å (3Å molecular sieve). On ion exchange with calcium, one calcium ion replaces two sodium ions. Thus, the pore opening increases to approximately 5Å (5Å molecular sieve). Ion exchange with other cations is sometimes used for particular separation purposes [25].

Zeolite A, like other zeolites, is synthesized in a gelling process. Sources of alumina (usually sodium aluminate) and silica (usually sodium silicate) are mixed in basic water solution to give a gel. The alkali agent can be NaOH or solutions of quaternary ammonium salts, amines, or other polar organics. The gel is then heated to 70-300 °C to crystallize the zeolite. The zeolite is normally synthesized in the  $\text{Na}^+$  form. This can account for Na presence in the 5Å zeolite LINDE Type A, and the non-complete ion exchange of  $\text{Na}^+$  by  $\text{Ca}^{++}$  can justify a 5% of NaO in CL molecular sieve. Chemical composition of standard LINDE Type A zeolite is [26–31]

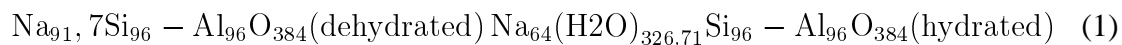

ZEOCHEM [16] Molecular Sieve type 5Å is an alkali alumino Silicate, and it is the calcium form of the Type A crystal structure. Typical chemical formula for ZEOCHEM

molecular sieve 5Å is

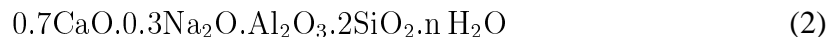

Type 5Å has an effective pore opening of 5Å. It is especially suitable for Pressure Swing Adsorption (PSA) applications where it may be used for the separation of normal- and iso-paraffins (C4 to C6 species), in PSA hydrogen purification and in oxygen concentrators. It is an excellent adsorbent to remove water, CO<sub>2</sub>, H<sub>2</sub>S from sour natural gas streams, while minimizing COS formation. Light mercaptans are also adsorbed. It is also used for the separation of normal- and iso paraffins, and production of high purity N<sub>2</sub>, O<sub>2</sub>, H<sub>2</sub> and inert gases from mixed gas streams. ZEOCHEM molecular sieve Type 5Å can be regenerated by either heating in the case of thermal swing processes; or by lowering the pressure in the case of PSA processes. To remove moisture from a 5Å molecular sieve, a temperature of 250-300°C is required. A properly regenerated molecular sieve can give moisture dew points below -100 °C, or mercaptan or CO<sub>2</sub> levels below 2 ppm[16].

## **7.2 Cu-Zn filter type R3-12 by BASF (25%), Cu filter type R3-11G from BASF (25%).**

BASF Catalyst R3-12[17] is designed for removal of arsine, phosphine, H<sub>2</sub>S and COS in the treatment of process and product streams. Catalyst R3-12 is widely used in the purification of polymer grade propylene, and in guard beds to protect noble metal catalysts from arsenic and sulphur. Arsenic and sulphur react with the Cu and Zn constituents in the catalyst to form stable metal complexes which do not migrate or desorb off of the catalyst, therefore making R3-12 not regenerable. The composition is nominally 40 wt.% CuO, 40 wt.% ZnO, and 20 wt.% Al<sub>2</sub>O<sub>3</sub>.

BASF Catalyst R3-11G[17] is designed for regenerative removal of O, CO, H and others from industrial gases and liquids, composition is CuO. Capacity and lifetime vary, depending on levels of arsine and sulphur, on the space velocity, and other factors.

## **7.3 Ni-AlO<sub>3</sub> filter type 6525 by LEUNA (50%)**

LEUNA Catalyst Ni-AlO<sub>3</sub> filter type 6525[18] is used for hydrogenation of benzene, phenols and cresols, reduction amination of alcohols, aldehydes and ketones into the corresponding amines, methanations. The catalyst consists of approximately 60 wt % Ni in alumina tablet form. The data sheet suggests the need to inquire the company for a suitable regeneration procedure. It is declared vulnerable to humidity, and the presence of very fine dusty particulates which calls for a particulate filter.

## 8 APPENDIX II

Materials studied in this paper were analyzed following the protocols standard of chemical analysis. Table 1 shows the analysis technique for each sample, a brief description of the techniques is also added for the reader informations.

Table 1: Synopsis of chemical analyses performed on filters, gas and bakelite.

SAMPLE	ANALYSES
MOL. SIEVE 5Å UNUSED	1,2
MOL. SIEVE 3Å UNUSED	1,2
Ni Al <sub>2</sub> O <sub>3</sub> UNUSED	1
Cu CuZn UNUSED	1
Cu PIPE UNUSED	1,3
BAKELITE A OILED UNUSED	1,3
BAKELITE B OILED UNUSED	1,3
BAKELITE C OILED GRAPHITE UNUSED	1
MOL. SIEVE 5Å USED	1,2
Ni Al <sub>2</sub> O <sub>3</sub> USED	1
Cu CuZn USED	1
BAKELITE A OILED GRAPHITE USED	1,3
BAKELITE B OILED GRAPHITE USED DEFECT	1,3
MOL. SIEVE 5Å REGENERATED	1,2
MOL. SIEVE 3Å REGENERATED	1,2
Ni Al <sub>2</sub> O <sub>3</sub> REGENERATED	1
Cu CuZn REGENERATED	1
WHITE SAMPLE NATURAL ZEOLYTE	1,2
GAS BEFORE AND AFTER FILTERS	4
ABBREVIATIONS	
1	X-Ray Fluorescence ICP-AES (Inductive Coupled Plasma- Atomic Emission Spectroscopy) NAA (Neutron Activation Analysis) ICP-MS (Inductive Coupled Plasma-Mass Spectrometry)
2	XRD (X-Ray Diffraction)
3	SEM-EDS (Scan. Electron Micr. - Energy Dispersive Spectrum)
4	HPLC (High Pressure Liquid Chromatography)

A brief description of analysis methods used in this study is given [32]

- XRF (X-Ray Fluorescence) is the emission of characteristic "secondary" (or fluorescent) X-rays from a material that has been excited by bombarding with high-energy X-rays or gamma rays.
- ICP-MS (Inductively coupled plasma mass spectrometry) is a type of mass spectrometry that is highly sensitive and capable of the determination of a range of metals and several non-metals at concentrations below one part in 10<sup>12</sup>. It is based on coupling together an inductively coupled plasma as a method of producing ions (ionization) with a mass spectrometer as a method of separating and detecting the ions. ICP-MS is also capable of monitoring isotopic speciation for the ions of choice.

- NAA (Neutron Activation Analysis) is a nuclear process used for determining certain concentrations of elements in a vast amount of materials. NAA allows discrete sampling of elements as it disregards the chemical form of a sample, and focuses solely on its nucleus. The method is based on neutron activation and therefore requires a source of neutrons; a range of different sources can be used.
- ICP-AES (Inductively Coupled Plasma-Mass Spectrometry), also referred to as inductively coupled plasma optical emission spectrometry (ICP-OES), is an analytical technique used for the detection of trace metals. It is a type of emission spectroscopy that uses the inductively coupled plasma to produce excited atoms and ions that emit electromagnetic radiation at wavelengths characteristic of a particular element. The intensity of this emission is indicative of the concentration of the element within the sample.
- XRD (X-Ray Diffraction) Powder diffraction is a technique used to characterise the crystallographic structure, crystallite size (grain size), and preferred orientation in polycrystalline or powdered solid samples. Powder diffraction is commonly used to identify unknown substances, by comparing diffraction data against a database maintained by the International Centre for Diffraction Data. It may also be used to characterize heterogeneous solid mixtures to determine relative abundance of crystalline compounds and, when coupled with lattice refinement techniques, such as Rietveld refinement, can provide structural information on unknown materials. Powder diffraction is also a common method for determining strains in crystalline materials. An effect of the finite crystallite sizes is seen as a broadening of the peaks in an X-ray diffraction as is explained by the Scherrer Equation.
- SEM-EDS (Scan. Electron Micr. - Energy Dispersive Spectrum) is an analytical technique used for the elemental analysis or chemical characterization of a sample. It is one of the variants of XRF. As a type of spectroscopy, it relies on the investigation of a sample through interactions between electromagnetic radiation and matter, analyzing x-rays emitted by the matter in response to being hit with charged particles. Its characterization capabilities are due in large part to the fundamental principle that each element has a unique atomic structure allowing x-rays that are characteristic of an element's atomic structure to be identified uniquely from each other.
- HPLC (High Pressure Liquid Chromatography) High-performance liquid chromatography (or High pressure liquid chromatography, HPLC) is a form of column chromatography used frequently in biochemistry and analytical chemistry to separate,

identify, and quantify compounds. HPLC utilizes a column that holds chromatographic packing material (stationary phase), a pump that moves the mobile phase(s) through the column, and a detector that shows the retention times of the molecules. Retention time varies depending on the interactions between the stationary phase, the molecules being analyzed, and the solvent(s) used. In this method, high pressure (rather than gravity forces) can propel mobile phase through the column packed with a stationary phase of much smaller particle sizes. This allows for a quicker and more precise analysis on columns of shorter length, when compared to plain column chromatography.

## 9 Acknowledgements

We thank F. Hahn (CERN) for illuminating discussions, and L. Daniello, B. Ponzio (Frascati), V. Darras (CERN) for technical help. This work was supported by the Italian Istituto Nazionale di Fisica Nucleare and Ministero della Università e della Ricerca.

## References

- [1] R. Santonico and R. Cardarelli, “Development Of Resistive Plate Counters,” Nucl. Instrum. Meth. **187** (1981) 377.
- [2] R. Adolphi *et al.* [CMS Collaboration], “The CMS experiment at the CERN LHC”, JINST **3** (2008) S08004.
- [3] J. Va’vra, “Physics and chemistry of aging: Early developments,” ICFA Instrum. Bull. **24**, 1 (2002) [Nucl. Instrum. Meth. A **515**, 1 (2003)].
- [4] J. Va’vra, “Summary of session 6: Aging effects in RPC detectors,” Nucl. Instrum. Meth. A **515**, 354 (2003).
- [5] M. Abbrescia *et al.*, “Gas analysis and monitoring systems for the RPC detector of CMS at LHC,” LNF-06-34-P, LNF-04-25-P, Jan 2007. 9pp. Presented by S. Bianco on behalf of the CMS RPC Collaboration at the 2006 IEEE Nuclear Science Symposium (NSS), Medical Imaging Conference (MIC) and 15th International Room Temperature Semiconductor Detector Workshop, San Diego, California, 29 Oct - 4 Nov 2006. arXiv:physics/0701014.
- [6] L. Benussi *et al.*, “The CMS RPC gas gain monitoring system: an overview and preliminary results,” Nucl. Instrum. Meth. A **602** (2009) 805 [arXiv:0812.1108 [physics.ins-det]].

- [7] L. Benussi *et al.*, JINST **4** (2009) P08006 [arXiv:0812.1710 [physics.ins-det]].
- [8] M. Abbrescia *et al.*, “HF Production In Cms-Resistive Plate Chambers,” Nucl. Phys. Proc. Suppl. **158** (2006) 30. NUPHZ,158,30;
- [9] M. Abbrescia *et al.*, “Study Of Long-Term Performance Of Cms Rpc Under Irradiation At The Cern Gif,” Nucl. Instrum. Meth. A **533**, 102 (2004).
- [10] S. Agosteo *et al.*, “A facility for the test of large area muon chambers at high rates,” Nucl. Instrum. Meth. A **452** (2000) 94.
- [11] M. Abbrescia *et al.*, “Proposal for a Systematic Study of the CERN Closed Loop Gas System Used by the RPC Muon Detectors in CMS”, Frascati preprint LNF-06/27(IR), available at <http://www.lnf.infn.it/sis/preprint/> .
- [12] G. Saviano *et al.*, “Materials studies for the RPC detector in CMS ”, presented at the RPC07 Conference, Mumbai (India), January 2008.
- [13] S. Bianco *et al.*, “An analysis of materials used in the RPC detector and in the closed loop gas system of CMS at LHC”, Frascati preprint LNF-08-33(IR), available at <http://www.lnf.infn.it/sis/preprint/> .
- [14] M. Bosteels *et al.*, “CMS Gas System Proposal”, CMS Note 1999/018.
- [15] L. Besset, F. Hahn, S. Haider, C. Zinoni, “Experimental Tests with a Standard Closed Loop Gas Circulation System”, CMS Note 2000/040.
- [16] Manufactured by ZEOCHEM AG, Seestrasse 108, 8708 Uetikon (Germany).
- [17] BASF Technical Bulletin.
- [18] LEUNA Data Sheet September 9, 2003, Catalyst KL6526-T.
- [19] CMS RPC bakelite sheets are produced by PANPLA, Pavia, Italy.
- [20] C.Pucci, MD Thesis, Sapienza Università di Roma (2006) (in Italian). Frascati preprint LNF-06/31(Thesis).
- [21] The linseed oil used for CMS RPC is produced by GALLO srl, 61030 Tavernelle di Serrungarina, Italy.
- [22] G. Aielli *et al.*, “Fluoride production in RPCs operated with F-compound gases”, 8th Workshop on Resistive Plate Chambers and Related Detectors, Seoul, Korea, 10-12 Oct 2005. Published in Nucl.Phys.Proc.Suppl. **158** 143-148, 2006.

- [23] R. de Asmundis, "Application Of Gas Chromatographic Analysis To Rpc Detectors In The Atlas Experiment At Cern-Lhc," JINST **2**, T06001 (2007).
- [24] R. de Asmundis, "Online gas analysis and diagnosis for RPC detectors in the ATLAS experiment," Nucl. Instrum. Meth. A **572**, 40 (2007).
- [25] GRACE Davison Molecular Sieves data sheet.
- [26] LINDE Technical Bulletin.
- [27] Subhash Bhatia, "Zeolite Catalysis: Principles and Applications", CRC Press, Inc., Boca Raton.
- [28] B. Fherrerros, "The X-Ray Diffraction Zeolite Database on the web".
- [29] W.M. Meier *et al.*, "The Atlas of Zeolite Structure Types on the web", Florida, 1990.
- [30] J.D. Sherman, "Synthetic zeolites and other microporous oxide molecular sieves", Proc. Natl. Acad. Sci. USA **96** (1999) 3471-3478.
- [31] Zeolite atlas on [//www.iza-structure.org/databases/](http://www.iza-structure.org/databases/).
- [32] [www.wikipedia.org](http://www.wikipedia.org)