

LNF-07/ 21 (IR)
October 9, 2007

**PROPOSAL FOR A SET UP OF AN RF POWER HALL FOR X-BAND
ACCELERATING STRUCTURES TESTING AT LNF**

D. Alesini¹, R. Boni¹, M. Calvetti¹, V. Chimenti², A. Clozza¹, A. Gallo¹, L. Pellegrino¹,
R. Ricci¹, C. Sanelli¹, B. Spataro¹, F. Tazzioli¹, C. Vaccarezza¹

¹*INFN, Lab Nazionali di Frascati, via E.Fermi 40 - 00044 Frascati(RM), Italy*

²*CNAO Foundation, via Caminadella 16 - 20123 Milano, Italy*

Abstract

In this paper we present a study to provide the LNF, under the Accelerator Division responsibility, of an RF power hall to accommodate a 50 MW X-Band klystron together with its High Voltage modulator to be used as a test stand for characterizing high frequency RF accelerating structures. The proposal is to locate the Test Hall in a portion of the LNF building #7 where a shielded bunker already exists and has been used to test and pre-conditioning the DAFNE RF cavities before their installation in the accelerator halls.

1 INTRODUCTION

There is a worldwide growing interest around RF accelerating structures working in the X-band to be used in various different accelerator contexts. The frequencies considered for these structures are 11.4 GHz or 12.0 GHz, i.e. the 4th harmonic of the standard S-band frequencies used in linear accelerators. Linacs for FEL radiation production based on S-band technology make use of X-band harmonic cavities for longitudinal phase space linearization, while proposals of compact light sources fully based on the X-band technology are being considered. Moreover, recently the CERN has chosen to base its multi-TeV linear collider project (CLIC) on X-band accelerating structures. After a brief period of quiescence following the decision of basing the International Linear Collider (ILC) on Superconducting RF technology, all these projects are now pushing toward a new R&D effort on the X-band accelerating technology. Being involved in FEL radiation production projects (SPARC, SPARX) as well as in the CLIC test facility projects (CTF), the Accelerator Division of the INFN Frascati Labs would like to enhance its R&D activities on the X-band technology by setting up a facility dedicated to high-power testing of accelerating structures of various kinds. Such a facility would allow complementing and completing the cavity design and fabrication R&D activities already established in the Labs in the last 5 years mainly in the form of INFN 5th National Scientific Board projects (SAFTA2, SALAF). The high power X-band test hall would also complement the activity of the brazing facility that has been recently (2006) installed and put in operation at the Accelerator Division of the INFN LNF.

In this paper we present the preliminary design of such a facility and a first implementation cost estimate.

2 X-BAND CAVITY DESIGN AND FABRICATION R&D AT LNF

Resources and man-power have been dedicated in the near past at LNF to study and develop X-band accelerating structures. The R&D activity has been carried out in the framework of the SAFTA2 (Studi Avanzati di Fisica e Tecnologia degli Acceleratori, 2002-2004) and SALAF (Sezioni Acceleratrici lineari ad Alta Frequenza, 2005-2007) projects financed by the INFN 5th National Scientific Board. It aimed at realizing standing wave (SW) accelerating sections gaining experience in design, manufacturing, brazing and testing of such RF structures. This activity has also made use of the recently installed brazing facility consisting in a dedicated oven purchased and put in operation. A picture of the oven is shown in Fig. 1, while some structures brazed at the LNF facility are described in [1].

The main characteristics of the oven are:

- Temperature in the 600 ÷ 1200 °C range;
- 300 mm (diameter) × 800 mm (height) thermal chamber volume;
- Temperature uniformity < ± 5 °C @ 1200 °C;
- Operational vacuum in the 10⁻⁶ mbar;
- PLC control allowing automatic operation to implement custom thermal cycles.



Fig. 1: Picture of the LNF brazing facility.

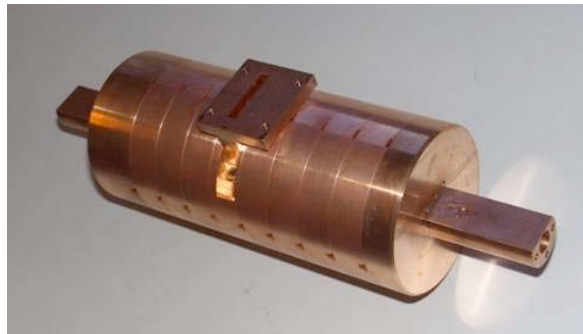

Fig. 2 : π - mode accelerating structure.



Fig. 3 : $\pi/2$ – mode accelerating structure.

In particular the following activities have been achieved:

- design, realization, brazing and electromagnetic characterization by bead pull measurements of a copper SW 9 cells structure operating on the π and $\pi/2$ modes (Figs.2 and 3) [2,3];
- tuning studies by deformation technique of X-band cavities [4];
- thermal analysis of X-band copper devices (Fig. 3) [5];
- realizations of accelerating structures using molybdenum and copper- molybdenum and electroforming procedures (Figs. 4 and 5) [1,6].

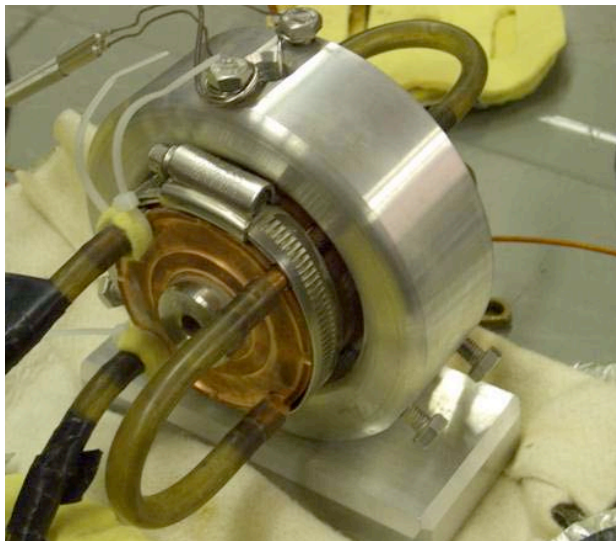

Fig. 3: copper prototype for thermal studies.

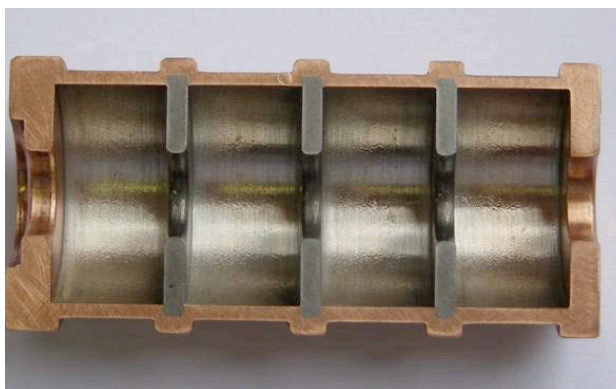

Fig. 4: Sample of Mo-Cu structure



Fig. 5: Mo-Cu electroformed structures.

One of the first applications of the LNF X-band R&D activity will be the construction of a 11.4 GHz SW cavity for the longitudinal phase space linearization of the SPARC photo-injector beam [7].

3 THE X-BAND HIGH RF POWER TEST FACILITY: TECHNICAL ASPECTS

The research program on X-band accelerating section concerns both Traveling Wave (TW) and Standing Wave (SW) structures, and our test facility is intended to make experimental tests on both of them. The TW sections are generally easier to tune, can accommodate a large number of cells all powered through the same coupler, and do not require any matching or protection in the connection network to the klystron. On the other side, SW cavities are more compact and can reach higher gradients, but being highly reflective in the transient phase can not be connected directly to a klystron [8]. In S-band systems ferrite circulators can be interposed between klystrons and cavities, to protect the tube and convey the reflected power to dummy loads. However, ferrite circulators are not available in the X-band, and much less efficient matching networks have to be interposed to protect the klystrons.

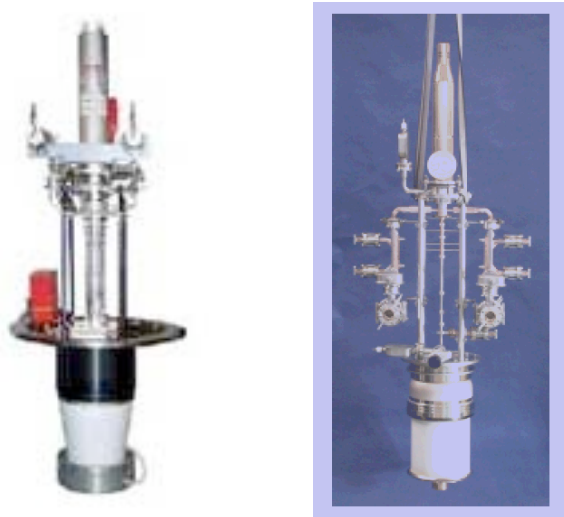

Fig. 6: Toshiba and SLAC X-band klystrons

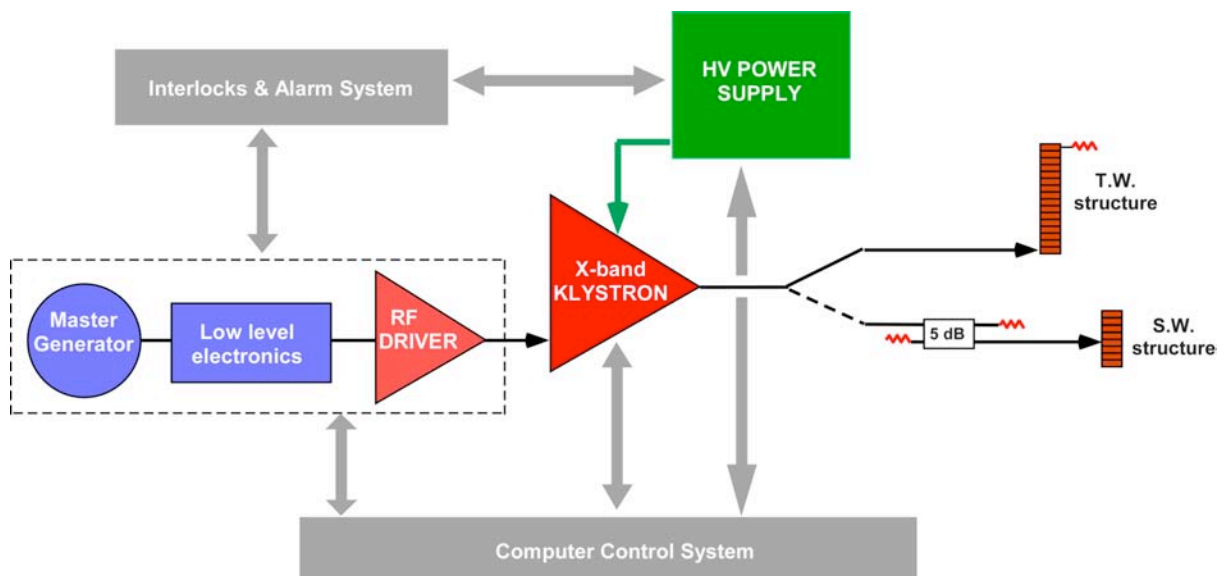

Fig. 7: Schematic layout of the test facility.

The design of the test facility is based on a commercially available X-band klystron, because the development of a custom tube would require a relevant extra-cost and a longer delivery time. This circumstance restricts the choice to an 11.4 GHz, 50 MW peak power tube, which is available on the market being produced by two different suppliers (Toshiba and SLAC). Pictures of existing X-band klystrons are reported in Fig. 6. A basic block diagram of the RF power facility for testing the X-band accelerating structures is presented in Fig. 7.

The low-level RF signal is generated by a frequency synthesizer and then is manipulated by a dedicated RF control section to generate the low-level RF pulse of proper amplitude and duration. In particular, the pulse duration is a parameter playing a very important role in trying to reach the highest gradients, requiring therefore a precise and flexible control. The control electronics hardware has to be also interfaced to the interlock electronics to rapidly switch-off the drive signal in case of failures.

The klystron drive signal needs to be pre-amplified to a level of ≈ 100 W peak. Depending on the klystron gain this task could be accomplished by a solid state driver or, more likely, by a pulsed TWT tube. The klystron output is connected to the structure under test by means of a waveguide network based on the standard EIA WR90 rectangular guide operating in the TE₁₀ mode. At the operating frequencies this guide shows a non-negligible attenuation of ≈ 0.1 dB/m. However, being the network only few meters long the waveguide attenuation is tolerable.

The klystron output is connected through a waveguide network to either a TW section or a SW cavity. The power tube can be set at any level up to its maximum while testing TW section. On the contrary, in order to prevent mismatch damage, a connection through the coupling port of a 5 dB directional coupler for SW cavity testing is foreseen. In this last configuration a ≈ 10 dB isolation between tube and resonator is obtained, at cost of reducing the available RF power at the cavity input to $\approx 1/3$ of the klystron peak power. Only in case of very low-power SW cavity tests (< 5 MW peak) a direct connection to the klystron is allowed. The klystron characteristics and some figures describing the capability of the test facility in terms of maximum obtainable gradients are reported in Table I. The klystron has to be equipped with a HV power supplier delivering 3.5 μ sec HV pulses of 470 kV and 260 A, with a maximum repetition rate of 50 Hz. Sophisticated power suppliers of this kind are produced by specialized companies and available on the market.

Table I: Klystron characteristics and maximum obtainable gradients.

Klystron peak power	50 MW max
RF pulse duration	1 μ s max
Video pulse duration	3.5 μ s
Pulse rep. rate	50 Hz max, 25 Hz typ
TW section RF power	45 MW max
SW section RF power	15 MW max
Average accelerating field in TW sections	55 MV/m max
Average accelerating field in SW sections	200 MV/m (10 MW into 1 cell)
Peak surface field in SW sections	350 MV/m

Besides the low-level RF control, the ancillary systems required for the test facility operation are:

- a) Vacuum for the structure under test and for the waveguide network;
- b) Cooling for the structure under test ($0.1\text{ }^{\circ}\text{C}$ temperature stability) and for the klystron
- c) Computer control and diagnostics
- d) Supply from the AC mains
- e) Safety and radioprotection

4 THE X-BAND HIGH RF POWER TEST FACILITY: LOGISTIC ASPECTS

The high RF power facility for testing the X-band accelerating structures may be located in LNF building #7 denominated “Technologies Lab”, which is already provided with a concrete shielding bunker that has been used for testing and conditioning of the DAFNE RF cavities.

The plant of the building is shown in Fig. 8. The whole facility will occupy an area of $\approx 12 \times 12\text{ m}^2$, including the $\approx 4 \times 5\text{ m}^2$ bunker. The klystron and the accelerating structures under test, together with the connecting waveguide network, have to be placed inside the bunker for radiation safety, while the klystron high voltage power supply, the low-level RF electronics, the control and interlock system hardware can be placed outside the bunker.

The building is already equipped with AC mains of sufficient power, while a cooling system that had been used for the DAFNE RF cavity conditioning is already installed. The cooling system could be re-used for the X-band test hall with some maintenance and modifications to cope with the tight specifications of temperature stabilization of the RF structures. Pictures of the building #7 bunker as it appears now are shown in Fig. 9.

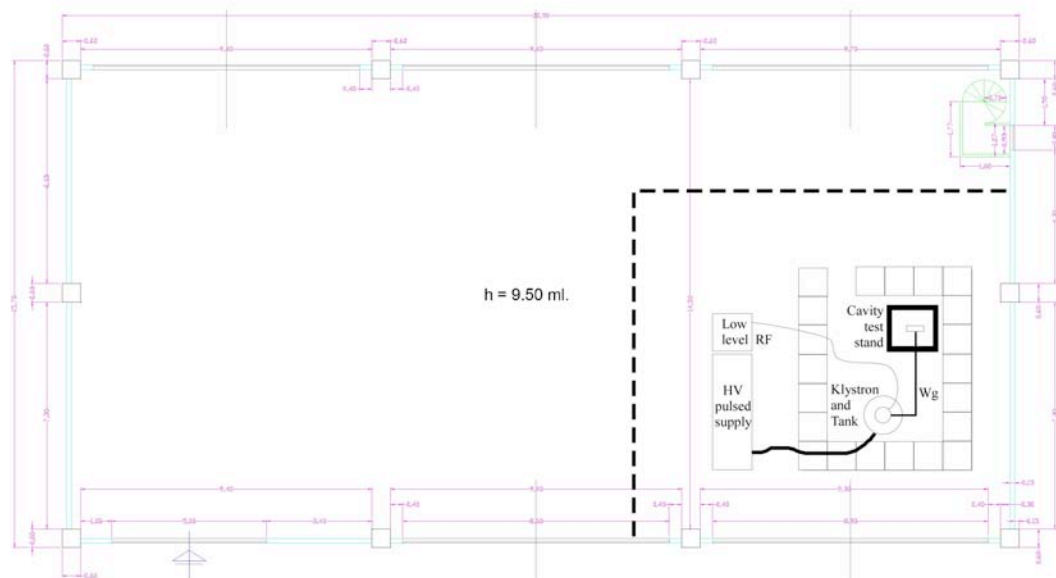

Fig. 8: Plant of the X-band Test Hall housed in LNF building #7.

Since the RF characteristics of the new test hall are very much different respect to that specified for the DAFNE cavity conditioning, the radioprotection system of the whole area needs to be reconsidered to obtain the required authorizations to operate the facility.



Fig. 9: Building #7 internal views.

5 COST AND IMPLEMENTATION TIME ESTIMATE

A preliminary analytic cost estimate for the implementation of the test hall is reported in Table II. The final cost is ≈ 1.5 M€ VAT included, with $\approx 80\%$ due to the klystron and HV power supply.

An implementation plan is reported in Fig. 10, showing that a period of ≈ 24 months starting from the approval of the project is necessary to purchase the hardware and complete the installation.

Table II: preliminary analytic cost estimate.

SYSTEM	Costs (k€)
Klystron and tank	540
HV pulsed power supply	600
RF Driver 500 W	60
Master oscillator and low-level RF controls	70
Waveguides and ancillaries	70
Instrumentation	60
Vacuum	35
Computer control and diagnostics	25
Cooling system (maintenance and modifications)	20
AC Main connection	10
Area cleaning and renewing	10
TOTAL (VAT included)	1500

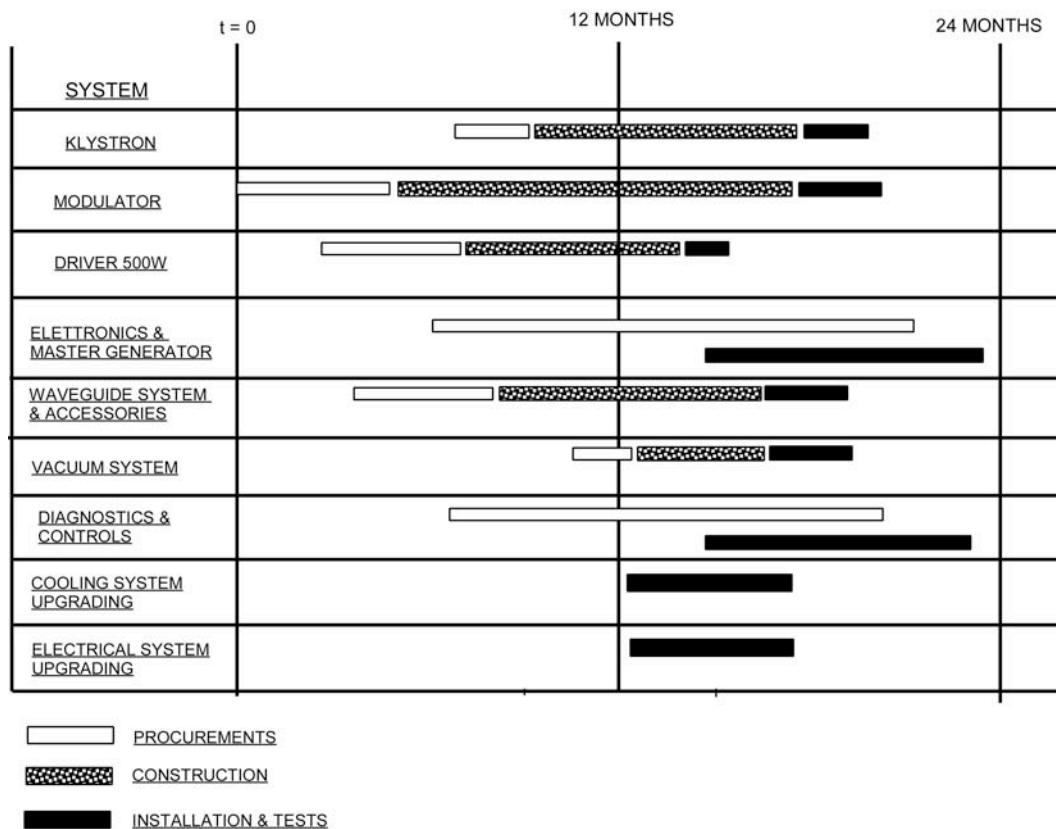

Fig. 10: Chart of the implementation plan.

REFERENCES

- [1] S. Bini, et al., SPARC tech. note, RF-07/004
- [2] B. Spataro, et al., NIM-A 554-(2005)
- [3] B. Spataro, et al., SPARC tech. note, RF-03/002, and LNF tech. note, LNF-03-013(R).
- [4] Maurizio Ronzoni, tesi di laurea triennale Univ. "La Sapienza", a.a. 2005/2006.
- [5] S. Bini et al., NIM A 578 (2007) 55-64
- [6] S. Bini, et al., SPARC tech. note, RF-07/003
- [7] Technical Design Report for the SPARC Advanced Photo-Injector, Technical Report, LNF-INFN, ROMA, 2003.
- [8] SLAC PUB 10370 February 2004