

ISTITUTO NAZIONALE DI FISICA NUCLEARE

Sezione di Roma 2

INFN/TC-97/15

29 Maggio 1997

M. Casolino, M. De Pascale, A. Morselli¹, L. Narici, P. Picozza, V. Prigiobbe, R. Sparvoli, O. Adriani, P. Spillantini, G. Castellini, S. Bartalucci, C. Catena, D. Conti, M. Ricci, E. Righi, B. Spataro, G. Trenta, M. Durante, G. Gialanella, G. Grossi, M. Pugliese, G. Barbiellini, M. Boezio, A. Vacchi, N. Zampa, W.G. Sannita, L. Lopez, M. Peresson, S. Conforto, I. Bodis-Wollner, C. Basar-Eroglu, A.P. Burlina, P. Renzi, C. Tanzarella, G. Alberici, L. Casoli, S. Cerdonio, A. Lenti, A. Galper, Yu. Ozerov, A. Popov, V. Zemskov, V. Zverev, A. Alexandrov, S. Avdeev, V. Shabelnikov:

**Experiment for Light Flash Observation in Space
(ELFO)**

Experiment for Light Flash Observation in Space
(ELFO)

- M. Casolino, M. De Pascale, A. Morselli¹, L. Narici, P. Picozza, V. Prigiobbe, R. Sparvoli
Dept. of Physics, Univ. of Rome "Tor Vergata" and INFN Sez. Rome2 , Italy.
O. Adriani, P. Spillantini
Dept. of Physics of Univ. and Sez. INFN of Florence, Italy.
G. Castellini
IROE of CNR, Florence, Italy
S. Bartalucci, C. Catena, D. Conti, M. Ricci, E. Righi, B. Spataro, G. Trenta
L.N.F. - INFN, Frascati (Rome), Italy.
M. Durante, G. Gialanella, G. Grossi, M. Pugliese
Dept. of Physics, Univ. "Federico II", Naples, Italy.
G. Barbiellini, M. Boezio, A. Vacchi, N. Zampa
Dept. of Physics of Univ. and Sez. INFN of Trieste and INFN, Italy.
W.G. Sannita
Dept. of Motor Sciences/Neurophysiopathology - Univ. of Genova, Genova, Italy and
Dept. of Psychiatry, SUNY, Stony Brook, NY, USA
L. Lopez
Consultant neurophysiologist - ITAB - University "G. D'Annunzio", Chieti, Italy
M. Peresson
Div. of Neurology, Hospital Fatebenefratelli - S. Pietro, Roma, Italy
S. Conforto
Dept. INFOCOM, Univ. Rome "La Sapienza" and Dept. Mechanics and Automatics, Univ.
Roma3, Roma, Italy
I. Bodis-Wollner
Dept. of Neurology, SUNY, HSCB, Brooklin, NY, USA
C. Basar-Eroglu
Institute of Psychology and Cognitive Research, University of Bremen, Bremen,
Germany
A.P. Burlina
Div. of Neurology, Hospital of Castelfranco Veneto, Italy.
P. Renzi
Dept. of Psychology, Univ. of Rome "La Sapienza", Rome, Italy.
C. Tanzarella
Dept. of Biology, Univ. of Rome3, Rome, Italy.

G. Alberici, L. Casoli, S. Cerdonio, A. Lenti
Laben S.p.a., Milan, Italy.
A. Galper, Yu. Ozerov, A. Popov, V. Zemskov, V. Zverev
Moscow Engineering and Physics Institute, Moscow, Russia.
A. Alexandrov, S. Avdeev, V. Shabelnikov
Russian Space Corporation Energia, Kaliningrad, Moscow region, Russia.

¹ Corresponding author: morselli@roma2.infn.it

Abstract

We present the scientific case for a thorough investigation of light flashes (LFs) observed by astronauts since early lunar missions.

A complete assessment of the phenomenon is achieved through a sophisticated helmet-like silicon detector put on the head of the astronauts. This device will be able to identify cosmic ray nuclei and measure their energy and trajectory, in order to correlate each light flash with the single particle likely producing this effect.

In addition, a study of precise time-correlation between cosmic ray impinging on the head of the cosmonaut and functions in the Central Nervous System (CNS) is addressed via investigation of the concurrent spontaneous bioelectrical cortical activity in the cortex (EEG) and of retinal and cortical responses at luminance and contrast stimuli (ERG,VEP).

This joint knowledge will help in identifying the interaction mechanism behind light flashes, and in building better models of visual sensory processes.

The silicon detector will also give information for a more accurate biological dosimetry by the knowledge of the relative fluences of the different particles: a contribution for a deeper understanding of the physiological modifications during long manned missions.

The proposed apparatus is supposed to work on-board of the Russian MIR Space Station or, later, on board of the International Space Station ALPHA.

CONTENTS

Introduction

1. **The radiation field in space**
2. **Single-event visual perceptions in space and cosmic particles transit: a scientific case and an electrophysiological approach**
 - 2.1 Background
 - 2.2 Physiological motivation
 - 2.3 Purpose of the study and methods
 - 2.4 Expected relevance of information to be obtained
3. **Spaceflight environment and radiation risks**
4. **The basic features of the experiment**
 - 4.1 The silicon detector
 - 4.2 The EEG system
 - 4.3 The MEG option
5. **Flight measurements and analysis**
 - 5.1 Methods and strategy
 - 5.2 Data processing
 - 5.3 Light Flash Electrophysiological Correlates (LiFEC)
6. **Ground measurements**
7. **Biological Dosimetry**
 - 7.1 Cytogenetic methods
 - 7.2 Individual radiosensitivity
 - 7.3 Research design and methods
8. **Concluding remarks**

References

Introduction

The phenomenon of light flashes observed by astronauts since the early lunar missions (Apollo-11 and following) is certainly the most impressive example of radiation-induced effects on living objects in space and almost the only one detected on humans, to our knowledge. Many attempts have been done in the past to fully assess the origin and nature of this phenomenon but a systematic, thorough investigation has never been performed.

In particular, we should mention that in the recent past we have already built a prototype silicon detector (Si-eye 1) for an experiment, which was performed on the Russian Space Station MIR in the period October 1995 - March 1996, and we are presently working on a more refined version (Si-eye 2), which will be launched within the next few months. However, we expect that these experiments will only partially clarify the problem, due to their small geometrical acceptance: they address, in fact, only the questions related to the particle-retina interactions. It is conceivable that interactions may occur at different level in the visual system, from the optic nerve to the visual areas, in the occipital regions of the cortex. For these reasons the use of a helmet shaped particle detector, covering a quite large solid angle and able to identify incoming particles over a large part of the cortex, is mandatory. Beside the ability of studying cosmic rays entering the head from many sites and directions, such detector will substantially improve detection statistics.

In the following we present in detail the scientific motivations for a new experiment, which will make use of a sophisticated silicon apparatus.

This device will be integrated with other systems, like whole head computerized EEG and VEP, needed to investigate the effects of the particles on the brain and, in particular, on the visual system. These methods allow for a high time resolution discrimination of events in the bioelectrical functions in the cortex and often permit to localize the cortical site where such events occur.

Furthermore, the increased number of manned space missions stresses the importance of estimating the biological risks encountered by astronauts. As they are exposed to space radiation it is necessary to measure the doses they receive. The proposed silicon detector is able to identify charged particles and measure their energy.

The fundamental goals of our project can be summarized as follows:

- a) a definite assessment of the mechanism which gives rise to the light flashes;*
- b) a complete and accurate monitoring at the single particle level of the whole radiation impinging on the human skull;*
- c) a possible correlation between space radiation and functional responses of the bioelectrical brain activity.*
- d) an additional information for more accurate dosimetry.*

This experiment, named ELFO (Experiment for Light Flash Observation in Space), is conceived to be performed on the MIR Space Station or on the ALPHA Space Station.

1. The radiation field in space

A body in space is exposed to a low flux of particles of a wide spectrum in mass and energy, which impinges from different directions in a more or less isotropical way. This fact explains the uniqueness of the cosmic radiation and the difficulty of simulating its complex spectrum by using particle accelerators on ground. These are single, mono-energetic sources of particles that are produced in a narrow unidirectional beam. In addition, out of the wide spectral energy range of cosmic ray particles, especially high Z energetic (HZE) nuclei that are of special interest for biological research, only a few narrow energy ranges are available at accelerators.

If we look at the ionizing radiation, we can distinguish 4 main categories:

- galactic cosmic radiation (GCR);
- very high-energy, extra-galactic cosmic rays;
- solar energetic particle radiation (solar flares);
- particle radiation trapped in the Van Allen belts.

The arriving flux of GCR has been investigated using balloons and satellite experiments and is mainly composed of protons and heavier nuclei (98%), stripped of all their orbital electrons, and of electrons and positrons (2%). The nuclear component consists of $\approx 87\%$ hydrogen, $\approx 12\%$ helium, and $\approx 1\%$ for all heavier nuclei in the general energy range where they have the highest intensity, namely, 100 MeV - 1 GeV per nucleon. Nevertheless, the spectra extend up the energies in excess of 10^{10} GeV, although we believe that above 10^8 GeV these nuclei are extra galactic in origin.

The energy range and the presence of high-Z nuclei among GCR make this radiation extremely interesting for radio biological studies concerning manned mission outside the geomagnetic shielding.

The light, extra-galactic high energy particles, like electrons and positrons, have been deemed for a long time to be among the responsables for the light flashes observed by astronauts through Cherenkov effect in the vitreous.

Solar flares are strong sources of nuclear cosmic rays of energy similar to GCR, though satellite experiments could determine the composition and spectrum of solar energetic particles only up to about 100

MeV/n and a few hundred MeV for protons. Solar flares with generation of high energy nuclei are rare, but, as in 1999, when the solar activity reaches its maximum, about ten of such events per year will occur. For different flares, substantial variations in fluences and shape of the energy spectra have been observed.

Most observations of the light flash phenomenon were done at altitudes of a few hundred kilometers, where orbits cross the Earth radiation belts, which are the result of the interaction of solar and galactic particles with the Earth's magnetic field. In particular, for a relevant fraction of the orbit period, the space station MIR crosses the South Atlantic Anomaly (SAA), where the radiation belt reaches down to an altitude of 200 Km and the highest rates are mainly protons.

More recently, electrons and positrons with energies up to several hundred MeV have been observed. The possibility of having high energy nuclei, like helium, trapped in the radiation belt is not ruled out. For sake of completeness, we should mention the anomalous component of cosmic rays (ACR), which consists of partially (or singly) ionized interstellar atoms accelerated at the termination shock and penetrating inside the heliosphere. Their energy can vary from 10 MeV up to several hundred MeV what is sufficient to reach the vicinity of the Earth and to be observed by satellites at high altitudes or outside the magnetosphere.

2. Single-event visual perceptions in space and cosmic particles transit: a scientific case and an electrophysiological approach.

2.1 Background

The first reports of unexpected visual sensations during spaceflights came from Apollo-11 in 1969. These phenomena, known as light flashes or light flares (LF), were subsequently also reported by astronauts on Apollo-12 and 13 [1]. They appeared as faint spots of flashes of light after some dark adaptation and occurred spontaneously and randomly. This prompted the organization of dedicated observation periods during the remaining Apollo flights. Totally 12 astronauts spent close to 20 hours in observations. It was found that on average after some 15-20 minutes of dark adaptation about one LF every 3 minutes was seen. Three basic types of flashes were reported: "spots" or "star-like flashes", "streaks" and "clouds".

A further kind of LF was observed very recently by a Russian astronaut on board of the MIR Space Station (Si-Eye 1 experiment [2]), that is characterized by the presence of some concentric circles [3].

At the same time, several studies were done with accelerator beams exposing the human eye and brain to well-defined particle fluxes. It was found that neutrons, when having an energy of more than about 5 MeV, could cause LF sensations [4, 5, 6, 7], while a beam of π^+ with momentum 1.5 GeV/c did not create any effect. Studies using cosmic muon [8] and a 6 GeV/c muon beam [9] also reported a LF effect.

Several possible explanations were put forward. They included Cherenkov light in the vitreous [10], or a direct excitation of the retina by ionization [10,11], possibly an indirect effect from protons knocked out by neutrons [4] or from α particles from reactions with C, O or N atoms [7]. It was also suggested that scintillation in the eye lens [12] could cause the observed LFs. Experiments with Helium and Nitrogen beams, however, seemed to pinpoint the effect to the retina [13].

Still many questions remain to be answered, such as which particles in space cause the LFs and how frequent are they in Earth orbits. Further, it was not completely ruled out that the Cherenkov effect, or something

else, may play a role during space flights. Therefore, experiments were conducted on Skylab in 1974 [14] and on Apollo in the Apollo-Soyuz project in 1975 [15]. Correlation with particle fluxes were done, but not conclusive results were obtained. Indeed, some results seem even contradictory, such as a big increase in the LF rate on the South Atlantic Anomaly (SAA) that was seen on Skylab, but not on Apollo.

To make a systematic study over several space missions and with many subjects of LF phenomena, we designed and sent an active particle detector (Si-eye 1) to the MIR space station. Our main goal was to nail down which particle caused which kind of LF phenomena in space. The particle telescope is constituted of three 60x60 mm² wide silicon planes, each composed of two detectors, 0.380 mm thick and divided in 16 strips, glued back to back with the strips in x and y directions, respectively. The layers are placed 5 cm apart. The detector was put in front of an eye of the astronaut and all particles were detected and stored with the respective time during each measurement session. The trajectory of a charged particle can be reconstructed with an accuracy of ± 2 degrees and localised in the eye field within 3 mm. Besides, in connection with the vision of a light flash, the astronaut registered the event and the time pushing a button on the keyboard of the computer. This apparatus has been taking data on the MIR for some months and the very first results show the correlation of at least one LF event with a determined, rather low-energy proton [2]. However, the LF brightness was reported to be weaker in the SAA than at higher latitudes. Since the proton flux in the SAA is known to increase by several orders of magnitudes in comparison with the equator, it is quite possible that the main responsible for LF in orbit are not protons, but heavy ions.

Of course, this hypothesis requires confirmation, so that we are presently testing an improved detector (Si-Eye 2) that will be sent to the MIR this year. The basic sensitive element of Si-Eye 2, similar to Si-Eye 1, and the more performant front-end and read-out systems are derived from the NINA telescope, devoted to the study in space of the anomalous components of the cosmic rays, that will be launched in orbit in 1997 on board of the Resource 04 n.1 satellite. The new electronics widens the dynamical range allowing to study high Z nuclei.

It must be pointed out that no complete agreement exists between Apollo, Skylab and MIR results, particularly when looking at the number of LFs. This is due to basic differences not only in the experimental methods but also in experimental conditions, like orbits, altitude, shielding, changes

of the solar activity, human reactivity and so on. In particular, the present detectors do not allow to identify correlation between LF and the passage of a given particle with a good statistical level.

Therefore, an exhaustive study requires an apparatus that achieves a sufficient counting rate and also allows to detect those particles entering the head from different sides and not only from the eyes.

2.2 Physiological motivation

In spite of the observed correlation between trajectory and transferred energy of particles flux at retinal level and the reported perceptual phenomena, the neurophysiological relevance and mechanisms of generation of these events have not been investigated and it is unclear whether the phenomenon is the result of the activation of physiological mechanisms of vision. Comparable transient visual alterations are in fact experienced by patients, e.g. during the first stages of retina detachment, at the beginning of migraine episodes, or in concomitance of simple partial epileptic seizures originating in primary visual cortex. Phosphenes of unknown origin are often reported by healthy subjects in the absence of any history or evidence of ocular, neurological or systemic disease. All these visual symptoms are, to a relevant extent, expression of enhanced/distorted function of those mechanisms which mediate visual information processing in physiological conditions. In particular, these perceptual events suggest a role of the basic mechanisms dedicated to the detection of simple physical characteristics of visual stimuli, such as luminance change, motion, contrast, etc. It is also known that X-rays at low doses can alter the light sensitivity threshold by acting at retinal level [16].

It appears a practicable hypothesis that the particle flux may, in peculiar conditions, trigger (directly or indirectly) physiological mechanisms of the visual system or, in alternative, alter its functional status (e.g. sensitivity) so to change the effect of external events (e.g. particles). Retina and visual cortex are both putative sites of action of triggering particles.

2.3 Purpose of the study and methods

The project is aimed to identify physiological functions/mechanisms of the visual system that are dedicated to simple feature detection and:

- a) may respond peculiarly (i.e. with greater sensitivity) to the impact of particles flux on retinal and/or cortical structures;
- b) may be modified in peculiar conditions (such as those that crewmembers adapt to while in orbit) resulting in a functional setting that favours response(s) to external events (e.g. particles flux) that would otherwise be ineffective in physiological condition at sea level. Aspects of adaptation to light and darkness and of the wakefulness/sleep cycle also involving the melatonin-dopamine balance cycle over 24 h will also be investigated.

The approach will be both physical and electrophysiological and the study will be carried out both on laboratories at sea level and on spacecraft in orbit. The project will need the availability of:

- a) proper devices to detect and quantify the presence, trajectory and transferred energy of particles flux at the eye and brain level. A detector similar to Si-Eye, but covering a large part of the head, seems to have the suitable characteristics;
- b) devices for non-invasive detection of the cortical bioelectrical currents dynamics with temporal resolution sufficient to discriminate and study the different components of the evoked responses as well as the dynamics of the spontaneous brain activity. The capability of retrieving information about the location of the active cortical sites is also important.

Two non-invasive measurement strategies share the ability to resolve activities within the millisecond range: ElectroEncephaloGraphy (EEG) [17], a measurement of the dynamics of the electric potential on the scalp generated by the underlying bioelectrical currents and MagnetoEncephaloGraphy (MEG) [18], by which the associated magnetic field over the scalp is measured, using low temperature superconducting magnetometers (SQUIDS). The two techniques are strongly linked, both

investigating the dynamics of the bioelectrical currents in the cortex, and offer informations which are mostly overlapping and sometimes complementary. Even though MEG features a better source localization capability, EEG is of easier implementation in space environment, features the same time resolution and offers good insights about dynamics and source locations of cortical activity. This makes EEG a good choice for a neurophysiological investigation of the mechanisms linked to LF perception, preliminary to the space implementation of a more powerful and sophisticated technique such as MEG. The electrophysiological spontaneous brain activity (electroencephalogram, EEG) will be investigated together with the potentials originating at retinal or cortical levels in response to visual stimuli, as light flashes, (cortical visual evoked potentials, VEP; electroretinogram, ERG; retinal oscillatory potentials, OPs), and, in general, to the passage of the particle through the brain.

The spontaneous EEG will also be continuously monitored to check for changing in vigilance within the wakefulness state or shifts from vigilance to patterns of sedation or to light sleep.

We should mention here that EEG studies in space have been occasional. Furthermore most of them were designed primarily to evaluate sleep characteristics under weightless conditions [19,20], following complaints for insomnia and fatigue, presented by the crews of three of the earlier Skylab missions. Postflight analyses of these recorded EEG data revealed no abnormalities throughout the flight and postflight periods.

2.4 - Expected relevance of information obtained during the study

The information obtained from this study will then be of relevance in regard to the effects of the particles flux on mechanisms/functions of the human visual system as well as for the definition of the visual system functional conditions in spacecraft setting. This information may be used proficiently to improve the operative conditions of human living and performing in spacecraft; potentially, it can be extrapolated to ameliorate the interactions between humans and computer-controlled operating devices and to implement the available knowledge about the human visual system in physiological and pathological conditions.

3 Spaceflight environment and radiation risks

In section 2.3 we stressed the possible importance in LF perception of the peculiar conditions of space environment. Looking for a deeper understanding of the physiological modifications during a prolonged manned mission, we also propose the use of the same silicon detector for advanced fluence dosimetry.

The combined influence of different space flight factors is, in fact, one of the key problems in space medicine; it is of particular interest to understand the mechanisms underlying the interaction of radiation and microgravity. Along the radiobiological chain of events, every step is affected by internal and external modifiers, therefore influencing the final radiation response.

The conventional risk assessment approach is based on the concept of dose equivalent (absorbed dose \times quality factor Q), where Q is taken as high as 20 for all high LET (Linear Energy Transfer) radiations [21].

Furthermore, the concept of dose equivalent assumes uniform distribution of energy through the tissue of interest, and doesn't distinguish among different particles having the same LET (it is an average value). It is, however, definitely clear that the risk factors are related more to the fluence spectrum of each particle and a fluence-based risk assessment must be introduced. Several experimental results support this statement, like the tumorigenesis in the mouse Harderian gland.

The concept of fluence-based risk assessment has been found to be radiobiologically sound, but the data necessary for applying it to humans in space is not available yet. Therefore, it needs:

- a development of an accurate dosimetry for conducting radiobiological studies, monitoring astronaut exposures and developing and testing models of the space radiation environment;
- a quantification of the various long-term biological effects as a function of dose equivalent and of the fluence of the different kinds of particles.

As far as it concerns the first point, a series of measurements at various positions on the different orbits can be performed with the particle detector used for the LFs study. This is able to identify charged particles and measure their energy, and, therefore, will give a good evaluation of the relative fluence of the different particles at fixed LET.

These information could give a significant improvement to the potentiality of the biological dosimetry, that will be described in detail in chapter 7.

4. The basic features of the experiment

We describe in the following the basic features of the experiment we propose in order to obtain the scientific goals described in the introduction.

The apparatus basically consists of two devices: *i*) a silicon detector optimized for low and medium energy nuclei and suitable to provide a good statistics and all particle information (kind of particles, energy, timing, trajectories); *ii*) a computerized EEG system to measure the concurrent changes in the cortical bioelectrical activity. Both will be arranged as a helmet-like device, shown in figure 1, that astronauts can wear easily and comfortably during data acquisition: an accurate analysis of all possible phenomena which are deemed to be produced by cosmic ray nuclei requires a coverage of the solid angle as large as possible.

To fix the main parameters of the silicon detector, we focalize our attention on the possible LF responsible mechanisms. Assuming the hypothesis that they are due to primary ionization in the retina by heavy ions, we first consider typical abundant nuclei in the GCR component, like ^{12}C , and ^{16}O . In our calculation the thickness of the sensitive part of the retina is fixed to $50\ \mu\text{m}$ and the traversed human body is considered to be equivalent to $3\ \text{g}/\text{cm}^2$ of H_2O .

From relevant measurements made on accelerators [15], we deduce that a typical LET threshold value for LF generation is between 10 and 20 $\text{KeV}/\mu\text{m}$, that corresponds to an energy deposition in the retina above 1 MeV. As a consequence, the useful energy interval of the particles impinging on a detector consisting of 3 Silicon planes, each made of a double $380\ \mu\text{m}$ thick chip as in Si-Eye experiments, ranges from ≈ 150 up to $\approx 400\ \text{MeV}/n$ for the Oxygen, while for the Carbon it is quite narrower. This region corresponds to the maximum flux of Oxygen GCR, as averaged over a polar orbit.

We have studied the silicon detector separation capabilities using both simulated and experimental data (Si-Eye 1). As a result, we have noted that an efficient separation can be obtained by plotting the difference of the energy deposited in the third and first silicon layers ($E_3 - E_1$) versus the energy deposited in the whole detector (E_{tot}).

In figures 2 and 3 are shown the particle separation capabilities for several nuclei of interest, for impinging particles with low and high energy respectively. The incident energy range is $50\ \text{MeV}/n - 1\ \text{GeV}/n$, so to

permit investigations of other cortical regions. It should be noted that even in the region with $(E_3-E_1) < 0.2$ MeV (corresponding to particles with high kinetic energy) it is possible to discriminate the nuclei (fig. 3), using E_{tot} as the only parameter.

At present, new performant algorithms are under test with Si-Eye 2 accelerator data, in order to obtain a better discrimination among the different nuclei. Further studies on the use of thicker detectors are in progress.

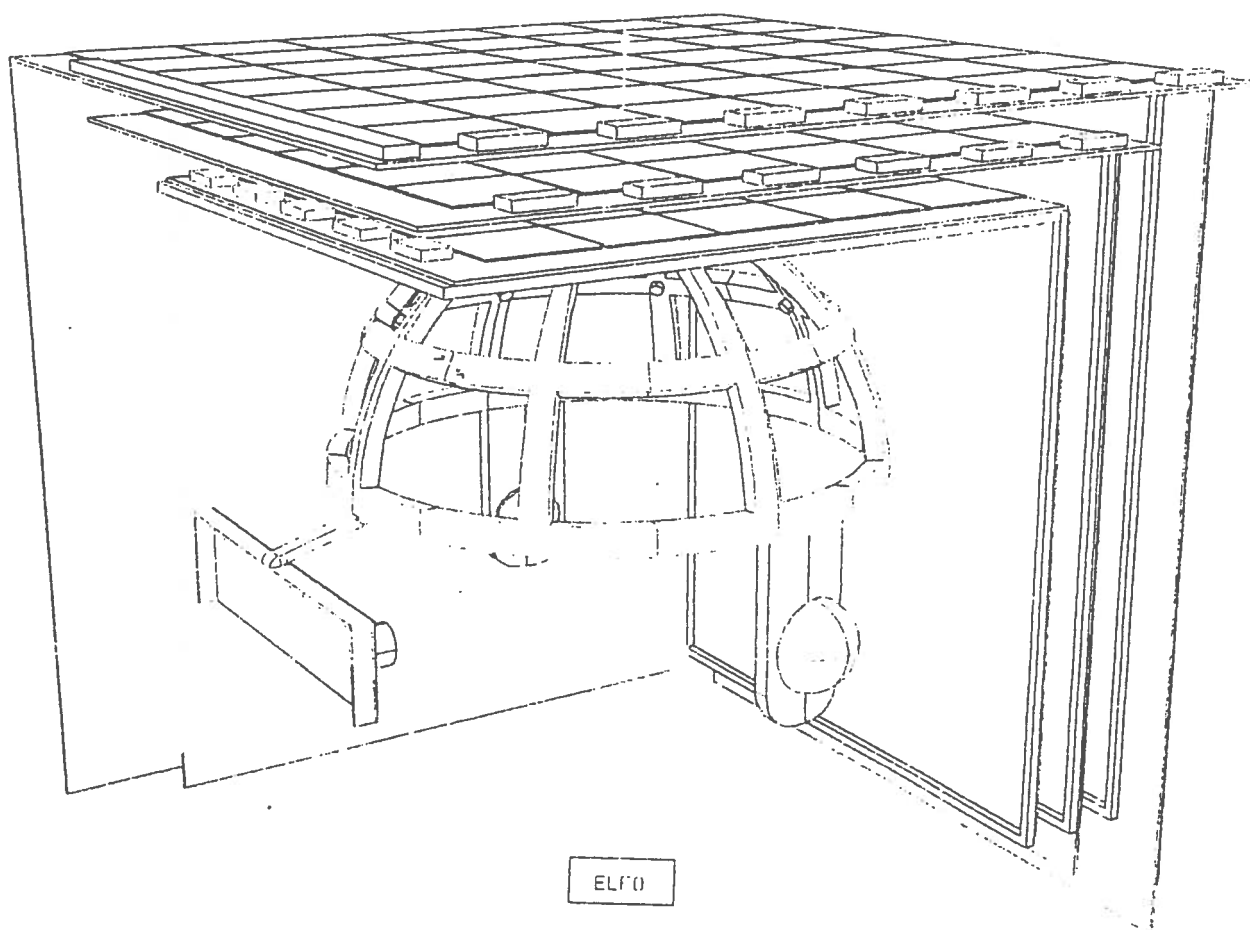

Fig. 1.1 General drawing of the detector

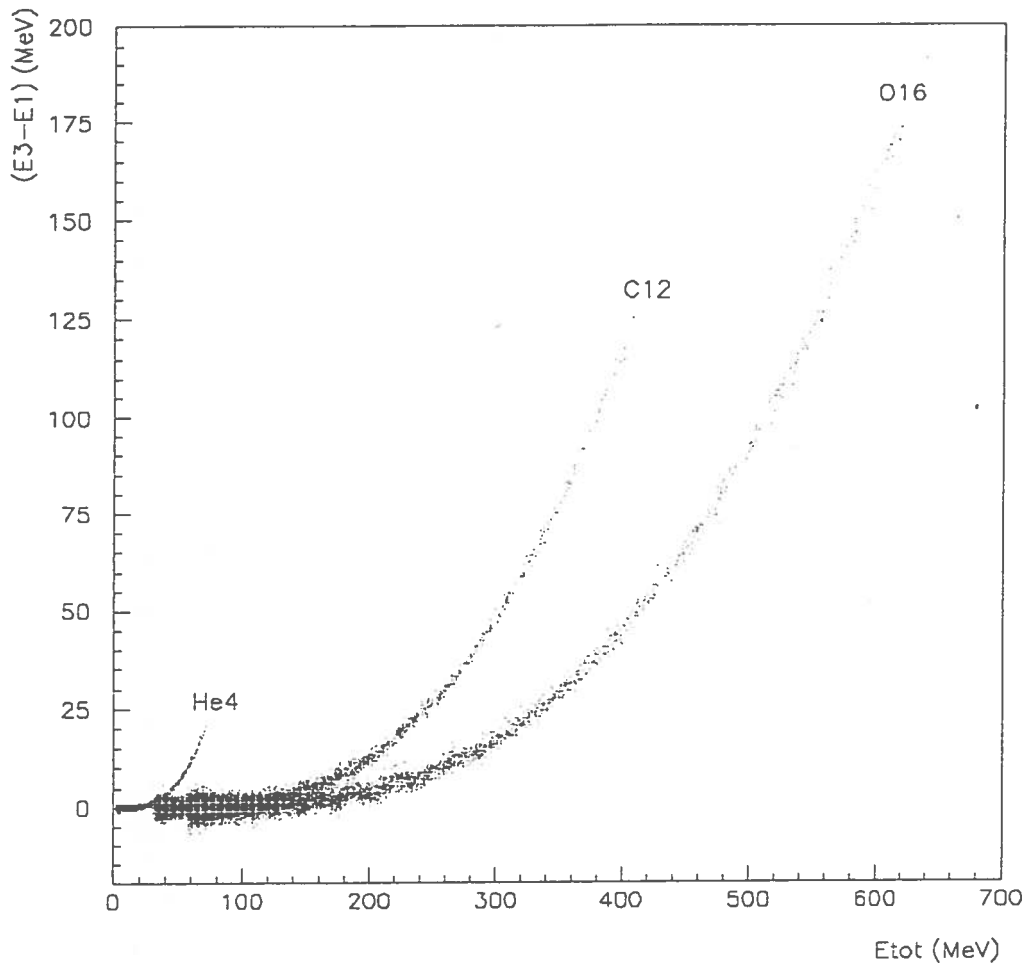

Fig. 2 Discrimination of nuclei with low incident energy;
 E_{tot} is the total energy released by the particles in the whole detector; E_3-E_1 is the released energy difference between the third and the first plane.

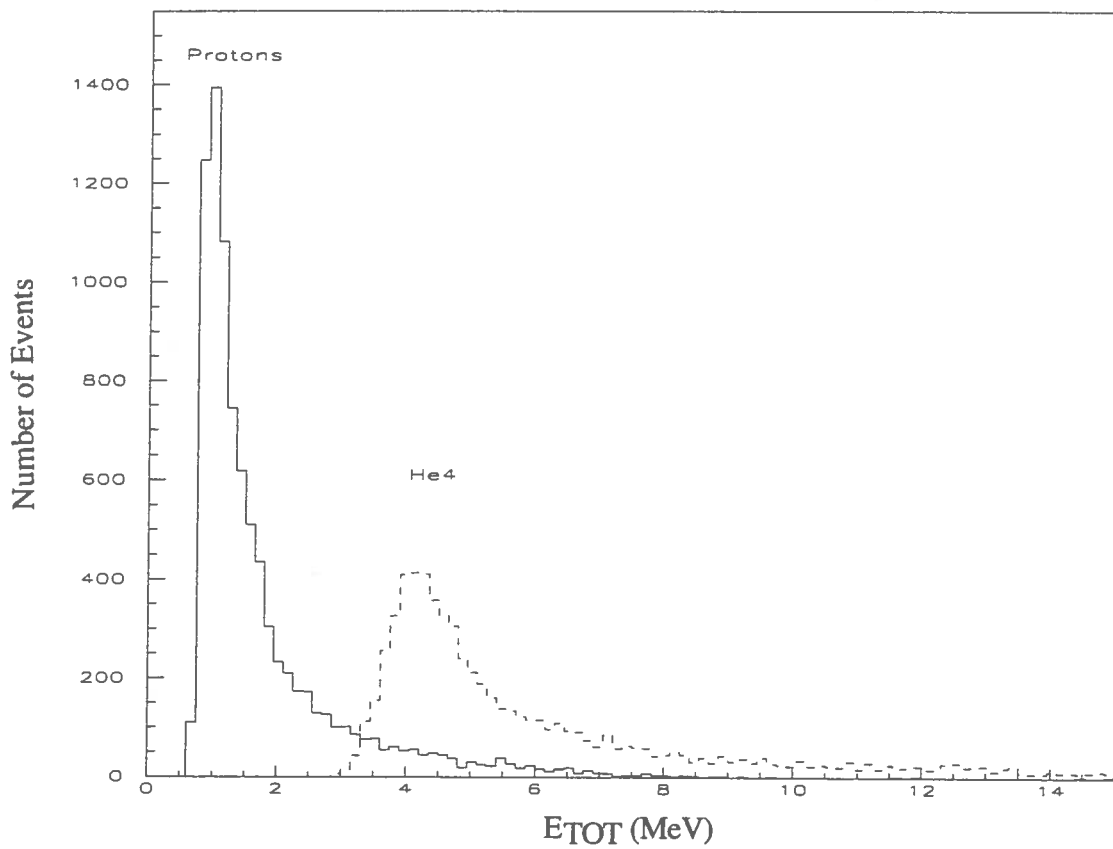
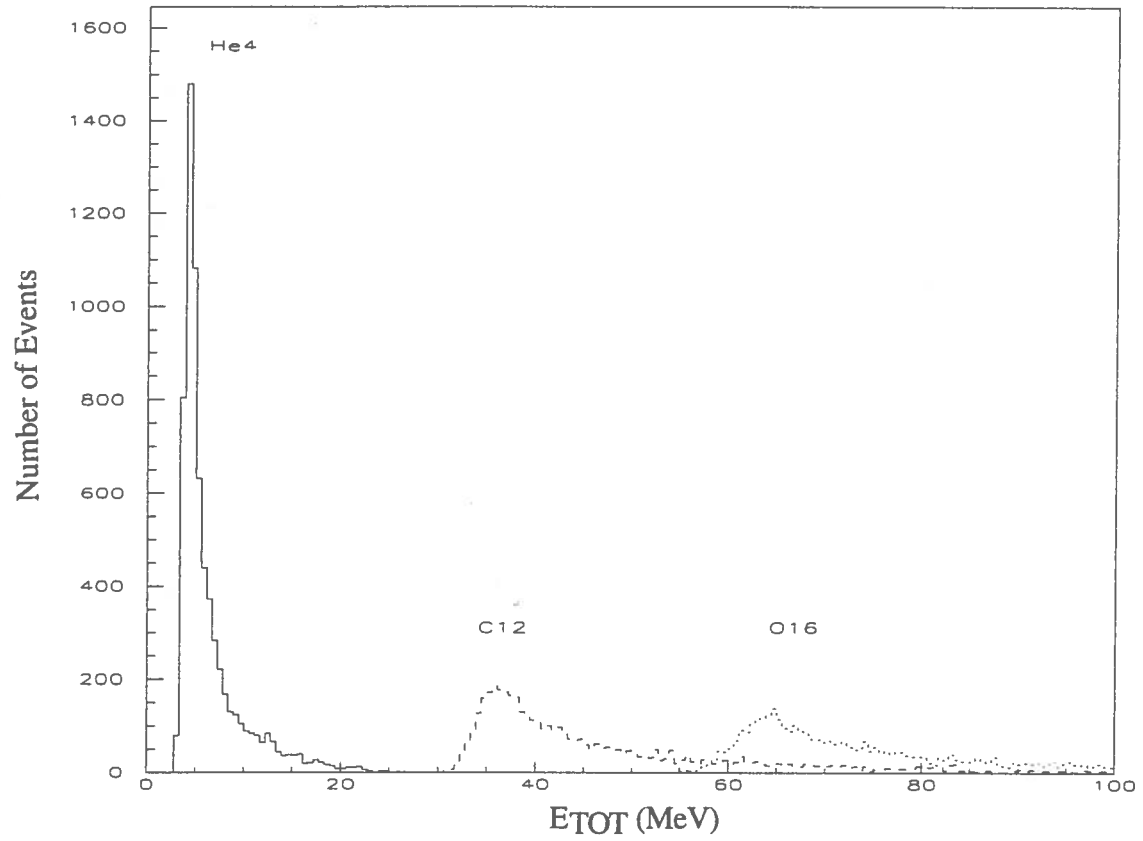

Fig. 3 Discrimination of nuclei with high incident energy ($E_3 - E_1 < 0.2$ MeV).

4.1 The silicon detector

The main task of the silicon detector is the identification of particles traversing the human head and the measurement of their energy and trajectory.

The basic technology to meet these requirements, as well as the typical power, weight and safety restrictions in space experiments, is the silicon strip sensors, already used in the Si-Eye 1, Si-Eye 2 and NINA telescopes.

The sensitive element is a silicon chip, 0.380 mm thick, with ion-implanted resistive strips on one side. The area is 60x60 mm², divided in 16 strips, with 3.6 mm pitch. A plane is composed by two such chips, glued back to back with perpendicular strips, to measure x and y coordinates of the crossing particle.

The whole detector (fig.1a) consists of 3 sets of 3 stacked sensitive planes divided in ladders. Each ladder (fig.1b) is composed of a definite number of silicon double sensors, whose strips are directly connected in order to create the independent detection element (in x or y direction).

The planes of the helmet, in the baseline design, are nine; three stacked layers in the three Cartesian directions having the inside helmet as target. The distance between the inner and the outer planes is 61 mm. Each plane is constituted of:

- Seven ladders of seven detectors for the planes of the external layer, six ladders of six detectors each for the intermediate layer and five ladders of five detectors for the internal layer.
- The Front End (F.E.) electronics placed at the end of the related ladder.

A dedicate space will be foreseen over one of the external planes for the Read Out electronics.

A general scheme of a detector plane and read out chain is shown in Fig. 4.

- Front End electronics

As far as F.E. is concerned, the experience gained working on NINA telescope may be exploited with some adjustments related to the different requirements of this experiment and to the configuration of the helmet detector (i.e. detector capacitance, dynamic, channels number etc..)

The choice of a NINA-like electronics will be the first step. We envisage to realize a prototype plane for testing the performance of the detector. The advantage of such a prototype is the possibility to deeply study the detector with a low-cost, not customized technology (Surface Mounting Device, SMD) and to optimize it with relation to the experiment demands.

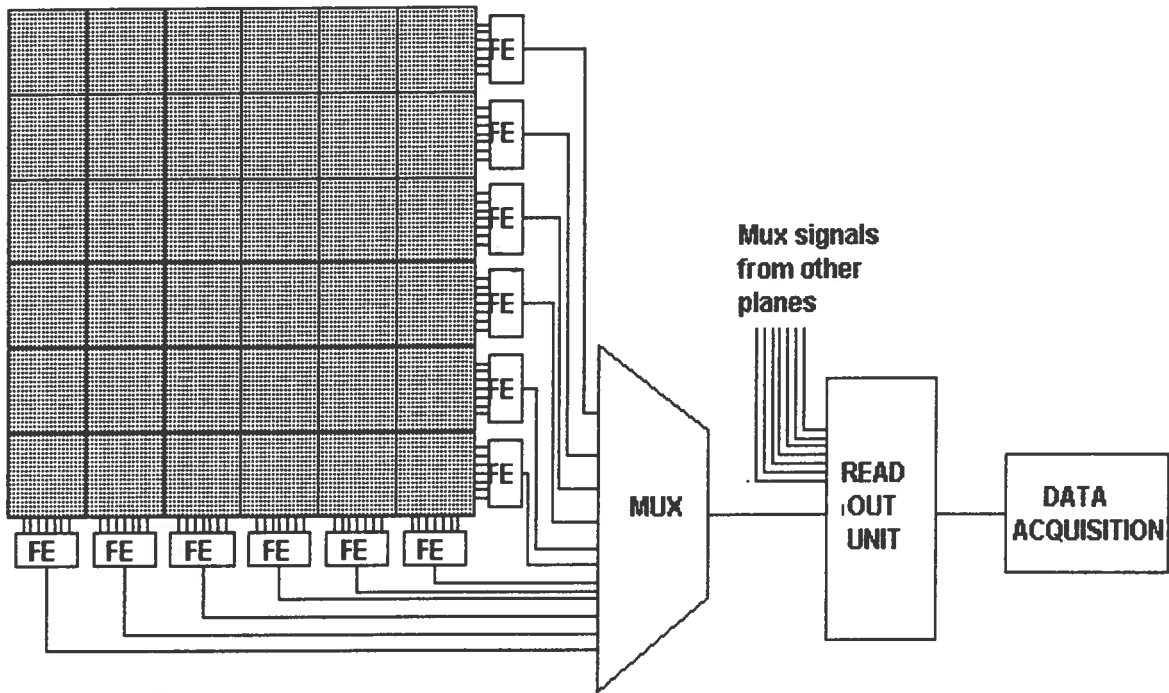

Fig. 4 General scheme of a detector plane and read out chain.

The second phase foresees a VLSI solution for F.E. electronics. With this improvement the detector as a whole will gain in compactness, which is fundamental for the realization of the whole helmet.

In figure 5 a NINA-like F.E. electronics scheme is shown for a single ladder. Output signals from each strip are sent to a charge preamplifier and then further processed in the shaping amplifier to improve signal to noise ratio and to obtain the amplitude required for the successive step of analysis.

One of the output signal from the shaper is sent to a coincidence unit to activate the trigger. To minimize the baseline drift due to the counting rate a DCR (DC level restoration) is inserted at the output of the shaper. DCR is followed by a Sample and Hold (S/H) that is activated when the trigger circuitry recognizes a good event. S/H works in a differential mode

in order to allow pedestal compensation. The hold capacitor and its serial resistors have two functions: in the hold phase the capacitors store the analog signal while in the sample phase the RC is used as a second integration of the shaper. Each processed signal goes to a 16x1 Multiplexer (MUX) which addresses the energy signal and gives only one output for each ladder. A second level 2n x 1 MUX provides a single signal from each plane. Last level 9x1 MUX is located in the common R.O. unit.

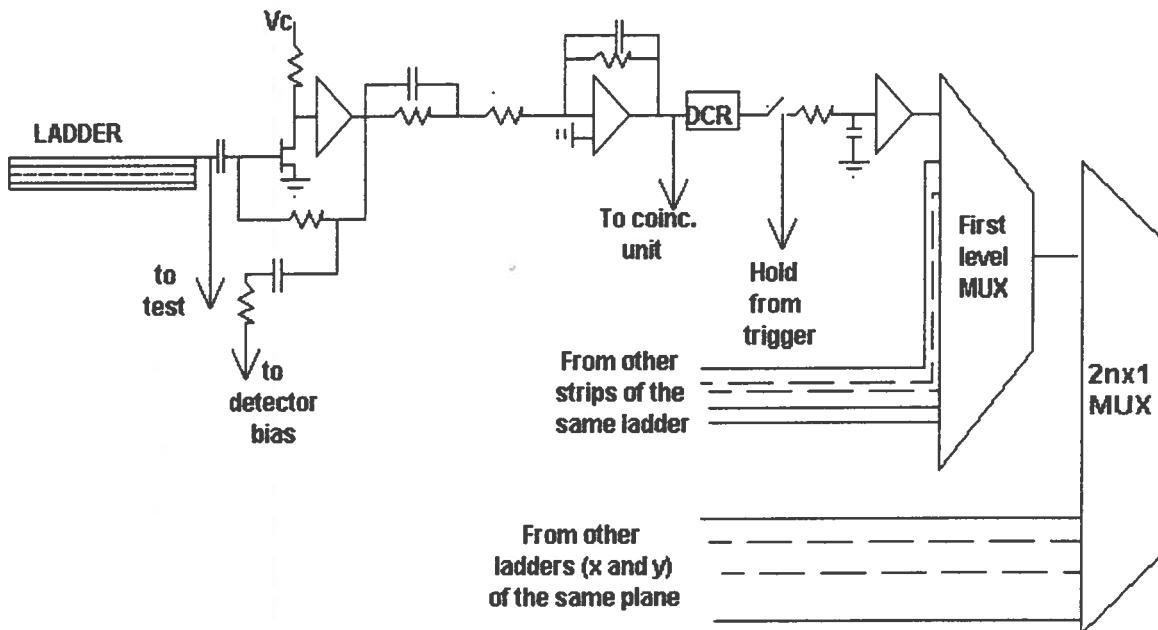

Fig. 5. Front End electronics for one channel of a single ladder.

The dynamic range of F.E. is 2500 mips, the same of NINA and Si-Eye 2. As far as energy threshold is concerned, it will be possible to have a changeable low level threshold to be varied with continuity directly by the operator starting from 2.5 mips. Moreover it might be convenient to look for a window threshold in energy in order to optimize data acquisition in different sessions.

- Read Out

The 9x1 MUX located on the Read Out unit sends its output to an ADC with 12 bit resolution. The R.O. sequence stops after about 1728 conversions executing the total reading in about 10 msec. A FIFO memory with 1 event depth is used to store data from ADC.

The sequencer shown in figure 6 is the logic circuit that generates signals to execute the R. O. sequence. Trigger logic gives hold signal to S/H

in the F.E. The block indicated with "test" in the figure is used for test sequence. Calibration, pedestal and noise tests are implemented.

- DAQ

Triggered events are read through an Interface by a Data acquisition system (DAQ) driven by a Microprocessor and stored in a FIFO memory.

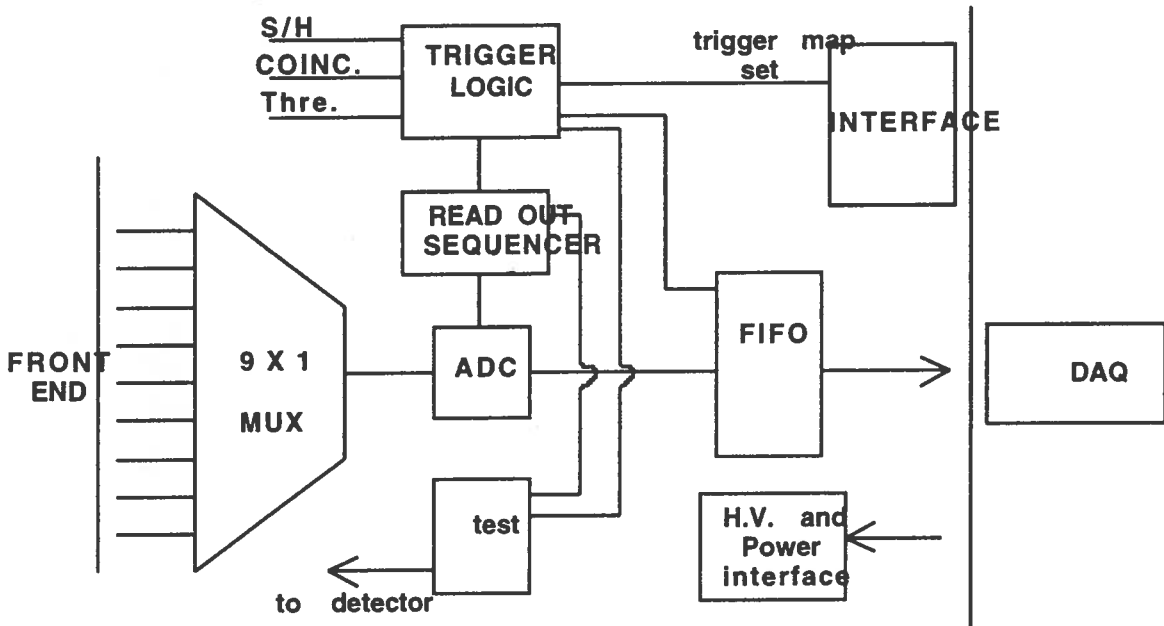

Fig. 6 Scheme of Read Out unit.

With the detector configuration described above, the total number of channels is 1728. Considering that the ADC conversion for each channel takes $4 \mu\text{s}$, the total reading is executed in less than 10 ms, corresponding to an acquisition rate greater than 100 Hz. This upper limit to acquisition rate is enough to cover high rate region of some orbits [2]. However the real acquisition rate is determined by trigger figure (for example by energy thresholds) and by the type of orbit. Different window thresholds in energy to be optimized in successive acquisitions may be considered; the optimization or even the set of different threshold acquisitions might be defined after analysis of data sent to earth via telemetry. Considering that a session lasts 90 minutes, that ADC conversion of each event takes 12 bit, the mean multiplicity per event is of the order of 10 channels and assuming a rate of about 100 Hz, the memory needed to store data for one

session is of the order of 10 MBytes. Thus, it is not a problem to store data in removable disks also in view of some acquisitions for dosimetry studies.

- Software

The software for data handling and test equipment will be implemented with the functions of zero skipping, gain normalization, data formatting, 2nd level trigger, data compression, manual setting and data storage.

4.2 The EEG system

Non invasive measurements of the electrophysiological signals will be performed via an array of electrodes, covering the entire scalp or proper portions of the projections to scalp of the stimulated cortex, positioned in accordance with international guidelines, under the silicon head helmet. Additional four electrodes will be used to monitor retinal potentials.

Each electrode will be connected to a multiplexer through a filter and a low noise preamplifier. The signal will be recorded onto a storage media for off-line analysis.

A computer controlled visual stimulator will deliver proper stimuli.

At sampling frequency of 1 KHz a 90 minutes experiment would require 5.4 MBytes of data for channel.

4.3 The MEG option

The measurement of the magnetic fields (of the order of 10^{-14} T) require a recently developed technology. The increased complexity in the measurement apparatus with respect with EEG, however, permits to reach a more detailed knowledge about cortical activities. The characteristics of the magnetic field in approximately spherical boundaries, in fact, mostly insensitive from intervening tissues, makes MEG a better technique for retrieving information about the localisation of the sources of the measured activities. It is a more "focused" method, mostly sensitive to the activities in the cortical region under the sensor. The neuromagnetic functional source localisation, together with the anatomical imaging

provided by MRI, permit what is known as "Magnetic Source Imaging", and represent the state of the art for cortical functional studies.

The electric potentials on the scalp, viceversa, are affected by the conductivities in the intervening tissues and by volume currents, and this makes more compicate the task of extracting source location, as well as the discrimination of concurrent activities, not easily manageable.

The most demanding MEG instrumental problems, especially when considering it for measurements in a space environment, comes from the need of cryogenics and noise shielding. Both have been proficiently solved in ground laboratories (large array of superconducting sensors, >100, covering the whole scalp are now in use around the world, both for research and clinic). Superconductive facilities are already planned for future manned space missions; furthermore, newly developed High-Tc SQUIDS have been succesfully used in ground laboratories for neurological measurements, producing a drastic relaxation of the cryogenic refrigeration requirements; electronic cancellation and proper sensor geometries may be used for noise reduction. It is therefore conceivable that an effort can be put for the realisation of a Space Neuromagnetic Helmet to be used by the astronauts. A further advantage of this device is its easiness of use: no electrodes must be mounted to perform a measurement.

Recent studies also suggest that interactions of the neuromagnetic sensors with cosmic particles would not constitute a problem.

5. Flight measurements and analysis

A measurement session as a rule will last about 90 minutes, which is equivalent to about one orbit. The orbit will be normally chosen such that it passes through the SAA. The astronaut wears the helmet and sits with his hands on two push-button transducers. Fifteen minutes of dark adaptation for the eyes are required, such that the subjects could confidently observe LFs.

5.1 - Methods and strategy

During the session, the measurement will be performed with the following procedure:

- a) The values of the released energy and the x,y coordinates of the particles crossing the silicon detector are continuously detected and stored for each of the six layers.
- b) Visual stimuli are delivered following the defined stimulation procedure, to measure the vigilance and attention levels of the astronaut as well as the other electrophysiological parameters of interest.
- c) The astronaut pushes the left or right transducer when he sees a light flash (due to particles or led) with the left or right eye, respectively. These informations and the relative time are stored.
- d) The electrophysiological signals that originate at retinal and cortical level (EEG, VEP, ERG, OPs) are continuously recorded during the dedicated observation sessions.

5.2 Data processing

The first step in the data processing consists in the reconstruction of particle tracks through the detector. Then, the amount of the energy lost by the charged particle in the silicon plates, together with the total energy lost in all plates, allows us to characterize energy and charge of each particle. It is, therefore, feasible to reconstruct the trajectory of the particle and estimate, by using a Bethe-Bloch technique, the energy left in

the different points of the brain. The recorded time connects the event with the position in the orbit.

It is possible at this point to look for potential correlations between the flashes observed by the astronaut and the particles crossing in a narrow time interval before the mark given by the pushing of the button.

In parallel, the occurrence of transient variations in the electrophysiological signal organization, in concomitance with the events noted by astronauts, will be identified and correlated to the particle flux. The relative effects of particles on the retina and visual cortex will be evaluated.

5.3 Light Flash Electrophysiological Correlates (LiFEC)

Our study will be aimed to assess the electrophysiological differences/equivalences between ground and space conditions for EEG, VEP, ERG and OPs. Some of the well established data analysis algorithms will be used in order to extract the needed information. These will include weighted and moving averages, cross correlations, cluster analysis, principal component analysis, as well as spectral analysis (for example fourier, wavelets and autoregressive analysis).

Specific and novel contributions in data analysis are required when searching for, and studying LiFEC.

As opposed to evoked potential studies, in fact, the investigation of LiFEC is complicated by the impossibility of knowing the exact stimulus time and waveform morphology, so the identification itself of LiFEC is a demanding task.

Identification of LiFEC requires to work on the original (non-averaged) data, with the consequent need of extended care for the quite poor Signal to Noise Ratio (SNR) typical of these kind of signals. Because all VEP and OPs analysis algorithms are based on the knowledge of stimulus time (most of them also heavily rely on averaging) new algorithms using concepts from template analysis and single sweep analysis will then be designed. The approximate time stamp left by the cosmonauts by pressing the pushbutton after perceiving light flashes will be used to define the LiFEC searching time window.

Once LiFEC have been identified their morphology will be studied to find first a precise physiological time stamp in the waveform to be use in

the successive correlation with particle transit. Using this time stamp as trigger, averaging will become possible with the consequent great enhancement of SNR.

LiFEC morphology will be studied with respect to baseline VEP morphology, in order to extract all possible physiological information based on the vast amount of knowledge on VEPs.

Topographical analysis of the time evolution of electrophysiological parameters will provide information on the active cortical sites (Equivalent Sources ESs), thus permitting to correlate particle trajectories and electrophysiological changes in specific brain regions.

The final step of data processing (linking particles and LiFEC data) will rely on a description of the LiFEC dynamics at the different measured sites (electrodes) in the same coordinate system as the Si helmet. Equivalent Sources of LiFEC will also be transformed in the same system. Suitable methods will be designed in order to use the same coordinates also for the brain MRI images of each cosmonaut. Correlation between particles transits and the different components in the LiFEC and LiFEC's ES will finally be studied with the anatomical reference provided by the MRI.

Cortical OPs, as well as other EEG features, have been recently shown to be linked with visual information processing. Linear and non-linear analysis tools, in time and frequency domain, will then be specifically adapted and/or designed to retrieve from OPs-changes in space those information regarding possible modifications in visual processing correlated to the different environment and to light flashes perception.

6. Ground measurements

During the development of the system, many ground tests and measurements have to be performed to determine by electrophysiological methods the functional status of (retinal and cortical) visual mechanisms in baseline conditions (laboratory setting at sea level) for a comparison with the functional conditions during orbital operations. Concurrently other tests must be performed to define the optimal stimulation procedure.

For this purpose, the spontaneous EEG activity and the electrophysiological responses (VEP, ERG, OPs) to visual stimuli will be used to define (for each subject and in accordance with the international standards for visual function testing) [13-15] the baseline, stimulus-unrelated functional status of the brain as well as the stimulus/response function for physical properties of the stimulus such as luminance, adaptation, motion and contrast. The relative contributions of retinal and cortical structures/mechanisms will be determined.

The EEG is in fact a nonspecific overall index of functional status of the cortex and subcortical structures projecting to, and interacting with, cortex. The visual evoked potentials (ERG, VEP, OPs), on the other hand, relate to the psychophysics of vision and in controlled conditions can be understood in terms of retinal and/or brain excitability. Proper handling of the stimulus physical properties allows to selectively activate distinct functions/subsystems of visual system and a body of knowledge exists about the sources and regulatory mechanisms of these responses. The spontaneous variability of evoked phenomena covarying with the stimulus properties can be controlled and in selected conditions is independent of other factors, including vigilance. Practicable hypotheses exist about the functional roles of neurotransmitters [19-22].

Electrophysiological responses to visual stimuli can be noninvasively recorded in man only at retinal and cortical (scalp) levels. These recording restrictions are satisfactorily compensated for when stimulus properties are selected to functionally dissect the visual system. Two main classes of stimuli are used, notably:

- a. Changes in luminance, usually obtained by short, white (or monochromatic) flashes presented full-field or in spots. Stimulation under photopic or scotopic adaptation allows selective activation of

cone and rod receptors respectively, and the response correlates with intensity and stimulated retinal area, with saturation phenomena.

b. Patterned, isoluminant stimuli are bright and dark alternating checkers or vertical/horizontal bars with sharp edges or sinusoidal profile, that are presented with on-off modality or are reversed on a screen. This stimulation modality is consistent with the centre-surround organization of receptive fields throughout the visual system, and triggers in man electrophysiological responses dominated by the central 8-10° of retina. The response reflects the stimulus contrast and spatial frequency.

Transient and steady-state stimulations are possible with both patterned and unpatterned stimuli depending on the temporal properties of the stimulus [22-25].

The stimulus procedure that best suit our aims will then be defined. A set of ground based baseline measurements will finally be performed. The results will be compared with those obtained in orbit.

7. Biological dosimetry

7.1 Cytogenetic methods

As already pointed out in chapter 3, space radiation can be a major health risk to crews of long-term spaceflights, such as MIR and International Space Station Alpha. Active and passive dosimeters have been used for monitoring space radiation during each mission, and personal dosimeters readings are included into the astronauts personal files.

We present here some methods of biological dosimetry that could take a remarkable profit from the knowledge of the particle fluence as measured by the silicon detector of the ELFO program.

The importance of biological dosimetry in astronauts has been recognized, mainly for two reasons. First, the relative biological effectiveness of a mixed field of charged particles at different energies and masses is largely unknown; second, astronauts are exposed to space radiation while in a microgravity environment, and this stress condition could alter the usual response to ionizing radiation exposure. For these very reasons, NASA promotes research in the field of biological effectiveness of space radiation and is planning to perform routinely biodosimetry for each crewmember. Both the classical dicentric-counting method and the more recent chromosome painting have been used. Recently, results of the first biodosimetric measurements of space radiation have been reported [26], [27]. These data clearly demonstrates that space radiation produce efficiently chromosome aberrations (CA) in peripheral blood lymphocytes (PBL) of crewmembers, and indicates that the quality factor of space radiation is between 2 and 3.

When considering biodosimetry, it is important to draw a distinction between “physical absorbed dose” and “biologically relevant dose”. Ionizing radiation deposits energy inside biological targets, according to its energy and charge, and to chemical composition of the target. However, in some cellular components, primary damage is enzymatically removed or repaired and the damage remaining after such restitution determines any biological consequences. The residual damage is a measure of the biologically relevant dose, and this will be generally lower in normal healthy individuals than in those carrying genetic deficiencies, or other

stress factors (immuno-suppression, vitamin deficiency, old age and so on) affecting the repair pathway. Because DNA molecule is the critical radiation target, and any damage to DNA is repaired very efficiently, bio-indicators based on cytogenetics will measure biologically relevant dose.

Cytogenetic analysis of PBL is preferred for several reasons. PBL are easily obtainable and are present in great numbers circulating throughout the body. Cell-cycle distribution consists mainly of resting G_0 cells, and changes produced by radiation are therefore chromosome-type aberrations, whereas most chemicals are S-phase dependent and produce chromatid-type aberrations. CA are induced *in vivo* and *in vitro* at approximately the same extent, thus reference dose-response curves can be easily established for different radiation qualities.

Different types of CA can be used in order to establish absorbed dose through appropriate calibration curves. Dicentrics are generally used, because they are relatively distinct and straightforward to count, are quite specific for ionizing radiation, and the background frequency is very low (1-2 per 1000 PBL). Dicentric originates after break and exchange between two different chromosomes that rejoin to form a chromosome with two centromeres accompanied by an acentric fragment. This type of aberration is observed and analyzed with greater efficiency than any other type of aberrations and its frequency is generally used for estimations of dose [28].

The micronucleus assay appears a simpler cytogenetic technique and an alternative to the dicentric assay [29, 30]. This new system permits rapid analysis of a large number of blood samples from exposed individuals. It has been reported that micronuclei (MN) could originate from acentric chromosome fragments or whole chromosome that are not included in the daughter nuclei after nuclear division. In the micronuclei assay for biological dosimetry using the technique of Fenech and Morley [31] micronuclei can be scored only in those cells that have completed one nuclear division following stimulation by mitogen. These cells are recognized by their binucleate appearance after inhibition of cytokinesis by cytochalasin B. Micronuclei background frequency (from 6 to 50 micronuclei in 1000 binucleated cells) is higher than dicentrics, nevertheless in the dose range for clinical use (0,25-4 Gy) this high background value does not affect the validity of the measurement.

Most of the studies based on chromosome analysis have demonstrated that the dose-response curve for aberrations (dicentrics) following *in vivo* whole-body irradiation is similar to that obtained after *in*

vitro irradiation of lymphocytes [32]. Dicentrics and other structural chromosomal aberrations are induced in vivo and in vitro at approximately the same extent, thus reference dose-effect calibration curves can easily be established. These *in vitro* calibration curves formally describe the relative number of chromosomal aberrations or of micronuclei induced per unit dose of radiation (expressed in Gy) and serve as reference standards for estimating dose in persons having external exposures to radiations.

Reference curves for the induction of dicentrics in PBL by radiation of different qualities are known with great accuracy [33], and the dicentrics count is recognized as official biodosimetric test in many countries. This is, for example, the test provided by NPRB in Great Britain, who routinely perform biodosimetry for workers professionally exposed every time film badges show abnormal readings, or there is reason to suspect an overexposure not recorded by the badge [34].

The laboratories of INFN in Frascati determined the calibration curves for dicentrics and for micronuclei in human lymphocytes exposed to low LET radiations (X rays) and for doses up to 3 Gy and 6 Gy respectively (fig. 7) [35]. Reference curves have been measured on a large number of different subjects and provide results for dose estimate with a high degree of statistical significance.

However, dicentrics and micronuclei are unstable aberrations: as a result of cell division, they are eliminated from the lymphocyte pool according to the lymphocyte turnover or replenishment time, which is estimated at approximately 3 years. Therefore, dicentrics and micronuclei can be used to reproducibly quantify recent radiation exposures only. In addition, because of their instability, they will not be directly linked to the late radiation effects. On the other hand, stable CA such as translocations remain constant following exposure and are considered to be connected to late radiation effects, such as cancer [36].

They are very difficult to score by conventional microscopy and staining techniques, but the recent method of fluorescence *in situ* hybridization (FISH) makes now possible an easy and accurate analysis of symmetrical interchanges for biodosimetry [37]. Translocations present a higher background frequency (5-10 per 1000 PBL) than dicentrics, and reference curves have not yet been established with the same accuracy as for dicentrics.

Recently, NASA performed some measurements relative to the crew of MIR18 mission (two cosmonauts and one astronaut, 120 days on

MIR, 51.6° inclination orbit, 300 km average altitude) by dicentric counting [38] and by FISH [26,27].

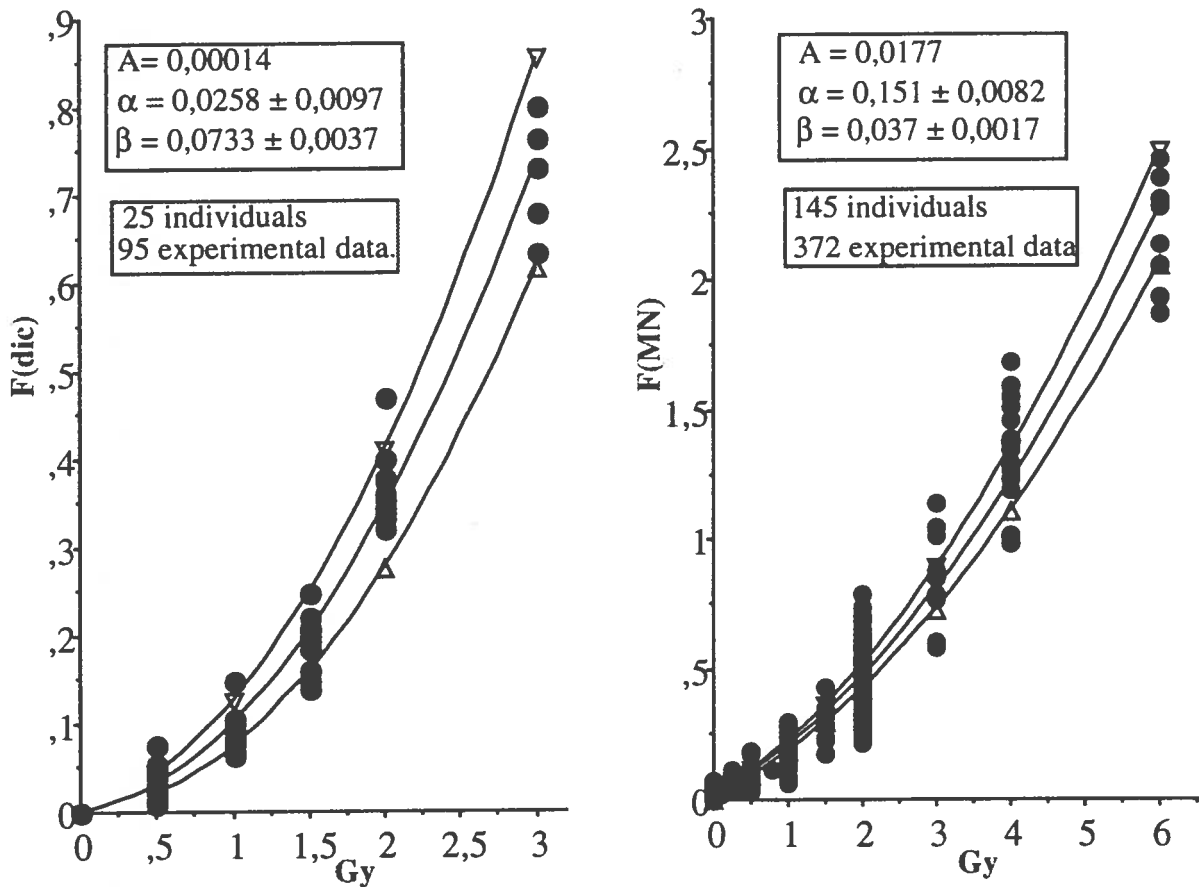

Fig. 7 : *In vitro* dicentric and micronucleus dose-response curves for human lymphocytes after X-ray treatment.

Individual calibration curves were measured pre-flight by *in vitro* exposure of astronaut blood to g-rays (fig.8). Aberrations in chromosomes 2 and 4 have been visualized by FISH, reciprocal exchanges (translocations plus dicentrics) only being used for biodosimetry. Dicentrics have also been analyzed. The post-flight aberration frequency has been measured and the equivalent dose directly estimated from the reference g-ray curve. An increase in aberration frequency was observed both by FISH and dicentrics analysis. Such increase is likely to be due to radiation rather than to chemical contaminants. In fact, concentration of clastogenic chemicals was very low aboard MIR; in addition, we determined sister chromatid exchanges (SCE) in lymphocyte samples harvested at the second post-stimulation mitosis. It is well known that SCE are efficiently induced

by chemical clastogens, but not by radiation. No difference were found in the frequency of SCE pre- and post-flight, suggesting that aberrations were indeed caused by space radiation alone.

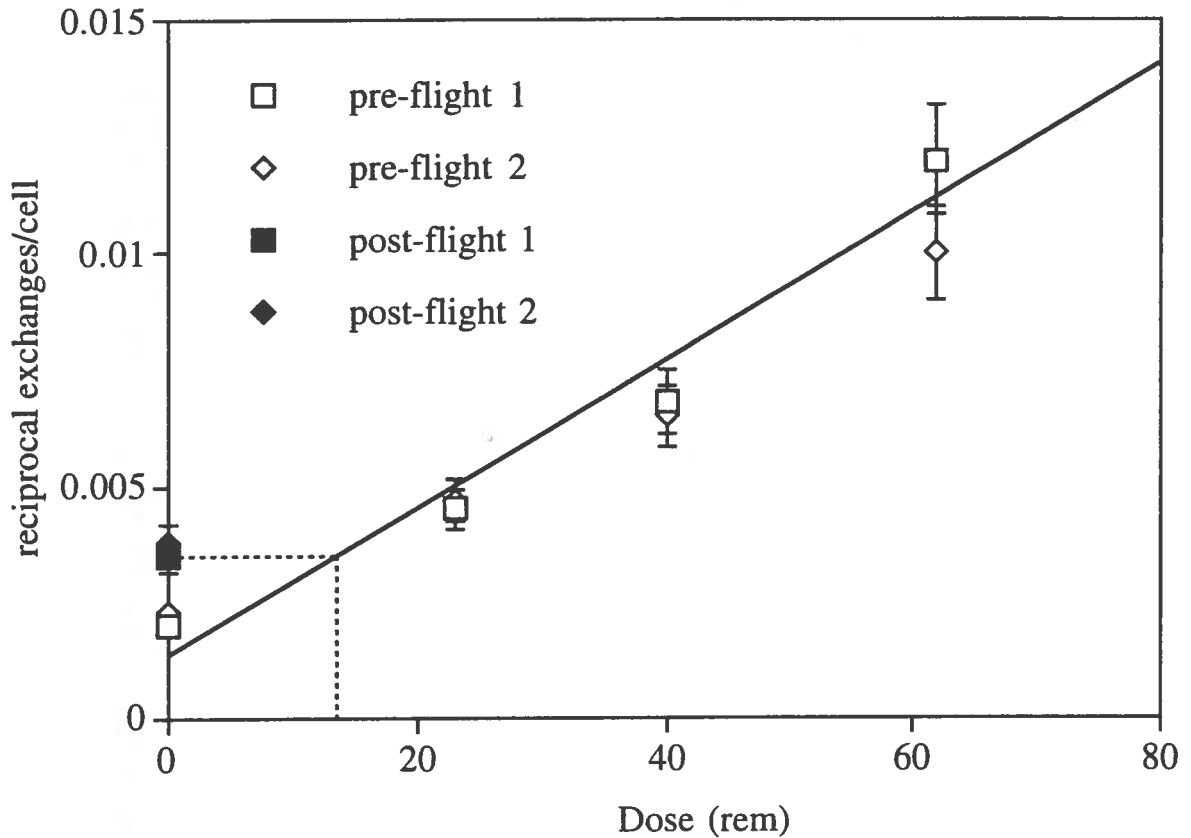

Fig. 8 : Biodosimetry of two crewmembers (1 and 2) of MIR18 mission.

**The reference pre-flight curve is obtained with g-rays [33].
Mission was about 4 months long.**

The absorbed dose received by crews during the mission was estimated to be about 145 mSv. Because the absorbed dose measured by physical dosimeters is 52 mGy for the entire mission, the weighting factor of space radiation on MIR will be about 2.8. Interestingly, this quality factor is higher than that estimated by the LET spectrum as measured by a tissue equivalent proportional chamber. This results indicate that an accurate estimate of the biological effectiveness of space radiation should be performed by direct biodosimetric measurements, because published quality factors cannot reproduce the complicated situations of space radiation and environment.

Another interesting result of this experiment has been the observation that the space environment produce a severe cell-cycle delay in lymphocytes. This delay is measured when lymphocytes are grown *in vitro* on the day of astronaut landing.

After about one week, the growth kinetics is faster but a full recover occur only after about one month on Earth. The growth delay causes a serious reduction in the mitotic index of the sample on the day of landing, which in case of lymphopaenia could make problematic any analysis of metaphase chromosomes.

Importance of biodosimetry has been acknowledged by NASA, and it is planned that all US astronauts involved in the Space Station program will be assayed from chromosomal aberrations pre- and post-flight by dicentrics and FISH analysis [39]. Russian space programs also aim to improve the biodosimetry tests already routinely performed in cosmonauts, in collaboration with other laboratories where the FISH method could be used [40].

7.2 Individual radiosensitivity

Current studies on the effects induced by ionizing radiations in living beings demonstrate that each organism presents a different radiosensitivity as regards to various physical and biological factors [41]. Individual radiosensitivity may influence the build up and the extent of the deterministic effects and the occurrence of the stochastic effects (leukemias and solid tumours).

The inter-individual variability of radiosensitivity has been measured as dicentric [42] and micronucleus yields [43] induced in human lymphocytes after *in vitro* X-ray treatment.

In recent years a number of procedures have been developed for improving detection of differences in yields of radiation-induced chromosome aberrations *in vitro* in cells of different individuals [44]. These include the use of G2 phase cells, micronucleus assays, low dose rate exposure and the examination of interphase cells using premature chromosome condensation.

In particular, the research group of INFN at Frascati conceived an experimental method based on observation of lymphocytes response (as micronuclei), after *in vitro* X-irradiation, with 3-aminobenzamide (3AB). 3AB is an inhibitor of the poly(ADP-ribose) polimerase. This enzyme can

affect the DNA repair activity in human lymphocytes [45], cause a manyfold increase in the frequency of both sister chromatid exchange (SCE), modify single strand breaks (SSB) repair after mutagen treatment [46], and increase chromosome aberrations [47]. Moreover the increased activity of the enzyme in the presence of DNA strand breaks induced by ionizing radiation exposure [48] is a further reason for supposing that it may affect the DNA repair process [49]. Therefore, the inhibition of DNA repair in human lymphocytes by 3AB may result in an enhancement of the cytogenetic response to radiation expressed as an increase of micronuclei ([50]. To calculate the effect of 3AB on X-ray response (micronucleus yields), the following relationship has been proposed:

$$I_{3AB} = 1 - \frac{MN_{-3AB}}{MN_{+3AB}}$$

where I_{3AB} is the 3AB-action index, MN_{+3AB} and MN_{-3AB} are the micronucleus frequencies obtained with and without 3AB, respectively. I_{3AB} tends to zero when the micronucleus frequency is the same with and without 3AB, thereby expressing a higher radiosensitivity (DNA repair or poly(ADP-ribose) polymerase activity reduced or absent). I_{3AB} tends to unity when the micronucleus frequency in the presence of 3AB (MN_{+3AB}) strongly exceeds the frequency without 3AB (MN_{-3AB}), thereby expressing a stronger resistance (DNA repair associated with greater synthesis of poly(ADP-ribose) polymerase).

This method can be applied also to astronauts to examine thoroughly the importance of individual response after exposure to space radiation.

7.3 Research design and methods

The radiobiological assays will be carried out from two Research Institutes: Biodosimetry Research Group (Dosime) of INFN in Frascati, Department of Biology "Roma Tre" University, Rome and the Department of Physics of "Federico II" University in Naples. A flowchart of the research design is outlined in fig.9. The blood is drawn in a Vacutainer from each astronaut, and can be processed in different ways. The pre-flight samples should be irradiated *in vitro* with low doses of X-rays in order to study

individual radiosensitivity: individual dose-response curves and 3AB-index.

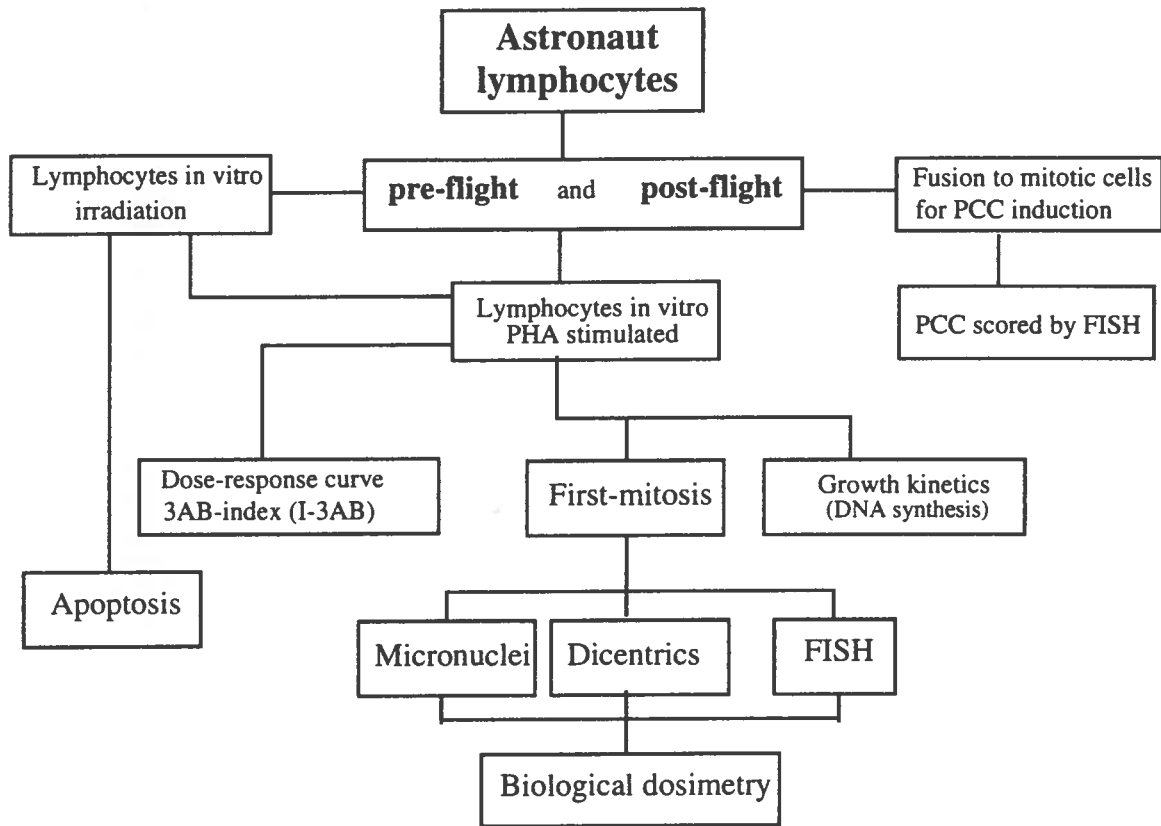

Fig

. 9 : Processing of astronaut blood for biodosimetry by different methods.

These assays will be also performed in the post-flight samples for evaluating an eventual modification of individual response to spaceflight conditions. Preliminary studies on astronauts suggest that individual radiosensitivity is similar in these healthy individuals, although the background frequency can vary with age and past exposure records. If that is the case, analysis of the background frequency alone could be sufficient, once the calibration curve is well known.

We propose to perform the radiobiological assays in about 20 subjects utilizing:

- 1) peripheral blood lymphocytes *in vitro* stimulated by phytoaeoagglutinin (PHA) to measure dicentric in metaphase, micronuclei in binucleated cells and translocations by FISH;
- 2) peripheral blood lymphocytes in interphase to measure chromosome aberrations after PCC induction.

Other measurements as the level of PHA stimulation (growth kinetic) and the programmed death (apoptosis) will be also considered.

An accurate study of the possible correlations between the obtained results and the kind of particle and energy released measured by ELFO in the same time will be performed.

8 . Concluding Remarks

In view of a permanent station in Earth orbit or on the Moon, radiation protection efforts must take into account that an increasing number of space workers, men and women of all age groups are expected to spend a substantial part of their time in space. Extravehicular activities will increasingly become a routine performance. Besides the proposed space station, special missions will bring workers to orbits of high altitude and high inclination up to polar orbits.

Future perspectives of man's endeavour in space include travelling to the planets of our solar system with Mars being the first candidate. In an expedition to Mars, the HZE particles of cosmic radiation and particles emitted during solar flares represent the major radiation hazard. Therefore, additional data on the biological effectiveness of HZE particles and an improved knowledge of the radiation situation inside space vehicles are urgently required, in order to secure man's safety in future long duration flights outside the Earth's magnetosphere or in high inclination Earth orbits.

References

- [1] Osborne W.Z., Pinsky L.S., Bailey J.W., In *Biomedical Results of Apollo* , NASA SP-368 (1975) 355.
- [2] Galper A., Ozerov Yu., Popov A., Zemskov V., Zverev V., Alexandrov A., Avdeev S., Shabelnikov V., Fuglesang C., Carlsson P., De Pascale M.P., Morselli A., Picozza P.G., Sparvoli R., Adriani O., Castellini G., Spillantini P., Barbiellini G., Boezio M. and Vacchi A., presented at the *Sixth European Symposium on Life Sciences Research in Space*, 17-21 June, Trondheim, Norway, 1996.
- [3] Avdeev S., private communication.
- [4] Fremlin J.H., *New Scientist* 47 (1970) 42.
- [5] Charman W.H., Dennis J.A., Fazio G.G. and Jelley G.V., *Nature* 230 (1971) 522 .
- [6] Budinger T.F., Bichsel H. and Tobias C.A., *Science* 172 (1971) 868.
- [7] Tobias C.A., Budinger T.F. and Lyman J.T., *Nature* 230 (1971) 596.
- [8] Charman W. H. and Rowlands C. M., *Nature* 232 (1971) 574.
- [9] McNulty J., *Nature* 234 (1971) 10.
- [10] Fazio G.G., Jelley J.V., Charman W.N., *Nature* 228 (1971) 260.
- [11] Tobias C.A., *J. Aviation Med.*, 23 (1952) 345.
- [12] McAulay I.R., *Nature* 232 (1971) 421.
- [13] Budinger T.F., Lyman J.T. and Tobias C.A., *Nature* 239 (1972) 209.
- [14] Hoffman R.A., Pinsky L.S., Osborne W.Z., Bailey J.V., In *Biomedical Results from Skylab*, NASA SP-377 (1977) 127.

- [15] Budinger T. F., Tobias C.A., Huesman R.A., Upham F.T., Wieskamp T. F., Schott J.U. and Schopper E., In Apollo-Soyuz Test Project Summary Science Report, NASA SP-412 (1977) 193.
- [16] Lipetz LE. Brit J Ophthlmol 39, 577, 1955
- [17] Niedermeyer E. and Lopes F.H. da Silva, Electroencephalography. Basic Principles, Clinical Applications and related Fields, Williams and Wilkins, Baltimore 1987.
- [18] Hämäläinen M., Hari R., Ilmoniemi R.J., Knuutila J. and Lounasma O.V., Magnetoencephalography-theory, instrumentation, and applications to noninvasive studies of the working human brain, *Rev. Mod. Phys.* 65 (1993) 413.
- [19] Frost J.D. Jr, In: Electroencephalography. Basic Principles, Clinical Applications and related Fields, ed. by E. Niedermeyer and F. Lopes da Silva. Williams and Wilkins, Baltimore 1993.
- [20] Frost J.D. Jr., Shumate W.H., Salamy J.G., Booher C.R., " Skylab sleep monitoring experiment (M-133)", Proc. of the Skylab Life Science Symposium, Washington, NASA TM X-58154 (1974) 239.
- [21] Badhwar G.D., Nachtwey D. S. and Yang T.C., *Adv. Space Res.* 12 (1992) 195.
- [22] Cracco RQ, Bodis-Wollner I eds. Evoked potentials. Alan R Liss Inc, New York, 1986
- [23] Heckenlively JR, Arden G eds. Principles and practice of clinical electrophysiology of vision. Mosley-Year, Chicago, 1991
- [24] Regan D., Evoked potentials in psychology, sensory physiology and clinical medicine, Chapman and Hall, London, 1972.
- [25] Regan D., Human brain electrophysiology - Evoked Potentials and Evoked Magnetic Fields in Science and Medicine, Elsevier, N.Y., 1989.

- [26] Yang T.C., George K., Johnson S., Durante M. and Fedorenko B., *Adv. Space Res.* (1996) in press.
- [27] Yang T.C., Durante M., George K., Johnson S., and Fedorenko B., *Radiat. Res.* (1996) in press.
- [28] IAEA, *Biological Dosimetry: Chromosomal Aberration Analysis for Dose Assessment* (STI/DOC/10/260, Vienna) 1986.
- [29] Catena C., and Righi E. *La Medicina del Lavoro* 84, (1993) 99.
- [30] Catena C., Conti D., Del Nero A., and Righi E. *La Medicina del Lavoro* 84 (1993) 133.
- [31] Fenech M., and Morley A.A., *Mutat. Res.* 147 (1985) 29.
- [32] Fabry L., Lemaire M. *Strahlentherapie* 162 (1986) 117.
- [33] Bender M.A., Awa A., Brooks A.L., Evans J., Groer P.G., Littlefield L.G., Pereira C., Preston R.J. and Wachholz B., *Mutat. Res.* 196 (1988) 103.
- [34] Lloyd D.C., Edwards A.A, Prosser J.S., Moquet J.E. and Finnon P., *Doses in radiation accidents investigated by chromosome aberrations analysis. XIX: review of cases investigated, 1988-1990.* National Radiological Protection Board, Chilton 1991.
- [35] Catena C., Conti D., Parasacchi P., and Righi E., In: *Nuove Metodologie di dosimetria biologica applicabili alla protezione della salute dell'uomo.* Rapporto Tecnico INFN LNF-95/017 (IR),1995.
- [36] Gray J.W., Lucas J., Kallioniemi O., Kuo W. L., Straume T., Tkachuk D., Tenjin T., Weier H.U. and Pinkel D., In: B.L.Gledhill and F.Mauro (eds.) *New Horizons in Biological Dosimetry* (Wiley-Liss, New York) 1991, pp. 399-411,
- [37] Tucker J.D., Ramsey M.J, Lee D.A. and Minkler J.L., *Int. J. Radiat. Biol.* 64 (1993) 27.
- [38] Reitz G., Beaujean R., Hecvkeley N. and Obe G., *Clin. Investig.* 71 (1993) 710.
- [39] Yang T.C., NASA JSC Radiation health program. *Space Radiation Damage and Biodosimetry Workshop*, Houston, Sept. 9-10, 1996.

- [40] Petrov V.M., Present and future radiation dosimetry for russian cosmonauts. *Space Radiation Damage and Biodosimetry Workshop*, Houston, Sept. 9-10,1996.
- [41] Granier R. and Gambini D.J., In: *Applied radiobiology and radiation protection*. Ellis Horwood Limited, 1990
- [42] Lloyd D.C. and Edwards A.A., In: *Chromosomal Aberration*. Edited by Obe-Natarajan (Spinger-Verlag, Berlin) 1990 pp. 212-223.
- [43] Huber R., Braselmann H. and Bauchinger M., *Radiat. Environ. Biophys.* 28 (1989) 113.
- [44] *Workshop Report*, Second L.H. Gray Workshop, Hamilton Hall, University of St Andrews, Scotland, 9-12 September 1991
- [45] Bohr V. and Klenow H., *Biochem. Biophys. Res. Commun.*, 102 (1981) 1254.
- [46] Waters R., Ramsay F. and Barrett I. *Carcinogenesis*, 3 (1982) 1463.
- [47] Natarajan A.T., Csukas L., Degrassi F., Van Zeeland A.A., Palitti F., Tanzarella C., De Salvia R. and Fiore M., In: A.T. Natarajan et al. (Eds), *Progress in Mutation Research*, (Elseviers, Amsterdam) 1982, pp. 47-59.
- [48] Cleaver J.E., Milam K.M. and Morgan W.F. *Radiat. Res.* 101 (1985) 16.
- [49] Sweigert S.E., Marston J.M. and Dethlefsen L.A.. *Int. J. Radiat. Biol.* 58 (1990) 111.
- [50] Catena C., Conti D., Del Nero A. and Righi E. *Int. J. Radiat. Biol.* 62 (1992) 687.