

ISTITUTO NAZIONALE DI FISICA NUCLEARE

Sezione di Milano

INFN/TC-97/01

7 Gennaio 1997

G. Battistoni, D.V. Camin, N. Fedyakin, G. Pessina, M. Sironi:
**CRYOGENIC PERFORMANCE OF MONOLITHIC MESFET PREAMPLIFIERS
FOR LAr CALORIMETRY**

Presented at the 4th Int. Workshop on GaAs and Related Compounds,
Aberfoyle, Scotland, 3-6 June 1996

*SIS-Pubblicazioni
dei Laboratori Nazionali di Frascati*

**CRYOGENIC PERFORMANCE OF MONOLITHIC MESFET
PREAMPLIFIERS FOR LAr CALORIMETRY**

G. Battistoni, D.V. Camin, N. Fedyakin, G. Pessina and M.Sironi.
*Dipartimento di Fisica dell'Universita' and Sezione di Milano dell'INFN,
20133, Milano, Italy*

ABSTRACT

A monolithic dual-channel preamplifier chip for LAr calorimetry has been designed in three "flavours". Four wafers containing about 500 units have been fabricated and the best flavour was carefully evaluated to establish the yield and the uniformity of the process at cryogenic temperatures. The results of this evaluation are presented.

1. - INTRODUCTION

GaAs based front-end electronics for particle detectors was used for the first time in real physics experiments with bolometric detectors^(1,2). Later-on its use in noble-liquid calorimetry was proposed and, at an early stage, a small number of hybrid circuits carrying discrete MESFETs were used with the prototype of the LAr Accordion calorimeter⁽³⁾. Detector capacitances of a few hundred picofarads in the prototype required for FETs with large gate-width for better matching. MESFETs with 12000 μm gate-width were designed and fabricated using a commercially available, ion-implanted MESFET process⁽⁴⁾. For the first time, a thermal noise density of 0.2 nV/ $\sqrt{\text{Hz}}$ was measured in FETs immersed in liquid nitrogen (LN) by connecting two 12000 μm devices in parallel. The equivalent input capacitance was 120 pF⁽⁵⁾.

Following the development of these large gate-width FETs, integrated monolithic preamplifiers with external feedback components were designed and fabricated. Several hundred channels of the LAr Accordion prototype and a fine-grained preshower detector have been read out with GaAs monolithic preamplifiers designed specifically for the purpose. An improvement of noise by a factor 1.5 to 2, was demonstrated⁽⁶⁾ compared with previous solutions used. The results from a test beam set-up confirmed expectations of superior noise and speed performance of this technology in a wide, low-temperature range which includes LAr (87 K), LKr (120 K), and LXe (150 K). In fact, at shaping times of tens to a few hundreds of nanoseconds, the dominant noise is white as the 1/f noise becomes negligible if the device is cold. This is not the case at room temperature when 1/f noise frequently dominates even at short shaping times. In addition, the large gain-bandwidth product (GBW) allowed low dynamic input resistances of 3 to 10 Ω to be achieved, which is beneficial in reducing cross-talk by providing a small input time constant. More recently, monolithic circuits specially designed to readout the middle and back segments of the ATLAS electromagnetic calorimeter have been fabricated. The main purpose of the fabrication run was to evaluate the feasibility of producing in the near future a large number of highly reliable chips to equip the whole detector (~50000 channels). We wanted to evaluate the uniformity of noise, gain and speed of the chips fabricated in the four wafers of a single foundry run. Considering the severe environmental conditions imposed by the planned long term operation of ATLAS, (about 10 years without access to the cryostat), we also looked at reliability issues.

In section 2 we describe the new chip developed. In section 3 we give details of the chip fabrication. In section 4 we present the results of evaluations independently performed at Milano and at BNL. In section 5 we discuss reliability issues and present radiation damage results.

2. - MONOLITHIC COLD PREAMPLIFIER CHIP

The building block of the cold read-out circuit proposed for ATLAS is a monolithic dominant-pole amplifier (DPA) fed back as a current-to-voltage converter. The feedback network consists of a resistor R_F in parallel with a capacitor C_F , both elements external to the chip, with values optimized for each calorimeter compartment and for the whole range of pseudorapidity η covered by the barrel detector. The time constant $C_F R_F$ is set to ~ 20 ns and R_F is chosen to handle the maximum detector current, which can reach 8 mA, with value ranging from 430Ω to $1.5 \text{ k}\Omega$ (7).

The chip was designed following previous experience(8). A large MESFET, $3 \times 24000 \mu\text{m}^2$ at the input, followed by a cascode loaded by a current source constitutes the gain stage. It is loaded by an intermediate buffer which is in turn followed by the output stage. The input transistor receives its bias current from a separate power supply VCO. In this way power dissipation is kept low despite the high dynamic range. The circuit diagram is shown in Fig. 1.

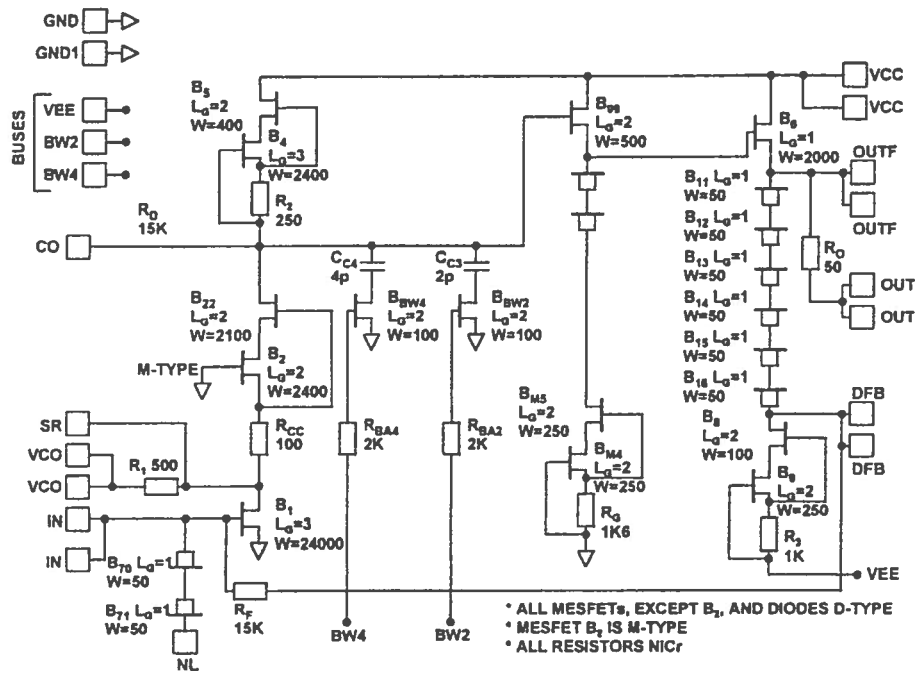

Fig. 1. Schematic diagram of the monolithic cryogenic preamplifier for noble liquid calorimetry.

3. - FABRICATION OF A SMALL PRODUCTION SERIES

Four 4" wafers carrying 480 dual-channel chips, as well as other projects, were fabricated using

an ion-implanted MESFET process⁽⁴⁾. Besides the circuit described in Fig. 1, two other "flavours" with a few differences with respect to the original design were also included. While all three flavours performed well, one was clearly superior and was later carefully evaluated.

Chips were assembled into dual-in-line (DIL) 18 pin ceramic packages using silvered epoxy for die attachment and 25 μm gold wire for ball-bonding. Two wires per contact were used in almost all connections to improve reliability further. Fig. 2 shows a micrograph of the assembled chip taken with a scanning electron microscope. Note the large area occupied by the input FET, of which a detail is shown in Fig. 3.

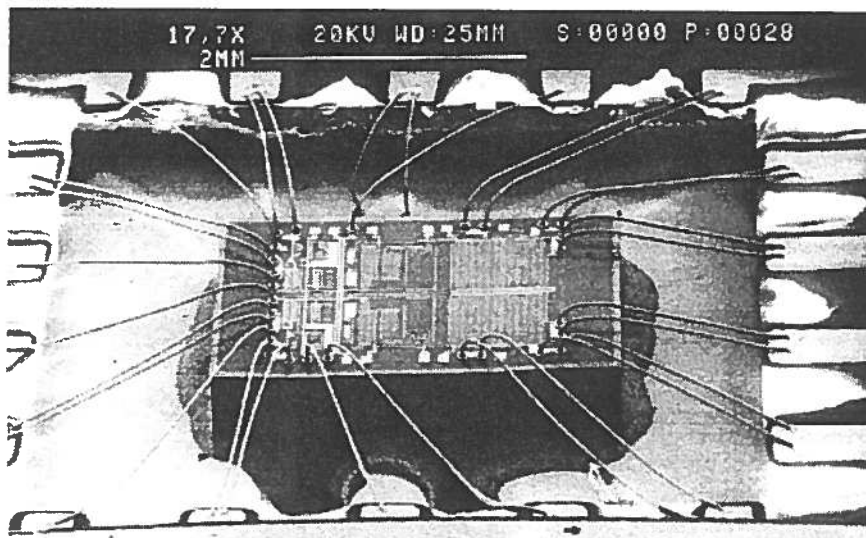

Fig. 2. Chips have been assembled into an 18 pin DIL ceramic package. The chip dimensions are $2.5 \times 1.5 \text{ mm}^2$ and each chip contains two channels. Two bonding wires per pad have been used in almost all contacts to improve reliability.

4. - EVALUATION OF CHIPS PERFORMANCE

Dice were subjected to visual inspection at the factory. 30 units of the selected chip flavour were manufactured in each wafer making a total of 120 chips; 15 dice did not pass visual inspection screening. Upon receiving assembled chips, we performed electrical tests and rejected two more faulty devices. The overall yield was therefore 86%.

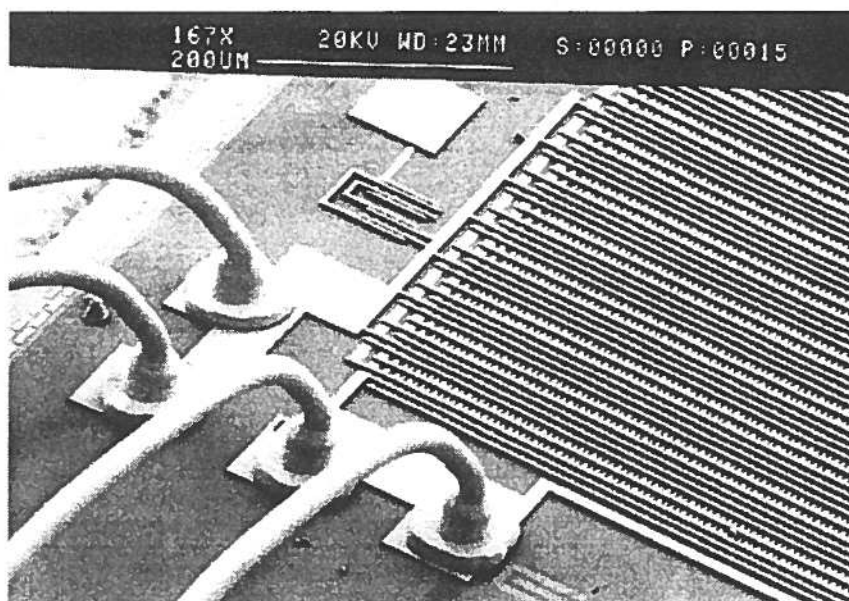

Fig. 3. A detail of the interdigitated input FET and double bonding.

For evaluation of chip performance, test PCB's were prepared simulating the read-out of two cells of the calorimeter. The PCB contains the feedback components, the capacitance simulating the detector and a DIL socket into which the chips under test are plugged. One of the two channels of the chip, channel A, "sees" an external capacitance $C_D = 1$ nF and its feedback network consists of $R_F = 820 \Omega$ in parallel with $C_F = 22$ pF. The second channel, B, sees $C_D = 2.2$ nF and has $R_F = 430 \Omega$ and $C_F = 56$ pF. A CR-RC² shaper followed the preamplifier, giving a bipolar pulse of amplitude V_o and peaking time (5% to 100%) t_p . An exponential current pulse with a time constant of 400 ns was applied as a test signal by using a step voltage generator and a series capacitor C_T and resistor R_T . C_T - R_T values were 47 pF and 8.2 k Ω respectively during noise measurements and 470 pF-820 Ω during linearity measurements.

4.1 - Noise

Preamplifier noise is expressed as Equivalent Noise Current (ENI) by referring it to the amplitude of the test signal current. In Fig. 4 we present a plot of ENI vs t_p for $C_D = 1$ nF and $C_D = 2.2$ nF. A straight line with the expected $t_p^{-1.5}$ law is plotted as an guide to the eye.

From ENI measurements, the value of preamplifier series noise was extracted. Good agreement was obtained with direct measurement of the series noise density made with a spectrum analyzer. The result of one such measurement is plotted in Fig. 5. It must be noted that for $t_p = 40$ ns the band center is at ~ 8 MHz where the noise density is ~ 0.35 nV/ $\sqrt{\text{Hz}}$. Also, there is a roll-off at high frequencies which is possibly due to imperfect measurement of the noise transfer function.

One interesting result found was that the series noise density varies as the channel bias current I_D raised to the power $-1/4$, which demonstrates that the noise is contributed mainly by the input FET. In fact, the noise spectral density is inversely proportional to the square root of the FET transconductance which in turn is proportional to $\sqrt{I_D}$. The second-stage noise contribution, noticeable in a previous monolithic circuit realized for LAr calorimetry⁽⁸⁾ was this time strongly suppressed. To correlate noise with process parameters, the value of series noise density e_n was plotted as a function of the channel resistivity RSD, as shown in Fig. 6. The results for this foundry run, (NOV 95), are in good agreement with previous runs and confirm that, for cold operation, the noise density of MESFETs and its dependence with temperature are smaller for lower channel resistivity (higher doping).

The correlation of noise with wafer resistivity suggests that a limited freeze-out takes place when the channel doping is lighter. This can also be seen in Fig. 7, which shows a plot of $\gamma = R_n \times g_m$, where R_n is the noise resistance and g_m the transconductance of the FET.

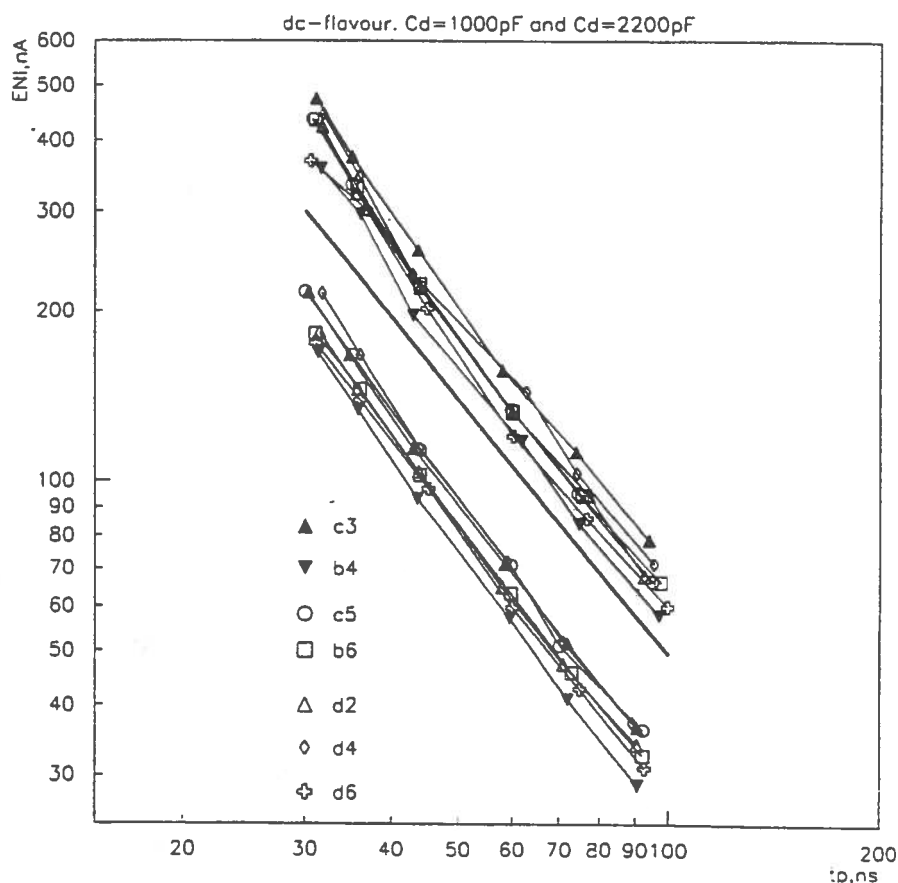

Fig. 4. Equivalent Noise Current (ENI) versus peaking time for seven chips of wafer # 39. The straight line with -1.5 slope is a guide to the eye.

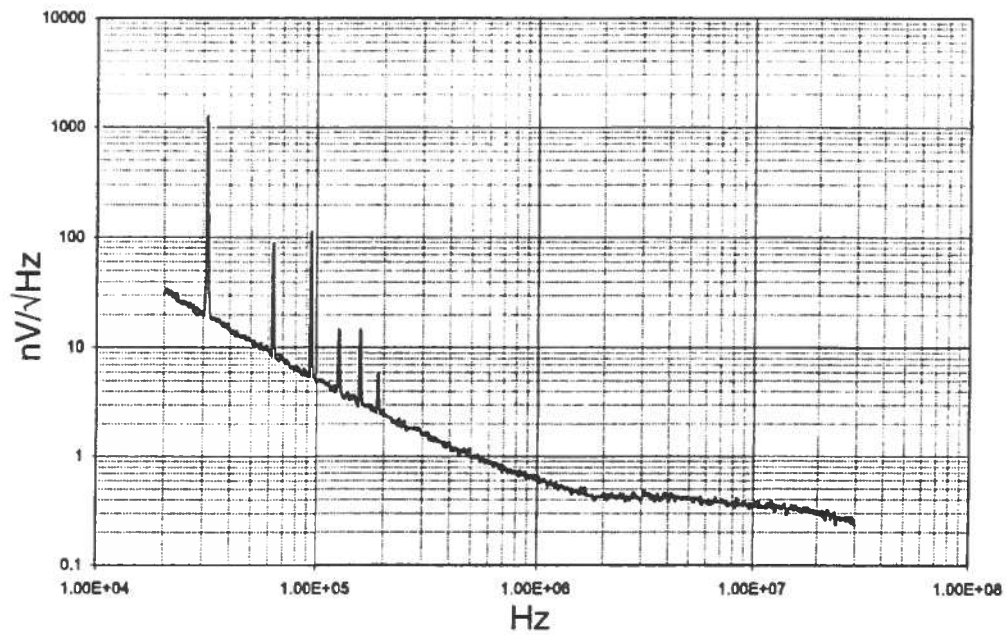

Fig. 5. Series noise spectral density of preamplifier # 8 of wafer # 40.

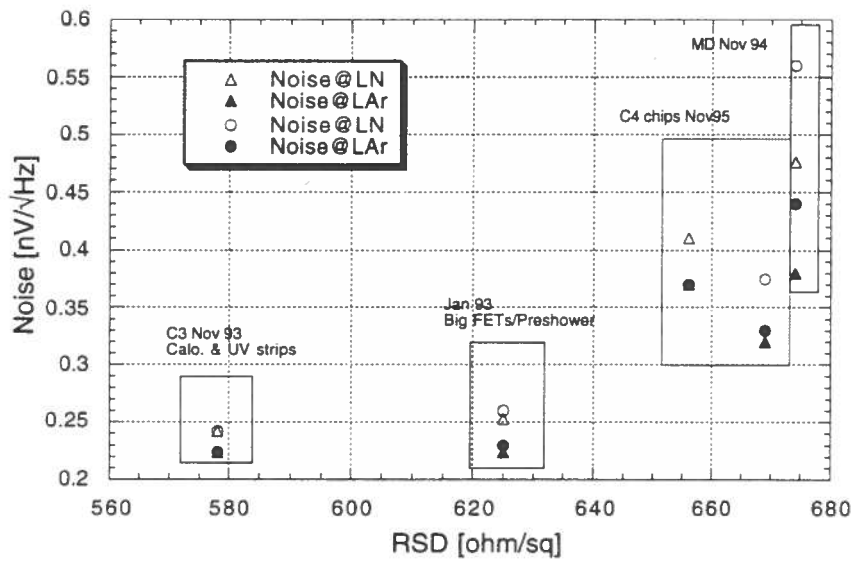

Fig. 6. Noise spectral density of MESFETs made in various foundry runs, at 77 K and 87 K as a function of channel resistivity.

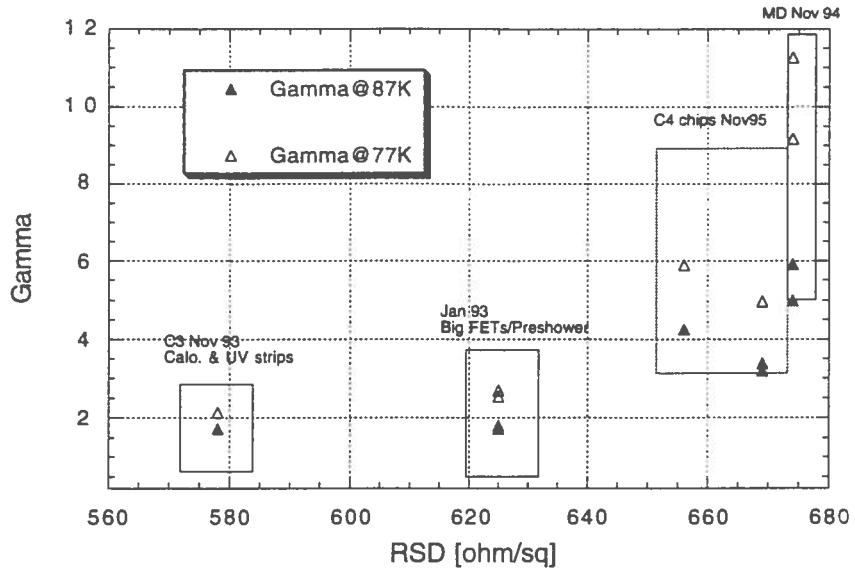

Fig. 7. Plot of $\gamma = R_n \times g_m$ as a function of channel resistivity.

4.2 - Uniformity of the process characteristics

Systematic measurements of ENI, t_p and V_O were performed independently by Milano and BNL teams on all four wafers. Wafer # 38 and # 40 were measured at BNL and wafers # 39 and # 41 at Milano. In Table 1 the mean values and dispersions for the four wafers are presented. There is good agreement between measurements at the two Labs.

Table 1. Results of evaluation of performance uniformity at 87 K in the four wafers

W#	Peaking Time t_p [ns]		ENI at t_p [nA]		Amplitude [mV]	
	$C_D = 1\text{nF}$	$C_D = 2.2\text{ nF}$	$C_D = 1\text{nF}$	$C_D = 2.2\text{ nF}$	$C_D = 1\text{nF}$	$C_D = 2.2\text{nF}$
38	40.0±1.3	40.1±1.0	114±13	222±33	287±8.9	268±13
39	39.9±0.5	40.2±1.4	101±4.8	222±20	281±7.8	269±9.0
40	40.0±0.6	39.3±2.2	101±12	204±19	287±9.5	267±9.4
41	40.3±1.1	39.2±1.2	100±10	211±22	289±4.8	266±9.6

4.3 - Response to large signals

To evaluate the possibility of handling large detector currents with good linearity, measurements were made in the following conditions: $C_D = 1\text{ nF}$; $I_{\text{max}} = 4\text{ mA}$ and $C_D = 2.2\text{ nF}$; $I_{\text{max}} = 8\text{ mA}$. Integral nonlinearity (INL) was determined to be less than 0.6%. An oscillogram of the response to an exponential current test pulse with an amplitude of 9.8 mA is shown in Fig. 8. The feedback resistor is $R_F = 430\ \Omega$. The load resistor is $50\ \Omega$. The main electrical parameters of the monolithic chip immersed in LAr are given in Table 2.

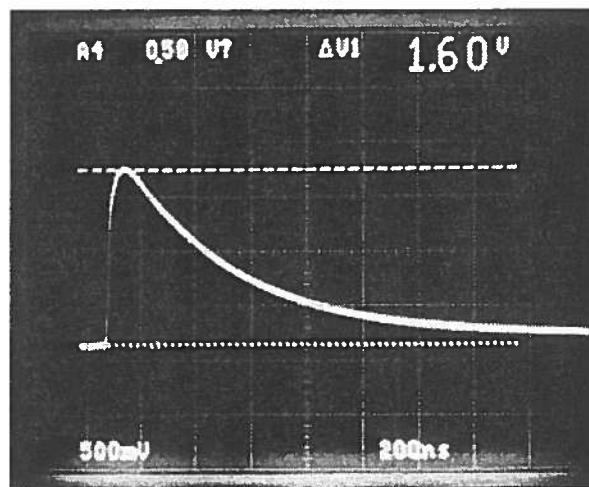

Fig. 8. Signal response to a 9.8 mA exponential test current, on a 50 Ω load.

5. - RELIABILITY ISSUES

The monolithic preamplifiers described in this work were designed for the LAr barrel calorimeter of ATLAS. Access to the elements inside the cryostat is not foreseen during the 10 years of the experiment. The inaccessibility of the detector components inside the cryostat for such a long time puts severe requirements on system reliability. Connectors, mother boards, resistors and capacitors will be subjected to mechanical stress during thermal cycling (filling and emptying the cryostat with LAr). Active devices must withstand thermal and also electrical stresses that may provoke charge trapping (which appears as a change in the device characteristics). High voltage discharges could destroy the device if it is not protected with an adequate network. Devices must also be radiation hard to 500 Gy and $2 \times 10^{14}\text{ n/cm}^2$. All these aspects have been given due attention.

Table 2. Main parameters of the monolithic C4-DC chip at 87 K

GBW Product (compensated)	1.7 GHz
Series White Noise	0.33 ± 0.015 ¹ to ± 0.045 ² nV/ $\sqrt{\text{Hz}}$ (1: for wafer #39; 2 for wafer # 38)
Corner Frequency of 1/f Noise	0.8 MHz
Dynamic Range	3 V with 0.6% INL
Power Dissipation	70 mW

Charge trapping was not observed in TriQuint's FET's nor in Vitesse FET's which are also ion-implanted devices of similar characteristics to TriQuint's.

Mechanical stress effects were checked by subjecting 7 chips and a set of passive components to ~700 thermal shock cycles from + 50 °C to 77 K, every 50 sec. No failures were detected in the chips. In a few cases, at the end of the test, a tiny crack was noticed in the ceramic lid, which suggested the use of a metallic lid as a better solution. The most noticeable damage was in the cables used in the test jig.

As for high voltage discharges, a protection network consisting of 3 zener diodes, 1 SMD inductor and 1 resistor, was designed and evaluated. Tests were performed confirming that the network is effective in protecting the chips against energy absorption of 6 mJ.

Regarding radiation damage, Fig. 9 and Fig. 10 show recent results on neutron irradiation of FET's fabricated with the same foundry process used for the realisation of the monolithic preamplifiers. These results confirm previous findings that ion-implanted GaAs MESFET technology is suitable for this application⁽¹⁰⁾.

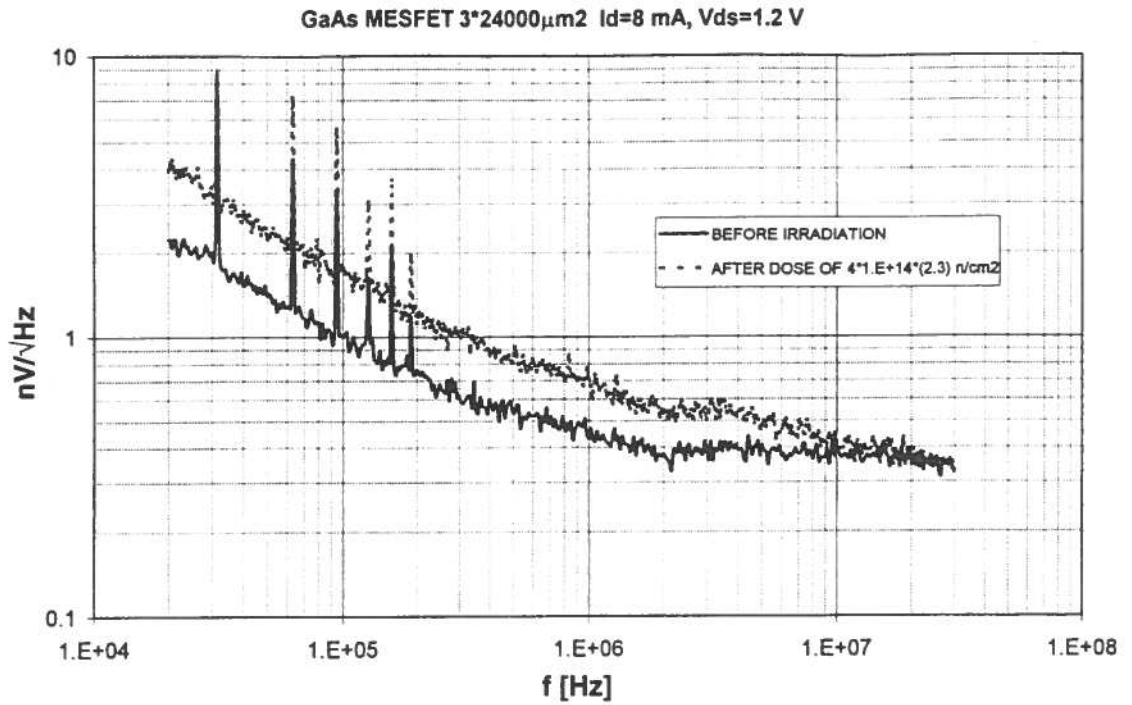

Fig. 9. Noise spectral density of a 3 x 24000 μm^2 MESFET before and after irradiation with neutrons. Given in parentheses is the conversion factor for GaAs equivalent fluence at 1 MeV.

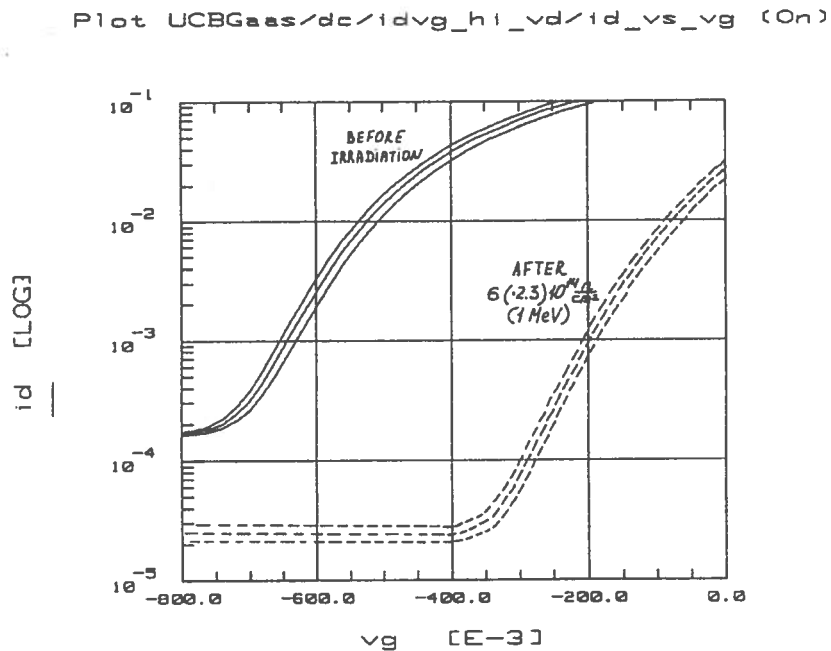

Fig. 10. Shift in a MESFET threshold voltage after neutron irradiation.

6. - SUMMARY AND CONCLUSIONS

Monolithic preamplifiers made with GaAs MESFET technology have been used to read out several hundreds of channels of the LAr Accordion calorimeter prototype at CERN. The electronic noise of current-sensitive monolithic preamplifiers is a factor 1.5 - 2 lower than alternative readout options. The large GBW enables input resistances of a few ohms for lower cross-talk and small signal integration. MESFETs have their best performance in the 77 K to 150 K range, where the $1/f$ noise corner frequency is lower than 1 MHz, and are therefore suitable for applications in noble-liquid calorimetry.

Recent experience of fabricating almost 500 monolithic preamplifiers of a new design gave satisfactory results. The fabrication yield was very high: ~86%. In the four wafers fabricated, amplitude and timing dispersion was below 5%. Integral-nonlinearity for the full signal excursion (8 mA, 3 V at the output) was 0.6%. Series noise was $0.33 \text{ nV}/\sqrt{\text{Hz}}$ with $\pm 5\%$ to $\pm 15\%$ dispersion. The noise level agrees with the expected value according to the resistivity of the wafers. We believe that the cryogenic performance of the selected process is now fairly well understood.

Tests performed to evaluate thermal stress damage showed that chips can survive at least 5000 chips x cycles. Recent results on radiation damage confirm previous findings about the hardness of GaAs technology at least at the level foreseen in ATLAS barrel calorimetry.

7. - ACKNOWLEDGEMENTS

We are specially grateful to M. Citterio and S. Rescia of Brookhaven National Laboratory for their effort to make a large number of accurate evaluation measurements in a very short time.

REFERENCES

- 1) A.Alessandrello et al., "Considerations on Front-End Electronics for Bolometric Detectors with Readout", Proc. of the Workshop on Low Temperature Devices for the Detection of Low Energy and Dark Matter, Ed: G.Pretzl, *Springer Verlag*, Berlin-Heidelberg (1987).pp122-143
- 2) A.Alessandrello et al., *Physics Letters* , **B 247**(1990) pp.442-447.
- 3) B. Aubert et al., *Nucl. Instr. and Meth*, **A309** (1991) pp.438-449.
- 4) QED/A by TriQuint Semiconductor Inc, Portland , Oregon , USA.
- 5) D.V.Camin et al., *IEEE Trans. on Nucl. Sci.*, **41**, No. 4, (1994) pp 1260-1266.
- 6) RD3 Collaboration, "Performance of Monolithic Current-Sensitive Preamplifiers with an Accordion LAr Calorimeter", in Proc. of the V International Conference in High Energy Physics, Brookhaven National Laboratory, September 15 to October 1, 1994.Ed: H.A.Gordon and D. Rueger, World Scientific (1995) pp. 401-409.
- 7) D.V. Camin et al., Cryogenic Front-End Electronics in III-V Technology for Liquid Argon Calorimetry in: Proc. of the First Workshop on Electronics for LHC Experiments (Lisbon, Sept. 1995), 257 (CERN/LHCC/95-96, 1995).
- 8) D.V. Camin et al., *Nucl. Instr. and Meth.*, **A 360**, (1995) 153.
- 9) Y. Christoforou, private communication.
- 10) M. Citterio, et al., Radiation Effects On Front-End Electronics For Noble Liquid Calorimetry, in: Proc. Fifth Intl. Conf. on Calorimetry in HEP (eds: H.Gordon and D. Rueger, BNL, Sept.1994), 401 (World Scientific, Singapore, 1995).