

ISTITUTO NAZIONALE DI FISICA NUCLEARE

Sezione di Milano

INFN/TC-94/06
26 Aprile 1994

Danilo Giugni, Ferdinando Mariani, Andrea Garagiola:

**PHOTOTUBES SUPPORT STRUCTURE FOR THE PROTOTYPE OF THE
BOREXINO DETECTOR**

PHOTOTUBES SUPPORT STRUCTURE FOR THE PROTOTYPE OF THE BOREXINO DETECTOR

Danilo Giugni, Ferdinando Mariani, Andrea Garagiola
INFN – Sezione di Milano, Via Celoria 16, I-20133 Milano, Italy

The prototype (CTF) of a massive scintillator detector, Borexino, devoted to e real time detection of low energy solar neutrinos, is going to be installed at the Laboratory of Gran Sasso.

Background problems force non standard solution for all the mechanical structure inside the detector. In particular here we describe the mechanical solution for supporting the 100 photomultipliers devoted to the detection of the scintillator light.

1. INTRODUCTION

The proposed Borexino detector is a scintillator detector to be installed at Gran Sasso (AQ) Laboratory devoted to the detection of the low energy Solar neutrinos. The monoenergetic neutrino flux (0.862 MeV) produced in the ${}^7\text{Be}$ electron capture reaction occurring in the solar core is the main candidate flux to be measured by the detector via ν -e scattering reaction in the liquid scintillator.

The performance of the detector itself is strongly related to the level of the background due, in mainly, by the natural radioactivity in the construction material of the detector.

Before the construction of the detector Borexino we are installing at Gran Sasso a prototype called C.T.F (Counting Test Facility) to study the background.

This detector is smaller then Borexino and has 4 Tons of liquid scintillator (100 Tons in Borexino) shielded by 1000 Tons of ultrapure water (10^{-13} g/g U,Th). The light is detected by 100 phototubes disposed all around the inner vessel that contains the scintillator. In Fig. 1 is shown the entire detector.

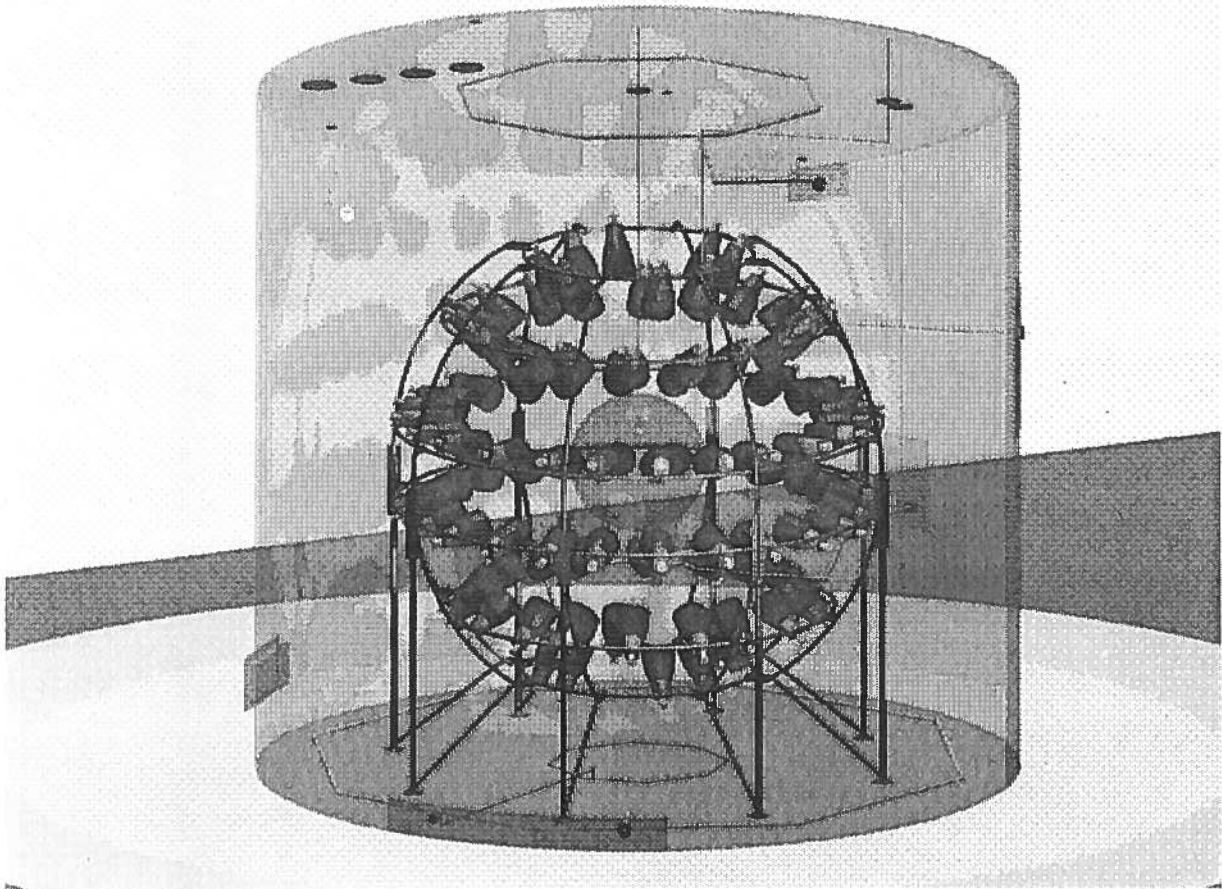

Fig 1. — C.T.F detector. Here the water tank and the Inner Vessel which contains the liquid scintillator is shown. The barrel structure that support the 100 PMT's, which is the objet of this paper, is well visible too.

In this paper we describe the engineering of the barrel structure devoted to support the 100 PMT's which have not a negligible weight with respect to the Wight of the structure itself. Furthermore the deformation induced by the PMT's weight could be a serious problem for the optical alignment of the PMT.

In fact the alignment, which is carried out by a laser technics, will be made before filling the tank with water and the variation of the load because the buoyancy of the PMT's could move the PMT and decrease the light collocation. The choice of the material and the cleaning process of the structure is very important too for the background.

2. THE RING STRUCTURE

The structure (Fig. 2) that has been chosen to support P.M.T. is an open structure made from six rings built by rolled tubes, and from eight meridians that come out from the eight legs of the structure. It is assembled with 60.32 mm diameter and 2.5 mm thickness tubes (Stainless steel Aisi 304) with a total weight of 827.4 Kg.

The octagonal symmetry is due to the fact that in the tank the layout of the straps is octagonal.

The 100 P.M.T.s will be fastened on the rings in the points shown by the green arrows.
To evaluate the deformation of the structure and the stress induced by PMT's we used a finite element analysis.

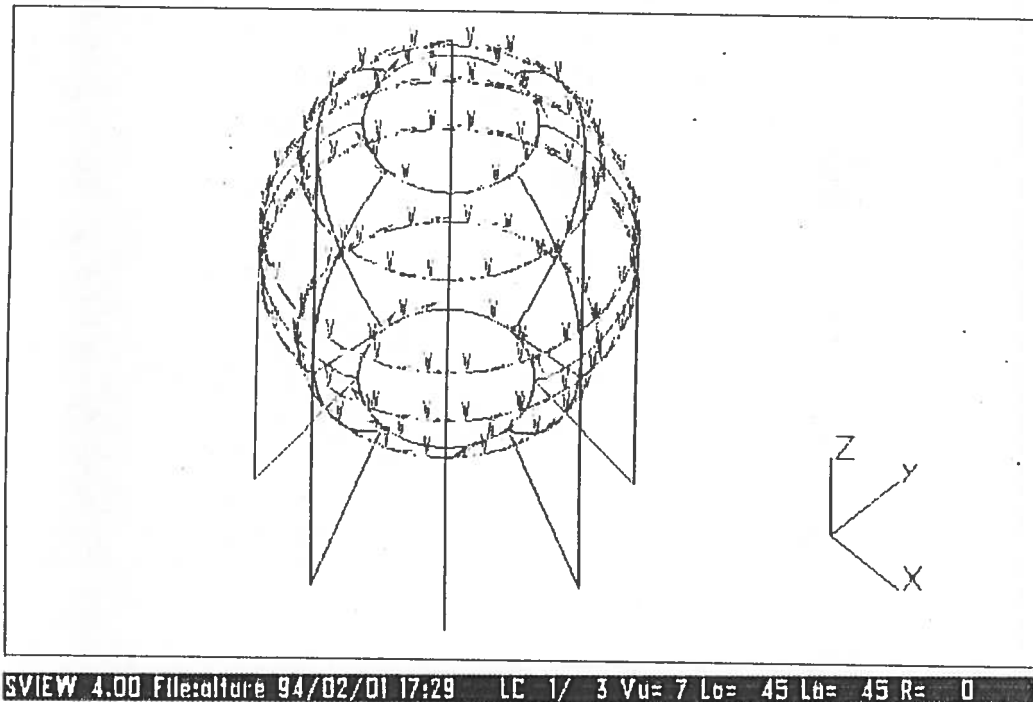

Fig. 2

3. THE STRESS ANALYSIS

It has been made a calculation of the stress and deformation by a software based on finite element method called Supersap.

The 100 P.M.T.s have been simulated with 100 forces (green arrows) of 10 Kg each and 100 torque's of 10000 Kgmm each. The centre of mass of the single PMT has been supposed located at 1 m far the clamping point. Special attention has been paid in the determination of the rotation of the supporting rings due to elastic deformation of the tubes. The constraint to the maximum rotation is bound to the fact that the P.M.T. must be aligned to the centre of the detector with an error of only 1°. This constraint come out from optical considerations.

The worst situation about alignment happens when the P.M.T.s are not plunged in the water. In fact the buoyancy is less than the weight of the P.M.T., for this reason the stress and deformation, which we have calculated without water, are the worst.

On the following we list the mechanical characteristics of stainless steel Aisi 304 chosen for the construction of the structure.

Stainless steel mechanical characteristic

Young's Modulus = $2.12E+04 \text{ Kg/mm}^2$

Poisson's Ratio = 0.3

Weight Density = $7.88E-06 \text{ Kg/mm}^3$

Geometrical barrel characteristic

$A=453.96 \text{ mm}^2$	(section area)
$J_1 =379861.3\text{mm}^4$	(torsional resistance)
$I_x=189930.7\text{mm}^4$	(flexural inertia local element axis x)
$I_y=189930.7\text{mm}^4$	(flexural inertia local element axis y)
$S_x=6299.5\text{mm}^3$	(section modulus local element axis x)
$S_y=6299.5\text{mm}^3$	(section modulus local element axis y)
$R_x=20.454\text{mm}$	(central inertial core radius)
$R_y=20.454\text{mm}$	(central inertial core radius)

4. RESULTS

The deformed structure is showed in Fig. 3 and in Fig. 4. The deformation is due to P.M.. and to the weight of the structure, of course the scale of deformation has been amplified.

From data analysis we get that the maximum shifting along Z axis is of **0.575 mm** and it happens on the higher ring.

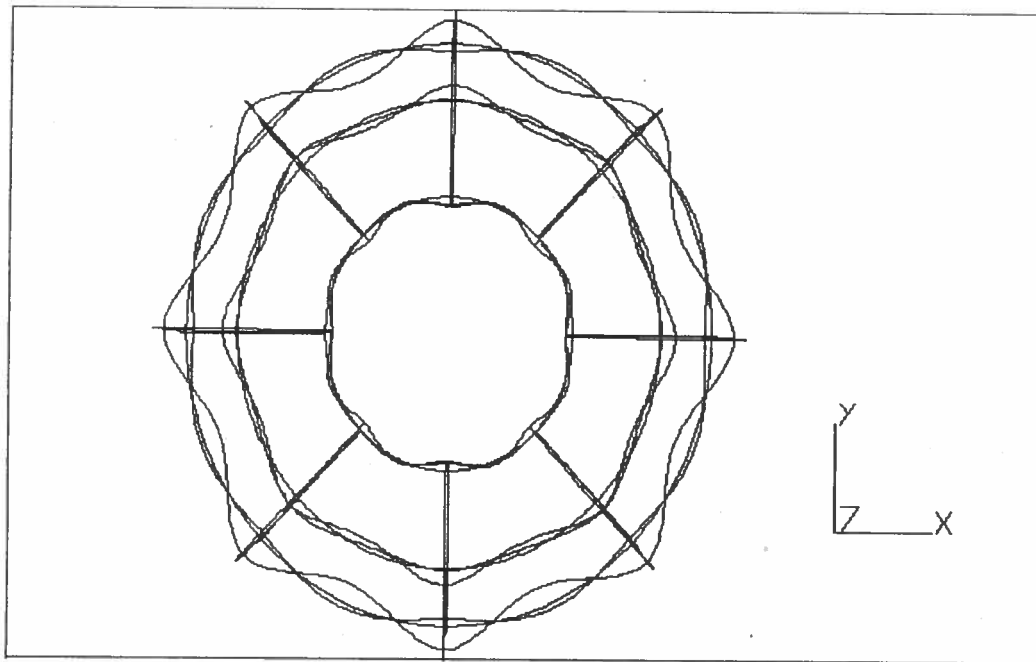

Fig. 3 — Deformation on the structure amplified 2000 times. TOP VIEW.

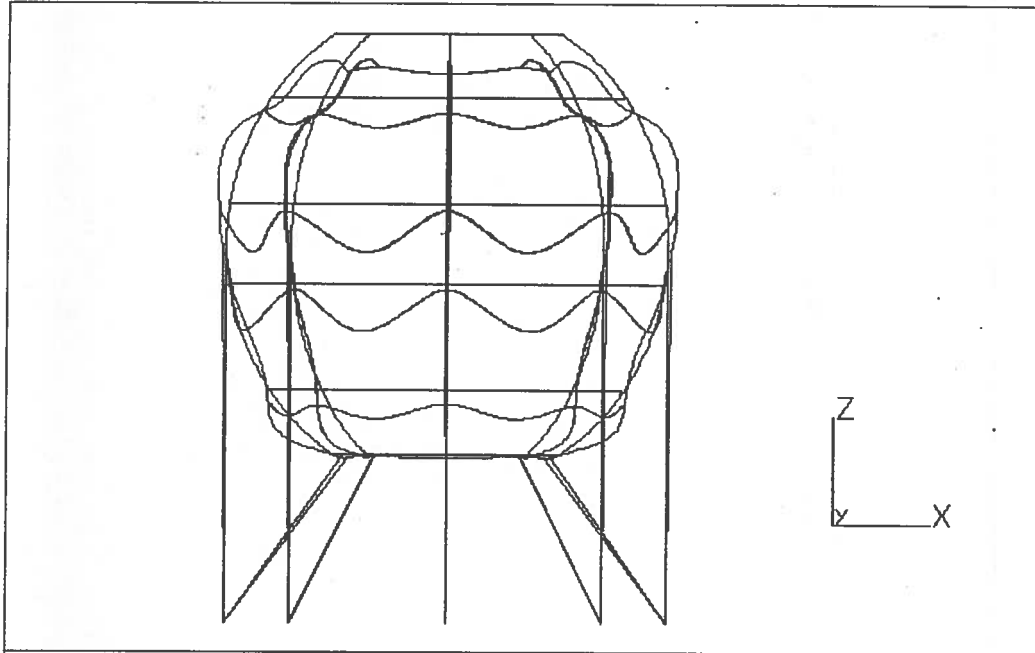

Fig. 4 — Deformation on the structure amplified 2000 times. FRONT VIEW.

The maximum rotation is on the second ring starting from the bottom, this value is 0.1199° , the ϕ polar angles that locate this maximum rotation are: 68° , 112° , 248° , 292° . This rotation is much less than 1° that is the constraint for rotation. There are not problems about mechanical stresses in the tubes of the structure.

In fact using as stress indicator the sigma so defined:

$$\sigma = |P/A| + |M_x/S_x| + |M_y/S_y|,$$

where P is axial load, M2 and M3 flexural moments in the two perpendicular directions lying on the bar section. The maximum σ we get is 2.25 Kg/mm^2 located at the intersection of meridians with the rings with the greatest diameter. This value is under the value of 17 Kg/mm^2 well which is the yield strength of steel.

In the above definition of the stress there isn't the stress component due to torsion moment, this component, which is a τ , can be calculated with the Bredt formula which gives: $\tau = 0.581 \text{ Kg/mm}^2$.

5. CLEANING PROCEDURE

This structure has to be installed inside an ultrapure detector so the material (stainless steel) must be pure in terms of bulk radiopurity and contamination free.

These two items are not correlated. In fact the content of uranium and thorium naturally present in the bulk is responsible of the intrinsic radioactivity while the contamination is due by the deposition of dust during the handling.

The intrinsic activity from the Uranium and Thorium chains produces alpha, beta and gamma but only the gamma's escape from the steel while the rest will be confined into the barrel. So the only way to reduce the intrinsic radioactivity is to choose a pure stainless steel (10^{-9} g/g U/Th).

For what concern the contamination the problem is quite different. If the steel is espoused to the air, as it is for a long time, dust and Radon daughters deposit on the steel surface. This deposit could be easily removed by wiping or other standard procedure but while the radon daughters are lying on the surface the alpha emitters (ex Po) decay and the daughter nuclide will be implanted in the material for several microns and this nuclide could leach out the surface after a long time.

In our detector these nuclides go directly into the water of the tank and they could migrate very close to the inner vessel.

To avoid this possibility we electropolished all the bars of the structure and, at the same time, we packed them into sealed bags. The electropolishing takes away ~ 20 μm of material in order to be sure to remove all the implanted nuclides.

REFERENCES

Borexino at Gran Sasso — Proposal for real time detector for low energy solar neutrinos,
Edited by: G. Bellini, M Campanella, D. Giugni, Dept. of Physics of the University
of Milano, I.N.F.N. — Milano, via Celoria, 16—20133 Milano, Italy

R. Raghavan , AT&T Bell , Murray Hill, USA