

INFN/TC-92/04
9 Marzo 1992

E. Cosulich, F. Gatti:

**A DIGITAL PROCESSOR FOR NUCLEAR SPECTROSCOPY WITH
CRYOGENIC DETECTORS**

INFN – Istituto Nazionale di Fisica Nucleare
Sezione di Genova

INFN/TC-92/04
9 Marzo 1992

A DIGITAL PROCESSOR FOR NUCLEAR SPECTROSCOPY WITH CRYOGENIC DETECTORS

E.Cosulich and F.Gatti

INFN-Sezione di Genova, via Dodecaneso 33, 16146 Genova

ABSTRACT

A description is given of a digital signal processing system designed for nuclear spectroscopy studies with low temperature particle detectors. The results of test experiments both with μ -calorimeters and with a traditional X-ray germanium detector show the efficiency and the flexibility of the system. The energy resolution and the pileup rejection efficiency obtained by the digital method with the germanium detector are superior to the typical performance of analogic hardware. Spectra obtained digitally using a Rhenium cryogenic detector are shown.

1. INTRODUCTION

Digital signal processing presently is not widely used in nuclear spectroscopy ^(1,2). Among other reasons, analogical systems are probably preferred because of their simple and immediate facility of use, the long lasting experience and the large availability of excellent instruments of this kind.

Moreover, the digital method requires, for a high statistics spectrum, either the storing of a huge amount of data, or real time processing with a powerful special purpose processor.

Anyway, for development work, for special purposes and new applications, as in nuclear spectroscopy measurements carried out with the recent cryogenic detectors^(3,4,5), dedicated hardware is not available and digital technique provides very convenient tools.

The outstanding features of the cryodetectors, that is high energy resolution, low threshold and a very wide choice of solid material of which they can be constituted, render them very valuable and sometime almost uninc candidates for investigation as 2β -decay or dark matter searches, applications in which the counting rate is very slow.

In the case the power of a *PC* is adequate for transient acquisition and storing and their rather slow pulses are easily digitally processed.

When the counting rate exceeds 10 counts/sec, as required in high statistic experiments, a dedicated acquisition system with dedicated hardware would permit a more efficient data handling and some real time monitoring of the experiment.

In any case, off-line analysis allows to reject spurious pulse and pileup with better efficiency than analogical means and the intrinsic limits to energy resolution can be closely approached by applying digital filters tailored to the specific experimental conditions.

We present here some results that were obtained with the system realized in our laboratory for investigations on cryogenic detectors.

A test made with a conventional *X*-ray germanium detector shows that also with traditional devices digital signal processing techniques can give better results in energy resolution and pileup rejection than the analogical processing.

2. APPARATUS

The experiment was designed to take advantage of commercial available instruments capable of converting analog pulses into digital data allowing easier data analysis and storage.

A block scheme of the acquisition system is given in fig. 1.

In most experiments a 12 bit CAMAC waveform recorder (LeCroy Mod. 6810) has been used to digitize the analog signal from the cryodetector.

A CAMAC (IEEE-583) to GPIB (IEEE488) interface (LeCroy Mod. 8901A) allowed us

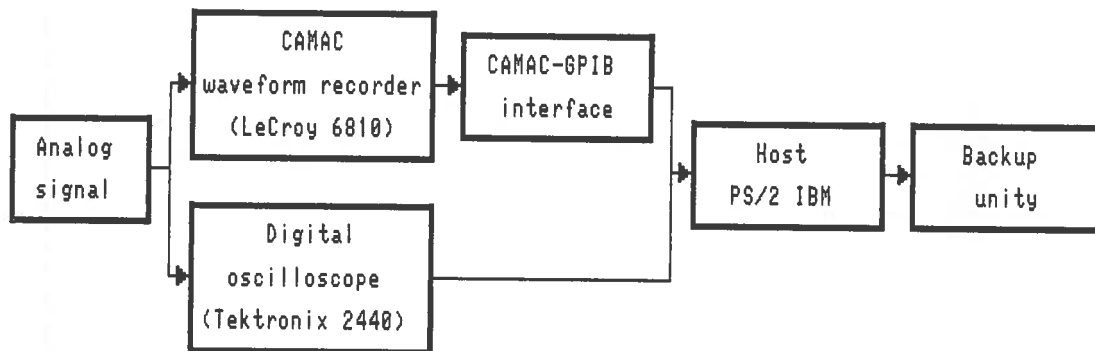

Figure 1: Block scheme of the acquisition system.

to transfer data and setup commands between the CAMAC device and a host personal computer (IBM PS/2 with a 120Mb HDD) for off-line analysis.

Also a 8 bit digital oscilloscope (Tektronix mod. 2440), connected via GPIB to the host computer, has been used to collect data. The scope permits to record data at higher sampling rate.

A standard GPIB bus controller (National MC-GPIB) has been installed in the host computer to manage the communications. Other similar digital devices may be used to capture single pulse waveforms.

The analog signal is digitalized by the CAMAC waveform recorder or by the digital oscilloscope. These instruments were set to record a file of 1024 12 bit (8 bit in the case of the oscilloscope) data words at every trigger with the trigger event at channel 256 and to transfer data to the host after each trigger event for off-line analysis. Posttriggering of the data is required by the analysis process in order to establish and correct the baseline dependence.

The required storage capability to the host computer is of 2Mb for 1024 events. This large amount of data may be transferred via ETHERNET to a VAX for backup on tape.

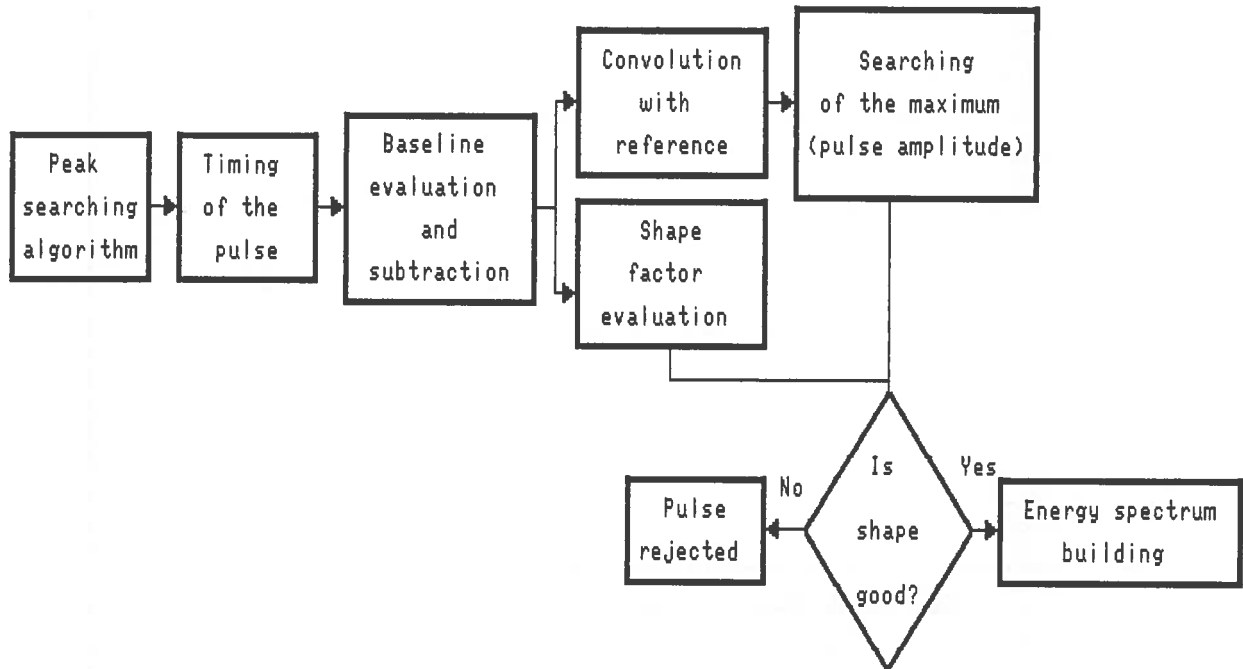

Figure 2: Simplified flow diagram of the analysis process.

The data acquisition code for both instruments was written with the help of the ASYST Scientific software package⁽⁶⁾. The driver library 6920-DL⁽⁷⁾ has been also used to interface to the CAMAC waveform recorder.

3. DIGITAL SIGNAL PROCESSING

In a typical run a series of digital processing algorithms processes the stored pulses as follows.

A peak searching algorithm is applied to each pulse to identify pulses pileup: the signal is first smoothed in order to reduce high frequency oscillations, then it is differentiated and the crossing of a threshold by the resultant signal is searched; a monotony criterium is imposed to the search. When there is only a peak in the registered waveform, or when the time interval between adjacent peaks is bigger then the pulse width, the energy of the pulse is evaluated, otherwise the pulse is rejected.

A center of gravity evaluation of the original pulse is used to extract the timing⁽⁸⁾ from

the original pulse.

Then the data of the prepulse region are used to establish a baseline⁽¹⁾ by assuming a constant function for the baseline dependence.

After the subtraction of the baseline, the pulse energy is determined by the convolution between the pulse and a reference pulse builded by mean of "good pulses" without pileup and noise spikes. The maximum of the product of convolution is assumed proportional to the pulse energy. This procedure emulates analog optimum filtering with the matched filter.

We have found that in convolving of arrays longer than 40 samples, FFT techniques are faster than the traditional convolution process.

For every pulse recorded a shape factor is evaluated in order to obtain a better energy resolution, rejecting spurious pulses, pulses with noise spikes superimposed and pileups not detected with the threshold crossing method.

The expression of the shape factor is the following:

$$m = \frac{\sum_i \left(\frac{s_i}{r_i} - \left\langle \frac{s_i}{r_i} \right\rangle \right)^2 r_i^2}{\sum_i s_i^2} \quad (1)$$

where r_i are the reference pulse samples and s_i are the measured pulse samples, $\langle \cdot \rangle$ is for mean value.

This factor is calculated after the baseline correction. It consists essentially in a weighted variance of the quotient between the signal samples and the reference pulse sample.

The shape factor m is independent from the pulse amplitude: two similar pulses with different amplitudes give the same value for m .

A good timing and baseline subtraction are essential for the correctness of pulse shape analysis.

The more m is near zero the more the pulse shape is good; plots of m versus the pulses energy permit us to select a band of acceptable values for m and then to improve the energy resolution.

Finally an energy spectrum is built with the pulses whose shape factor is good.

The analysis code, like the acquisition one, is written in the ASYST environment. Conversion of the analysis code into FORTRAN language to use the VAX CPU of our

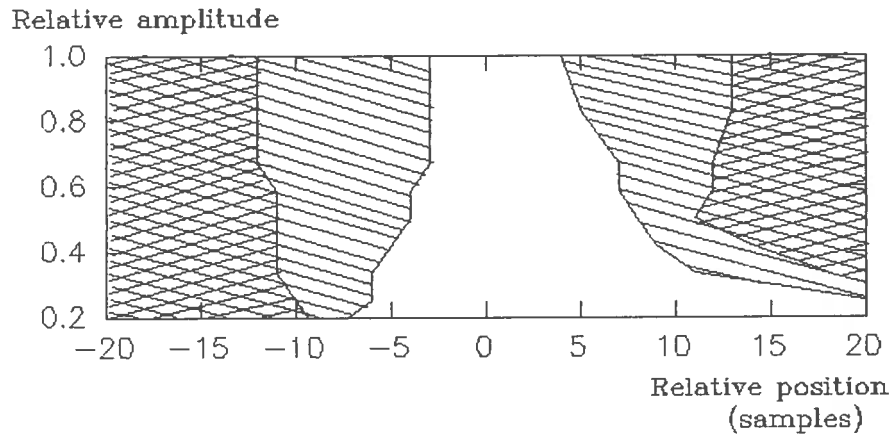

Figure 3: Relative effectiveness of double threshold crossing and shape analysis in pileup rejection. The zones filled by crossing lines contain the pileup cases discriminated by the shape factor and by the traditional level crossing pileup detection, in the zones filled by rising to left lines pileups are rejected only by shape factor analysis and the level crossing detection fails, the central white zone indicates that pileup is not discriminated by both methods.

department to improve its speed performances is in progress. On the host computer we used for analysis, every pulse is processed in a time varying between 1 and 2 s depending on the number of samples used for convolution.

A simplified flow diagram of the analysis process is given in fig. 2.

4. EXPERIMENTAL RESULTS

Pulse shape analysis is very useful in eliminating spurious pulses and is more efficient than the traditional edge detection technique in pileup rejection.

The relative effectiveness of the two methods in pileup rejection was evaluated by analysing a series of test pileup pulses built as follows: from a sample of low rate monochromatic α -particle registered pulses two typical waveforms were extracted.

The pulse width was contained in 128 samples. By software the second waveform was attenuated by a factor varying from 1 to 1/6 before and a delay with respect to the trigger ranging from -20 to $+20$ samples was applied. The two waveforms were then added.

The higher efficiency of pulse shape analysis is clearly indicated by the results shown in fig. 3. On the vertical axis we have reported the relative amplitude of the second waveform and on the horizontal its relative position in samples.

The two regions filled by crossing lines contains the pileup cases discriminated by the shape factor and by a traditional level crossing pileup detection, in the regions filled by rising to left lines pileups are rejected only by shape factor analysis and the level crossing detection fails, the central white zone indicates that pileup is not discriminated by both methods. The slight asymmetry with respect to the value 0 for relative position is due to the fact that it is more difficult to discriminate pileup in noise when an attenuated waveform follows a bigger one.

The energy resolution that can be achieved with the digital matched filter in practical cases approaches closely that of the ideal optimum filter and it is not inferior to that of the best analogical systems.

As an example, with digital signal processing, the $FWHM$ of the 59.95 keV γ -line of ^{241}Am from a Germanium detector results $\Delta E_{FWHM} = 420$ eV; analogically, with the same source and detector, we obtained at best $\Delta E_{FWHM} = 438$ eV using an Ortec Spectroscopy amplifier mod.673 *EG&G* with a five poles active filter. In the last case the expected signal to noise ratio is 88% of that of the optimum filter. The digital processor used an 8 bit *ADC* and 256 samples waveforms.

The choice of parameters for the matched filter is based on simple and straightforward considerations on the theory of digital processing as exposed in many standard textbooks⁽¹⁰⁾, indicating that the energy resolution improves slowly with the number of samples used N . However the computation time for the convolution increases with N faster than the limit to energy resolution and a compromise has to be found. We prefer usually to record signals of a detector under investigation at high sampling rate.

In order to keep N low, the reference and incoming waveform are framed to the time T during which the signal is well above noise. In this case, due to the short sampling period, a high cutoff frequency is allowed for the low-pass filter preceding the digitizer and the detailed time structure of the detector pulses can be recordered. This was found useful in investigating the physics of the pulse formation process and, moreover a high sampling rate minimize the effects of timing errors.

The energy spectrum of ^{241}Am obtained with a superconducting Rhenium bolometer⁽¹¹⁾ operating at 90 mK is shown in fig. 4. In fig. 4a the spectrum is recorded by a multichannel analyzer after shaping with a *RC-RC* filter amplifier. In fig. 4b the signals are digitally

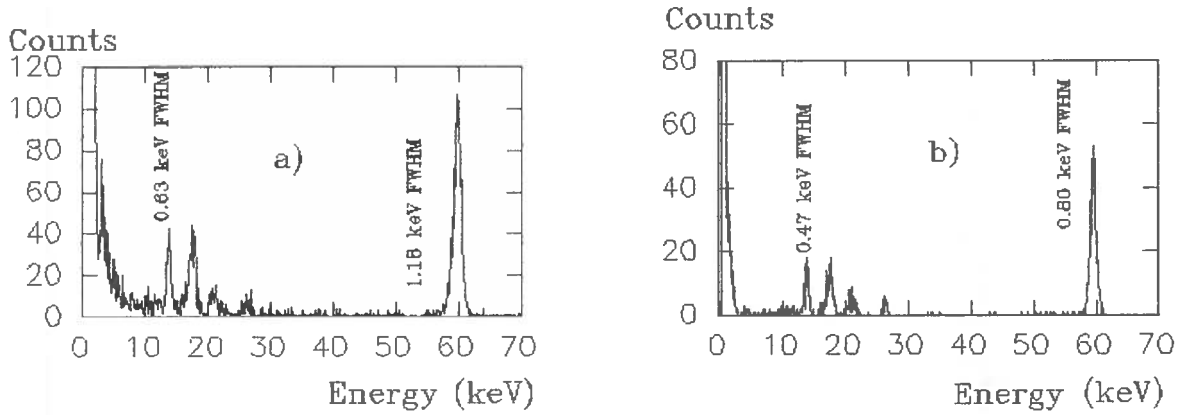

Figure 4: Energy spectrum of ^{241}Am obtained with a superconducting Rhenium bolometer operating at 90 mK.

(a): spectrum recorded by a multichannel analyzer

(b): spectrum recorded by the CAMAC device and digitally processed.

processed. The better resolution is evident in fig. 4b. The elimination of pileup between the peaks is due to pileup and spurious pulse rejection.

The efficiency of the digital technique appears clearly in fig. 5 where a preliminary β -spectrum of ^{187}Re is shown. This measure is preliminary to an experiment aiming at finding an upper bound for neutrino mass.

In fig. 5a the β -spectrum before shape analysis is plotted. In fig. 5b the filled circles indicate spectrum corrected by shape factor analysis, the empty triangles indicate the distribution of pileups and spurious pulses rejected by shape analysis and the solid line indicates the expected pileup distribution. The threshold effect at energies near 1 keV is due to the triggering level.

The distribution of the shape factors for the pulses of fig. 5a is reported in fig. 6. Pulses with shape factor less than 0.1 are retained good and correspond to the filled circles in fig. 5b, while pulses with shape factor greater than 0.1 are rejected and correspond to the empty triangles in fig. 5b.

5. CONCLUSIONS

A digital alternative to conventional pulse height analysis was described.

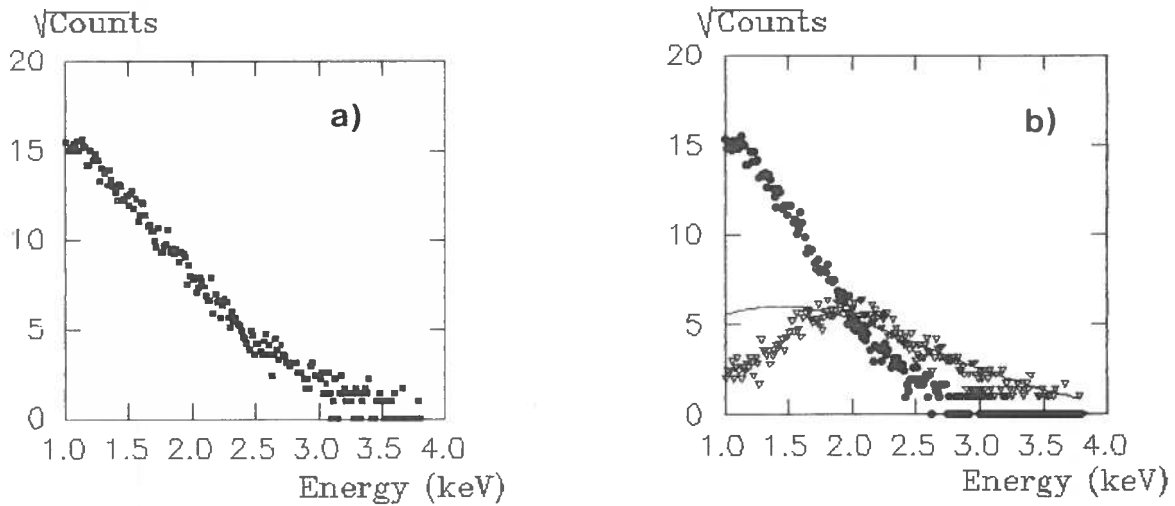

Figure 5: Preliminary β -spectrum of ^{187}Re . (a): β -spectrum before shape analysis. (b): spectrum corrected by shape factor analysis (filled circles), distribution of pileups and spurious pulses rejected by shape analysis (empty triangles) and expected pileup distribution (solid line).

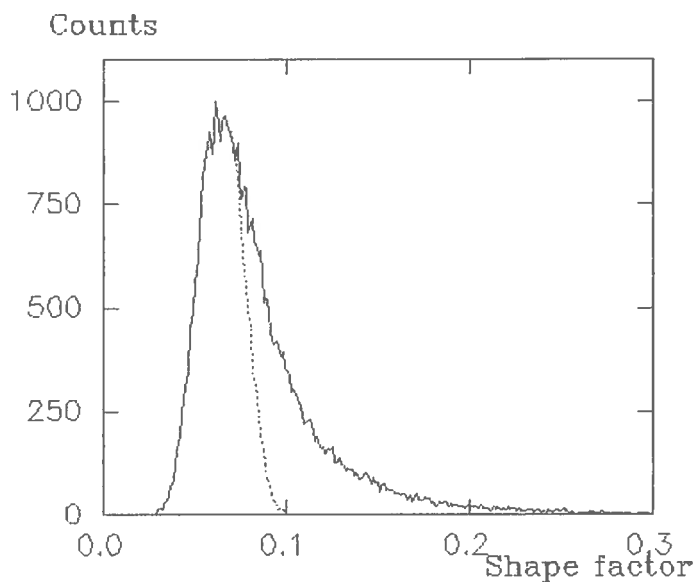

Figure 6: Distribution of shape factors for the pulses in fig. 5a.

The method was tested with off-line analysis of experimental data and it was found that pulse shape analysis permits to obtain good results both in pileup rejection and in spurious pulses discrimination.

Limiting factors of our system are low counting rate, huge storage and quite a long time of analysis.

A dedicated hardware would permit to make on-line analysis and to process every pulse just after its recording.

We plan to use this digital method for next measures together with a conventional multichannel for monitoring purposes.

ACKNOWLEDGMENTS

The authors wish to thank very warmly Prof. S.Vitale for his invaluable inputs, helpful discussions and suggestions to this work and for his critical reading of the manuscript.

REFERENCES

- (1) R.E. Chrien and R.J.Sutter Nucl. Instr. and Meth. A249(1986)421-425.
- (2) V. Drndarevic, P. Ryge and T. Gozani Nucl. Instr. and Meth. A277(1989)532-536.
- (3) N.E. Booth et al. "Cryogenic Detectors for Experiments in Elementary Particle Physics" to be published on Nucl. Instr. and Meth.
- (4) E. Fiorini and T.O. Niinikoski Nucl. Instr. and Meth. A224(1984)83-88.
- (5) A. Alessandrello et al. Nucl. Instr. and Meth. A289(1990)504-511.
- (6) "Asyst 3.1 A Scientific System", Asyst Software technologies. Inc. (1989).
- (7) "Le Croy Model 6920-DL Digitizer Driver Library", LeCroy Corporation, April 1990.
- (8) W. Farr et al. IEEE Trans. Nucl. Sci. NS-30(1983)95-97.

- (9) D.Schaile et al. Nucl. Instr. and Meth. A242(1986)247-253.
- (10) A.V. Oppenheim and R.W.Schafer "Digital Signal Processing" Prentice Hall Inc. Englewoodcity N.Y. (1975).
- (11) G.Gallinaro, F.Gatti and S.Vitale Europhysics. Lett., 14 (3) pp. 225-230 (1991).