

INFN/TC-01/11
9 Luglio 2001

**LOW CONSUMPTION CHARGE AMPLIFIERS FOR THE TIME OF FLIGHT
DETECTOR OF THE PAMELA EXPERIMENT**

P. Di Meo, M. Di Pietro, P. Parascandolo

INFN Sezione di Napoli, Complesso Universitario Monte S. Angelo, 80126 Napoli, Italy

Abstract

An important requirement for the Time of Flight (TOF) electronics of the PAMELA satellite detector is the low power consumption. We have designed two possible charge amplifiers which provide accurate measurements while keeping power absorption suitably low.

1. Introduction

The PAMELA telescope [1] will be installed on board of the Resurs-dk1 satellite, for which the launch is foreseen in 2002. The satellite will fly for at least three years with a 70 degrees orbit at about 700 km altitude. The main goals of the PAMELA experiment are the measurements of the antiproton and positron fluxes in cosmic rays, with high statistics in an energy range from 0.1 to 150 GeV, and the search for antinuclei up to 30 GeV/n. The telescope consists of a magnetic spectrometer, a TRD detector, an imaging calorimeter and a Time of Flight (TOF) system.

The electronics described here is part of the TOF readout. The information which the TOF must provide is direction, electric charge and speed of the incident particles. This requires the TOF system to have a flight-time resolution of about 100 ps and a wide dynamic range, as well as a limited power consumption.

The photomultipliers which readout the plastic scintillators of the TOF provide an anode signal proportional to the energy loss of the particles crossing the detector.

The charge integrators collect these currents and provide an output signal proportional to the total current. Consequently, the rise time of the signal at the output of the charge integrators is proportional to the duration of the current flow at the anode. The decay-time of the signal at the output of the charge integrator is related to the exponential discharge time constant of the circuit itself.

The signals coming from the TOF scintillators have a typical duration of about 10 ns. The energy conversion factor W ranges from 3 to 30 keV per electron. Therefore, we expect signal pulse heights which may vary from 50 mV to 5 Volt, whenever the anode current is closed onto a 50 Ohm impedance.

Commonly used nuclear pulse amplifiers have a configuration as outlined in Fig.1, where A denotes an inverting amplifier.

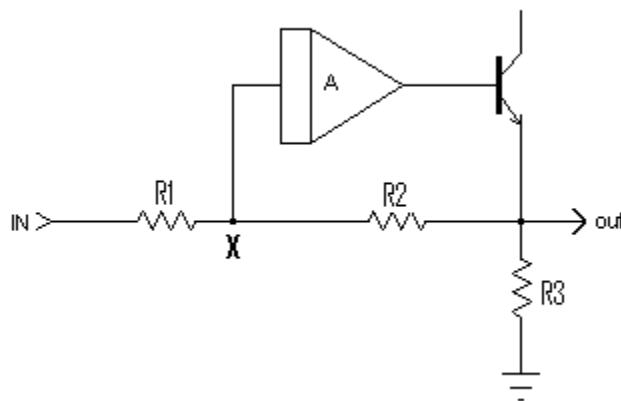

Fig. 1 – A typical amplifier.

If the magnitude $|A|$ of the amplifier's gain is much greater than unity then the signal at the input of the amplifier (point X) is much lower both of the V_{out} and of the V_{in} signal. By applying a current, at the input is developed a voltage $i \cdot R_1$. On the opposite, if a voltage V_{in} is applied then a current $i = (V_{in} / R_1)$ flows into the input. Should a voltage generator be applied at the input, the output signal will have a magnitude of $V_{in} (R_2 / R_1)$. If a current generator is applied the signal at the output will have a magnitude of $(V_{in} / R_1) R_2$ so that the amplifier behaves such as a current to voltage converter.

Feedback is taken onto the emitter terminal. In this way, the temperature dependent β of the transistor is stabilised by feedback and is virtually eliminated. By taking the output at the collector, instead, the β value must be taken into account. For a typical transistor with a $\beta=100$ and $\Delta\beta/\beta = (1\%)/^\circ\text{C}$ the output would change by a factor $(1 - 1/\beta) = (0.01\%)/^\circ\text{C}$.

2. A first configuration

Based on the configuration shown in Fig. 1, a charge sensitive amplifier can be designed by inserting a suitable capacitor in the feedback path (Fig. 2). With this configuration, both charge and current feedback are employed. The input transistor Q_1 sits normally at $2 V_{be}$ and acts as a low impedance source to Q_2 which provides for voltage gain. The transistor Q_3 provides a low impedance output.

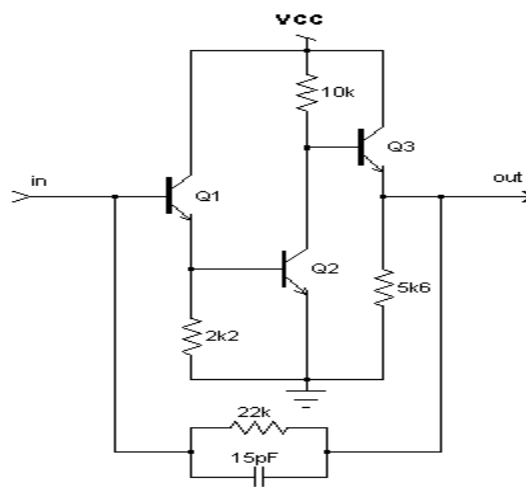

Fig. 2 – Transistor charge amplifier.

A monolithic transistor array such as the CA3127 [2] manufactured by Intersil suits particularly well for this application as each of the five transistors of the array has a value of f_T in excess of 1 GHz and low $1/f$ noise. Further, all transistors are at the same temperature.

Fig. 3a shows the 15ns rectangular negative pulse obtained from an HP8131A 500 MHz pulse generator used as a typical input. Fig. 3b shows the corresponding output pulse.

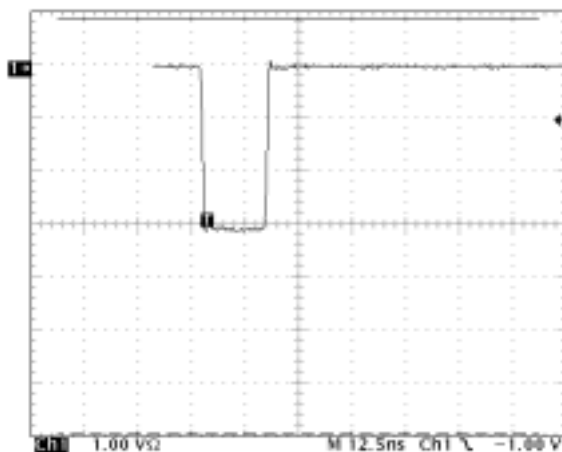

Fig.3a – Input pulse.

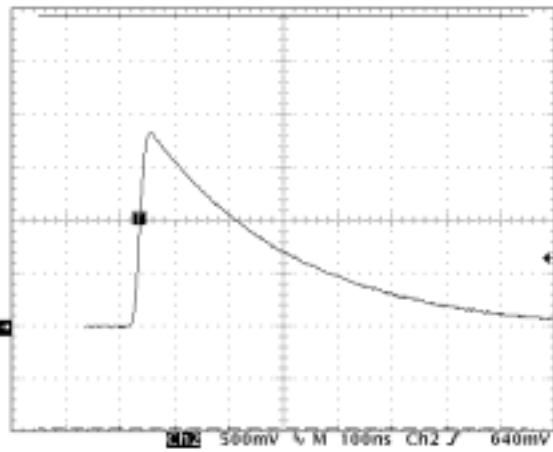

Fig.3b – Output pulse.

Fig 3c shows the measured performance of a prototype fed by a 15 ns pulse of variable amplitude. Fig 3d presents the transfer function obtained from an input pulse with constant amplitude (100 mV) but variable width.

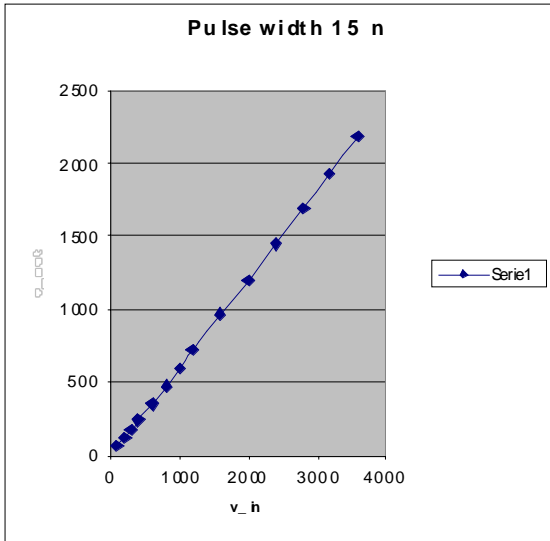

Fig. 3c – Gain at constant width.

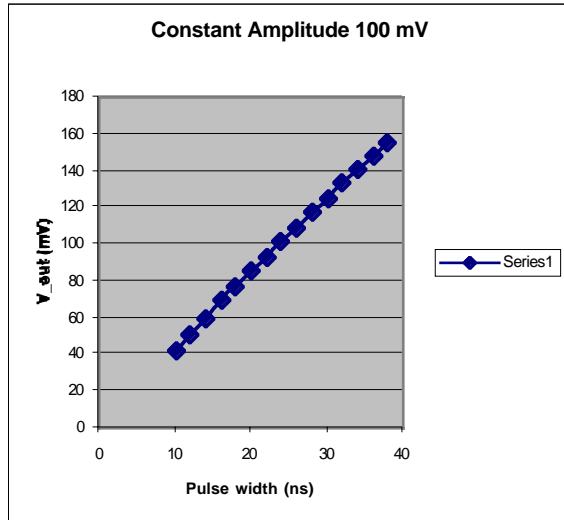

Fig. 3d – Gain at constant amplitude.

With the components values of Fig. 2, the measured performances of the three stage inverting preamplifier show a gain of 61mV/pC and a dynamic range from 100fC to 50pC with a 2% linearity. Powered at 12V the quiescent current is 1.53mA.

3. Another configuration

Another convenient way to design a charge amplifier is to use a modern high slew rate operational amplifier as an integrator.

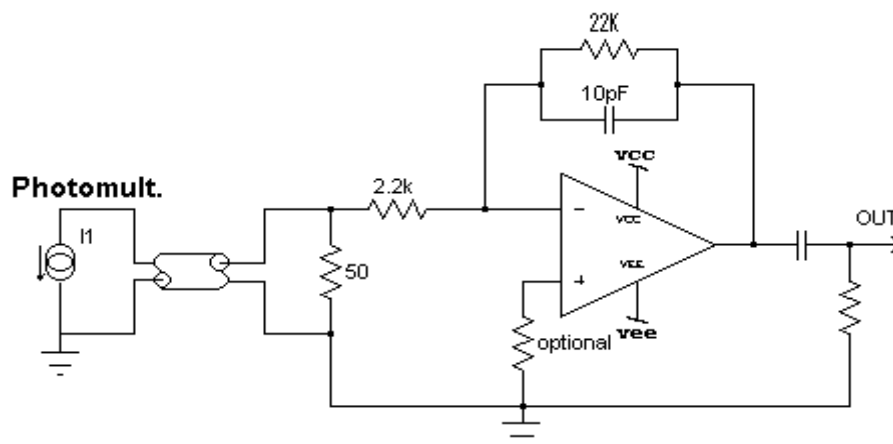

Fig. 4 – Op amp charge amplifier.

As the inverting input is a virtual ground, the input current flows through the capacitor. The voltage output is given by:

$$V_{in}/R = -C (dV_{out}/dt)$$

Therefore:

$$V_{out} = -1/RC \int V_{in} dt + K.$$

In order to be used for this application, the operational amplifier should have high input impedance, low input offset voltage, low bias current, stability with capacitive feedback and a very high slew rate as the input pulses have roughly a 10ns duration.

The resistor in parallel with the feedback capacitor in Fig. 4 sets the DC operating level by limiting the DC gain of the circuit, avoiding the saturation of the amplifier. The T network has been avoided, since has it would have required two additional components in the feedback loop. With the components shown the feedback resistor gives a discharge time constant of 200ns.

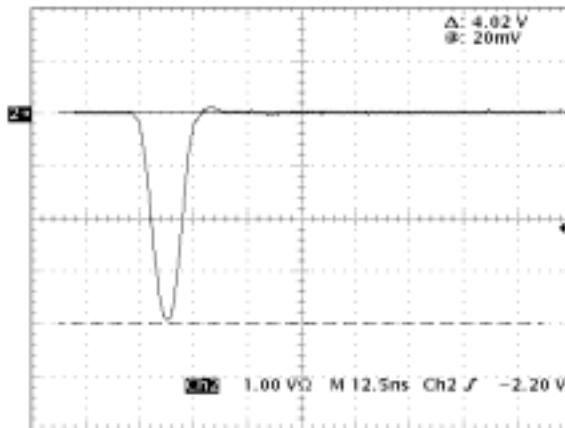

Fig. 5a – Input pulse.

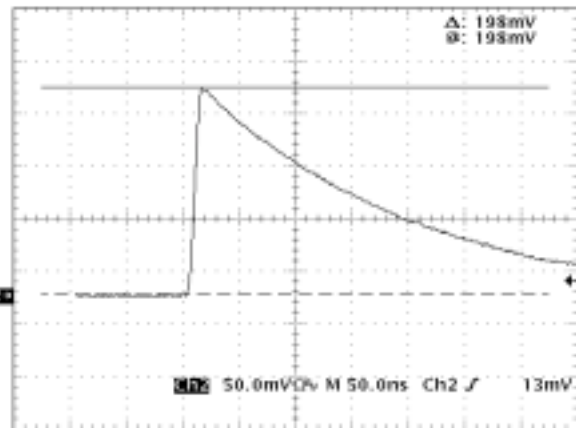

Fig.5b – Output pulse.

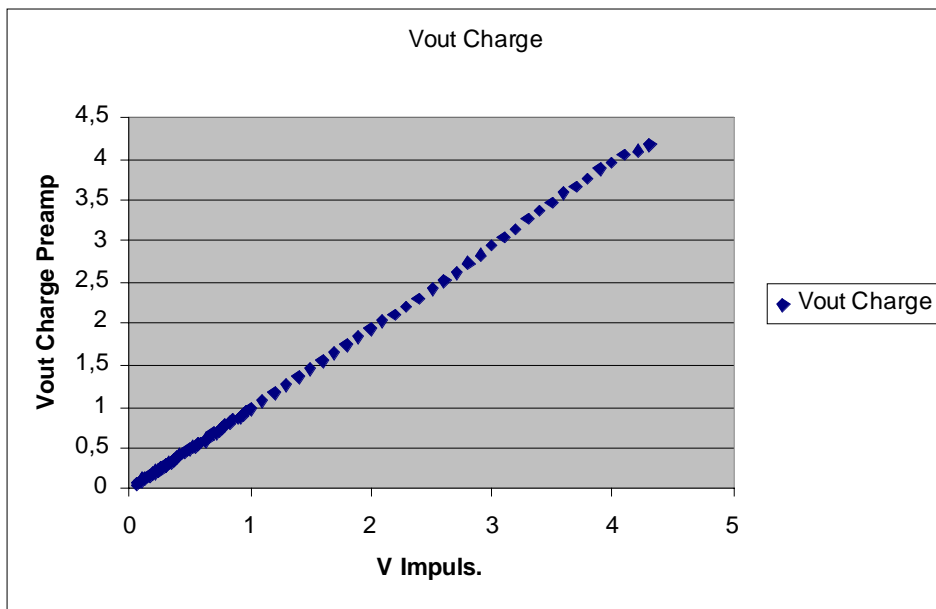

Fig. 5c – Measured transfer function.

For this application the DC bias at the output is of no concern as the output is AC coupled. This DC bias is due V_{os} (0.9mV typically) and to I_{bias} the bias current into (or out of) the inverting input terminal (0.2 μ A max.) and in the worst case is under 30mV. We have

chosen to fix the non inverting terminal at a good low impedance source (ground) to improve noise immunity.

With the components shown in Fig. 4, employing a 235 MHz low power voltage feedback amplifier the LM7121 manufactured by National [3] for the typical input of fig 5a we obtain the output pulse of fig 5b.

The measured transfer function of fig. 5c shows a preamplifier gain of 22mV/pC and a dynamic range from 100fC to 20pC with a linearity better of 2% when powered at $\pm 5V$. Quiescent current is 5mA.

Conclusions

Two different charge amplifiers have been designed and tested for the TOF detector of the PAMELA satellite experiment. The performance of the circuits are well within the experimental requirements.

References

- [1] O. Adriani et al., Proc. of the 26th IRCC, Salt Lake City, 1996.
- [2] Transistor Data Book, Intersil Corp.
- [3] Operational Amplifiers Data Book, National Semiconductor.