

ISTITUTO NAZIONALE DI FISICA NUCLEARE

Sezione di Trieste

INFN/BE-94/02

14 giugno 1994

G. Cantatore, F. Della Valle, E. Milotti, P. Pace, F. Perrone, E. Polacco, C. Rizzo,
G. Ruoso, E. Zavattini, G. Zavattini

FREQUENCY LOCKING OF A Nd:YAG LASER USING THE LASER ITSELF AS THE OPTICAL PHASE MODULATOR

Frequency locking of a Nd:YAG laser using the laser itself as the optical phase modulator

G. Cantatore, F. Della Valle, E. Milotti, P. Pace, E. Zavattini

Dip. di Fisica and INFN, via Valerio 2, 34127 Trieste, Italy

E. Polacco, F. Perrone

Dip. di Fisica, Piazza Torricelli 1, 56100 Pisa, Italy

INFN, via Livornese 582/a, 56010 S. Piero a Grado (PI), Italy

C. Rizzo, G. Zavattini

Laboratori INFN, Area di Ricerca, Padriciano 99, 34012 Trieste, Italy

G. Ruoso

Dip. di Fisica "Galileo Galilei", via Marzolo 8, 35131 Padova, Italy

INFN, Lab. Naz. Legnaro, via Romea 4, 35020 Legnaro, Italy

Abstract

We report frequency locking of a Nd:YAG tunable laser to a 2000 finesse 87 cm long Fabry-Pérot cavity in air using the Pound-Drever technique. The novelty is that the necessary phase modulation of the beam is obtained using the laser directly instead of an external phase modulator (Pockels Cell). The spurious relative amplitude modulation using this method was $\sim 3 \cdot 10^{-5}$ with a modulation index $\beta \sim 1$ and the spectral density of the frequency difference between the laser and the cavity is below $1 \text{ mHz} / \sqrt{\text{Hz}}$ in the region 1 Hz - 500 Hz.

I. Introduction

Laser frequency stabilisation has become an important issue playing a fundamental role in several applications. Requests come for example from QED tests,¹ gravitational wave detection with interferometers² and from metrology. A high-finesse Fabry-Pérot (F.P.) cavity is usually used as a frequency reference to which the laser is locked. The Pound-Drever technique^{3,4} is the one most commonly used for locking a laser to a cavity.

We report here frequency locking of a Nd:YAG NPRO laser to a 2000-finesse 87 cm long cavity in air. The novelty in our system is in producing the required phase modulation directly with the laser head itself thus eliminating the external phase modulator (Pockels cell). Therefore both the correction and phase modulation signals are fed onto the same actuator. With this technique we obtained a spurious relative modulation (RAM) of the beam intensity of $\sim 3 \cdot 10^{-5}$ with a modulation index $\beta \sim 1$ at the modulation frequency of 717.7 kHz. The relative frequency noise measured at the error point (see Figure 1) was below $1 \text{ mHz}/\sqrt{\text{Hz}}$ in the frequency region 1 Hz-500 Hz, besides the spurious peaks due to the mains (see Figure 2).

II. Method

The NPRO (Non Planar Ring Oscillator) laser (Lightwave Inc., model 124)⁵ is a tunable laser emitting at $\lambda = 1064 \text{ nm}$. Tunability is achieved by changing the geometry of the NPRO crystal. This is done either by means of a piezo-electric transducer (bandwidth = 100 kHz; dynamic range = 200 MHz) or by varying the temperature of the crystal (bandwidth = 1 Hz; dynamic range = 30 GHz). Pound-Drever locking also requires phase modulation of the laser beam. This is usually obtained by placing an EO crystal (Pockels Cell) in the light path. This method requires very good and stable alignment of the Pockels Cell to reduce Residual Amplitude Modulation (RAM) of the beam.

By definition the phase $\varphi(t)$ of the electromagnetic wave is the time integral of the angular frequency

$$\varphi(t) - \varphi(t_0) = \int_{t_0}^t \omega(t) dt \quad (1)$$

If we modulate the frequency of the laser then

$$\omega(t) = \omega_0 + A \cos(\Omega_m t + \phi) \quad (2)$$

where Ω_m is the angular frequency of the modulation. Therefore

$$\varphi(t) = \int_0^t [\omega_0 + A \cos(\Omega_m t + \phi)] dt = \omega_0 t + \beta \sin(\Omega_m t + \phi) \quad (3)$$

where we have introduced the index of modulation $\beta = A/\Omega_m$. Frequency modulation is therefore equivalent to phase modulation. This allows the possibility of using the laser itself as the optical phase modulator. Below we are going to describe a set-up in which we have realized phase modulation acting directly on the laser's radiation angular frequency and therefore using the laser itself as the optical phase modulator. The actuator is then used simultaneously for phase modulation and feedback.

III. Apparatus

A scheme of our set-up is shown in Figure 1.

The feedback signal is summed to the phase modulation signal which is then fed to the laser.

The laser emits a 50 mW light beam mode matched to the TEM₀₀ mode of a Fabry-Pérot cavity by means of the telescope. The 87 cm long cavity is in air and has a measured finesse of $\mathcal{F} = 2000$. The mirrors are high reflectivity dielectric multilayer (LASEROPTIK GmbH.) mirrors each with a measured transmittivity of $\tau = 3.8 \cdot 10^{-4}$. The cavity transmission was measured to be 4.3%.

The servo amplifier is a 4-stage integrator with a unity gain point of 60 kHz. The slope of 24 db/oct begins below 7 kHz and the transfer function has 3 poles in the origin and one at 0.16 Hz.

IV. Choice of Ω_m

To obtain best locking one must employ the widest bandwidth in the feedback signal to be fed to the actuator. For this it is necessary that Ω_m be

larger than the bandwidth of the actuator chosen to be where the behaviour of the crystal is linear (BW = 100 kHz). In this region the response of our laser is 5 MHz/Volt on the piezo-electric actuator.

For modulation frequencies greater than 100 kHz the response of the crystal is no longer linear but can still be used at fixed frequencies for phase modulation.

The criterion used to choose Ω_m was to minimize the RAM for a given index of modulation β . In fact, as can be seen in Figure 3, for certain frequencies the RAM has local minima. At these frequencies the ratio of RAM/ β was minimum with a RAM of $\sim 3 \cdot 10^{-5}$. In addition the ratio RAM/ β results to be constant as a function of the voltage applied to the piezo electric transducer. Typically the 2π voltage is 0.5 Volts.

In table 1 are shown β and RAM versus the applied peak to peak voltage for several frequencies. The frequencies marked with an asterisk correspond to local minima.

During months of operation we observed no variations in the behaviour of the crystal as regards to the frequencies for the local minima and the response of the laser.

The frequency at which we decided to work was $\Omega_m = 717.7$ kHz.

V. Results

Figure 2 shows our results for the spectral density of the difference between the laser frequency and the F.P. cavity. In the frequency range 1-50 Hz we have achieved a spectral density below $1 \text{ mHz}/\sqrt{\text{Hz}}$. In the 50 - 500 Hz range large peaks appear due to the mains frequency and its harmonics. The base of the peaks, however, is also below $1 \text{ mHz}/\sqrt{\text{Hz}}$.

VI. Conclusions

It has been shown that it is possible to lock a laser to a cavity by the Pound-Drever technique without using the external phase modulator. Phase modulation of the beam was achieved by acting directly on the laser itself.

This has the advantage of simplifying the optical set-up without reducing the performance of the locking.

This work has been done within the PVLAS collaboration whose aim is to measure the vacuum magnetic birefringence as predicted by Quantum Electro-Dynamics.¹

7. Results

Figure 2 shows our results for the optical density of the different frequencies in the laser frequency and the 1.5 eV range. In the frequency range 1.50 to 1.51 eV we have observed a spectral density below 1 mW/cm². In the 1.50 to 1.51 eV range laser spots appear due to the noise spectrum and the background. The size of the noise, however, is also below 1 mW/cm².

7.1. Conclusions

It has been shown that it is possible to lock a laser that travels by the Pound-Drever-Hall setup without using the external signal reference. The modulation of the laser was achieved by acting directly on the laser itself.

Tables

ν (kHz)	V_{PP}/β (mV)	RAM/ V_{PP} (mV ⁻¹)	RAM/ β
537.6 *	109	$3.0 \cdot 10^{-7}$	$3.3 \cdot 10^{-5}$
600	161	$4.6 \cdot 10^{-7}$	$7.3 \cdot 10^{-5}$
630	61	$1.6 \cdot 10^{-6}$	$9.5 \cdot 10^{-5}$
717.7 *	62	$6.0 \cdot 10^{-7}$	$3.7 \cdot 10^{-5}$
870	79	$5.4 \cdot 10^{-6}$	$4.3 \cdot 10^{-4}$

TABLE I. RAM and β in function of the frequency and the voltage applied to the laser. The frequencies marked with an asterisk correspond to local minima in the RAM.

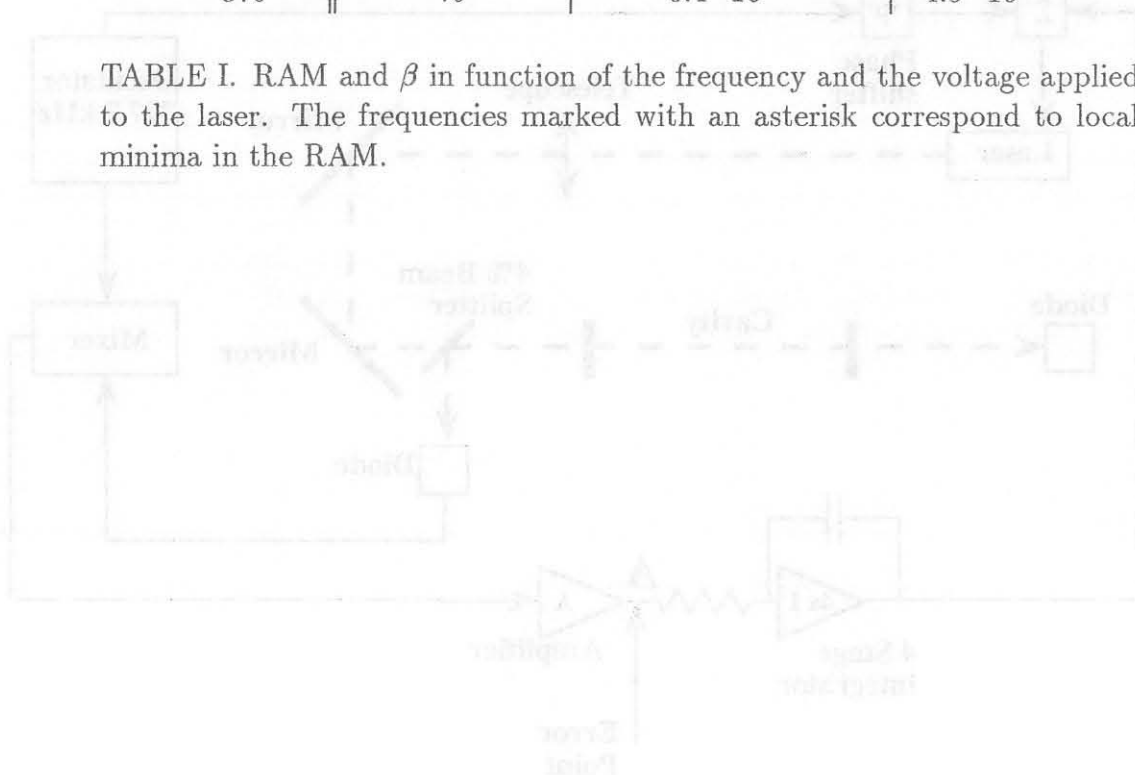

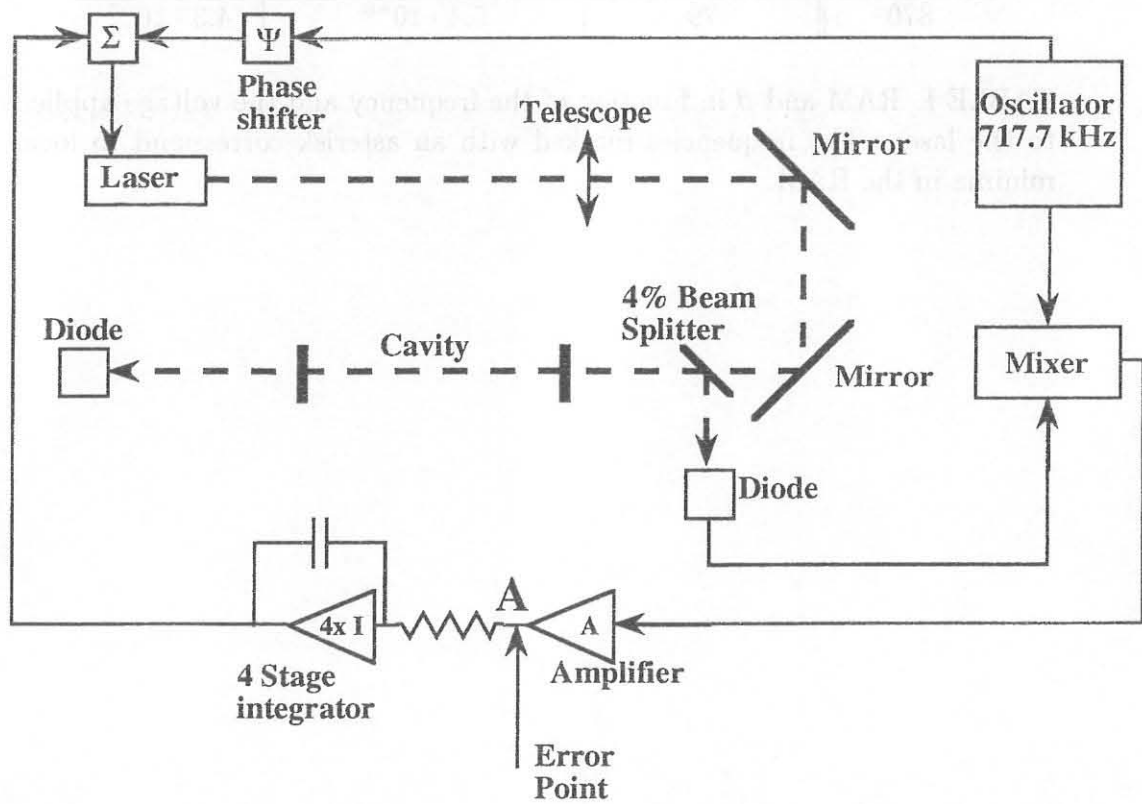

FIG. 1. Schematic drawing of the apparatus.

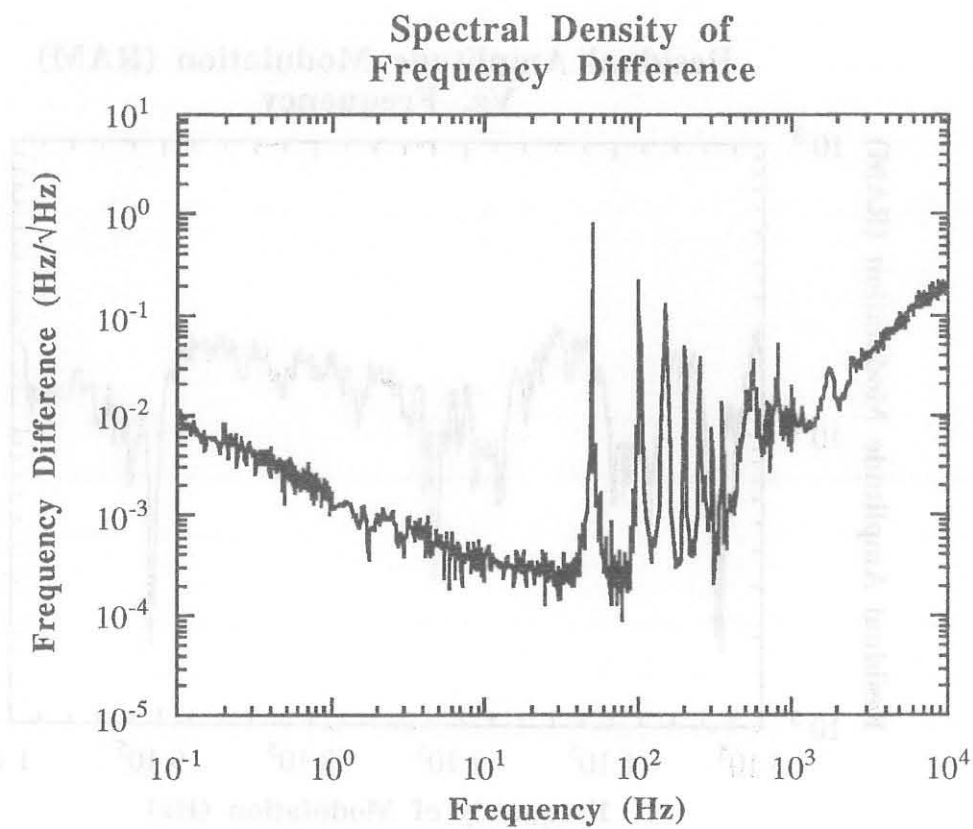

FIG. 2. Spectral density of the difference in frequency between the laser and the cavity. This is obtained by measuring the noise spectrum at the error point and multiplying it by the slope of the error signal in the same point. The large peaks are due to the 50 Hz and its harmonics.

Residual Amplitude Modulation (RAM) Vs. Frequency

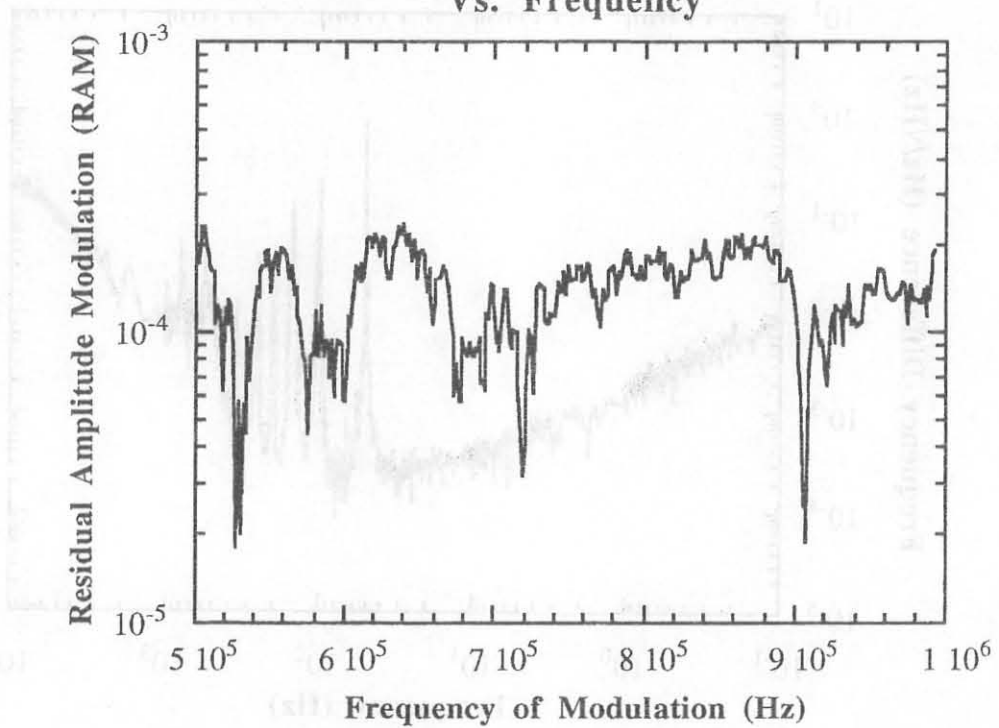

FIG. 3. Residual Amplitude Modulation (RAM) as a function of the frequency of modulation with the peak to peak voltage on the piezo of 50 mV.

References

- ¹D. Bakalov, G. Cantatore, G. Carugno, S. Carusotto, P. Favaron, F. Della Valle, I. Gabrielli, U. Gastaldi, E. Iacopini, P. Micossi, E. Milotti, R. Onofrio, R. Pengo, F. Perrone, G. Petrucci, E. Polacco, C. Rizzo, G. Ruoso, E. Zavattini, G. Zavattini
Nuclear Physics B (Proc. Suppl.) **35**, 180 (1994)
- ²J. Hough, H. Ward, G.A. Kerr, N.L. Mackenzie, B.J. Meers, G. P. Newton, D.J. Robertson, N.A. Robertson, and R. Schilling
The stabilisation of lasers for interferometric gravitational wave detectors, in *The Detection of Gravitational Radiation* ed. by E. G. Blair (Cambridge University Press, Cambridge, England, 1991)
- ³R. V. Pound, *Rev. Sci. Instruments* **17**, 490 (1946)
- ⁴R.W.P. Drever, J.L. Hall, F.V. Kowalsky, J. Hough, G.M. Ford, A.J. Munley and H. Ward *Appl. Phys.* **B31**, 97 (1983)
- ⁵A.C. Nilsson, E.K. Gustafson, R.L. Byer *Journal of Quantum Electronics* **25**, 767 (1989)