

ISTITUTO NAZIONALE DI FISICA NUCLEARE

Sezione di Bologna

INFN/BE-71/2
24 Marzo 1971

M. Bruno and G. Vannini: SPECIFIC ENERGY LOSS OF FISSION
FRAGMENTS AS A FUNCTION OF MASS: PRESENT STATUS OF
THE EXPERIMENT. -

M. Bruno and G. Vannini: SPECIFIC ENERGY LOSS OF FISSION FRAGMENTS AS A FUNCTION OF MASS: PRESENT STATUS OF THE EXPERIMENT. -

1. - INTRODUCTION. -

We describe here the present status of an experiment which has been performed within a Bologna University - EURATOM collaboration^(*), aiming to determine the specific energy loss of fission fragments of known mass in a gaseous mixture. The chief interest of such measurement is the possibility of a more detailed study of the influence of mass on the interaction of fission fragments with matter, especially referring to the charge exchange of the fragments along their path. In particular, the specific energy loss curves (i. e. (dE/dx) vs. x) also supply the effective charge of the associated fragments as a function of x and of fragment velocity⁽¹⁾.

The measurement of the specific energy loss has been only performed in the past for the light and heavy fission fragments emitted with the highest probability from a given fission source. The most relevant works on this line were carried out by Lassen⁽¹⁾ and more recently by Moore and Miller⁽²⁾. Using a ionization chamber technique, Lassen observed the energy loss of fission fragments from ^{235}U in a given gaseous thickness $\Delta x(x)$ for different gaseous paths x . Moore and Miller used instead two solid-state detectors to stop coincident fission fragments from a 4π - source of ^{235}U and to measure their residual energy after a variable gaseous path. Both the mentioned apparatus were only set-up to measure the energy loss of the most probable light (median light) and heavy (median heavy) fragments of the total mass distribution.

(*) - M. Forte (EURATOM - Ispra), and A. Bertin, M. Bruno, G. Vannini and A. Vitale (Bologna).

2.

The results given by these authors are shown in Fig. 1.

On the other hand, to determine the specific energy loss of fission fragments as a function of their mass it is necessary to detect simultaneously the specific energy losses and the total energy of both fragments, the latter parameter being necessary to extract out the masses. In the experiment we discuss here, ionization chamber and solid-state counters techniques are coupled to supply the required information in the case of ^{252}Cf .

Section 2 is devoted to discuss the experimental method. The preliminary measurements and the experiment are discussed in Section 3, whereas the used fission source is described in the Appendix.

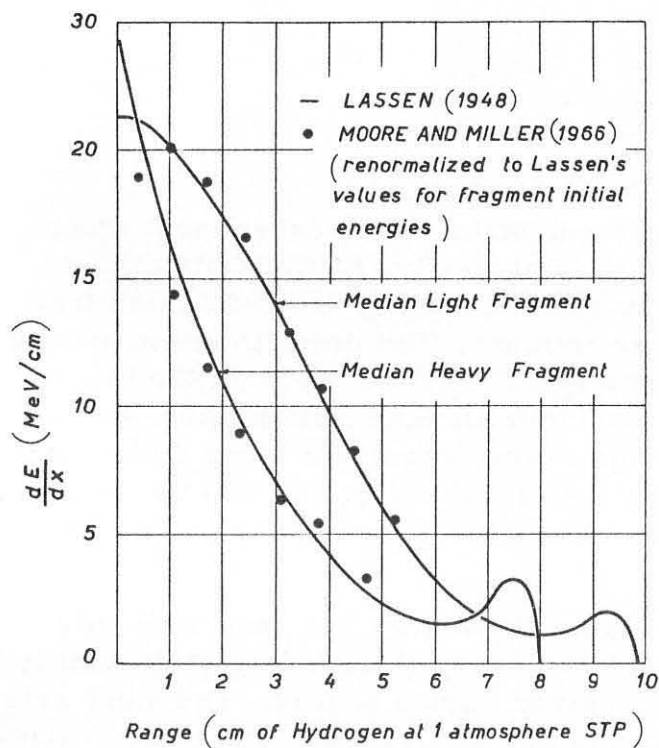

FIG. 1 - Rate of energy loss of median light and heavy fragments from ^{235}U fission along their range in Hydrogen. The solid curve is taken from the measurements made by Lassen (Ref. 2); the data points are the results given by Moore and Miller (Ref. 3), renormalized to the values given by Lassen for the initial fragment energies.

2. - THE METHOD AND THE EXPERIMENTAL APPARATUS. -

In the present experiment, the fission fragments emitted in opposite directions from a 4π -source of ^{252}Cf were slowed down in a fixed distance d of 5 cm of a gaseous mixture, before being stopped by two solid state detectors, which measured the residual energies of the fragments (R_1 and R_2 signals, see Fig. 2). A two-sections grid ionization chamber⁽³⁾ working with the gaseous mixture itself measured the energy loss of each fragment along the distance d (A_1 and A_2 signals). The measurements were repeated over an interval of pressures ranging from 2 to 20 cm Hg.

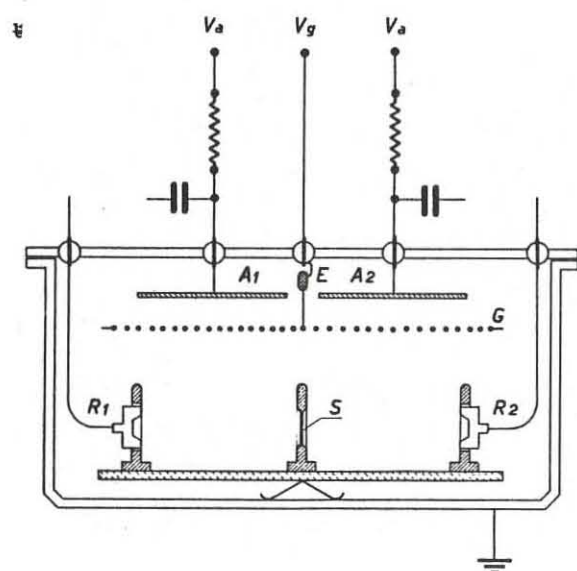

FIG. 2 - Simplified scheme of the apparatus used in the present experiment.

For each fission event, in this way, the following data could be obtained:

i) the total initial energy E_1 and E_2 of each fragment, since with proper normalizations one can state:

$$(1) \quad E_i = R_i + A_i ;$$

ii) the masses m_1 and m_2 of both fragments, from the equations^(x):

$$(2) \quad m_1 E_1 = m_2 E_2$$

$$(3) \quad m_1 + m_2 = m_t$$

m_t being the mass of the ^{252}Cf nucleus.

The specific energy loss for one fragment of a given mass will then be given by

$$(4) \quad \left(\frac{dE}{dx}\right)_x = (A_i(P + \Delta P) - A_i(P)) / \Delta x$$

(x) - Account of the neutron emission and of the energy loss by nuclear scattering will be taken by standard methods^(4, 5) during the analysis.

4.

where Δx is the difference in the gaseous paths corresponding to two different pressures P and $P + \Delta P$.

The chamber was filled with a standard mixture of Argon plus a few percent of Nitrogen and Buthane, in such a way to supply fast pulses and to reduce the effects of occasional contaminations⁽⁶⁾. The gas pressure could be measured with a precision of 0.5 mm Hg over a range of pressure from 1 to 800 mm Hg. The energy resolution of the ionization chamber for a 5 MeV alpha-source was found to be about 1%. The energy resolution of the (ionization chamber)+(solid state detector) system for the same alpha source and for gas pressures from 40 mm Hg to 300 mm Hg was also measured: the worst energy resolution obtained was about 1.6%.

A simplified diagram of the electronics is shown in Fig. 3.

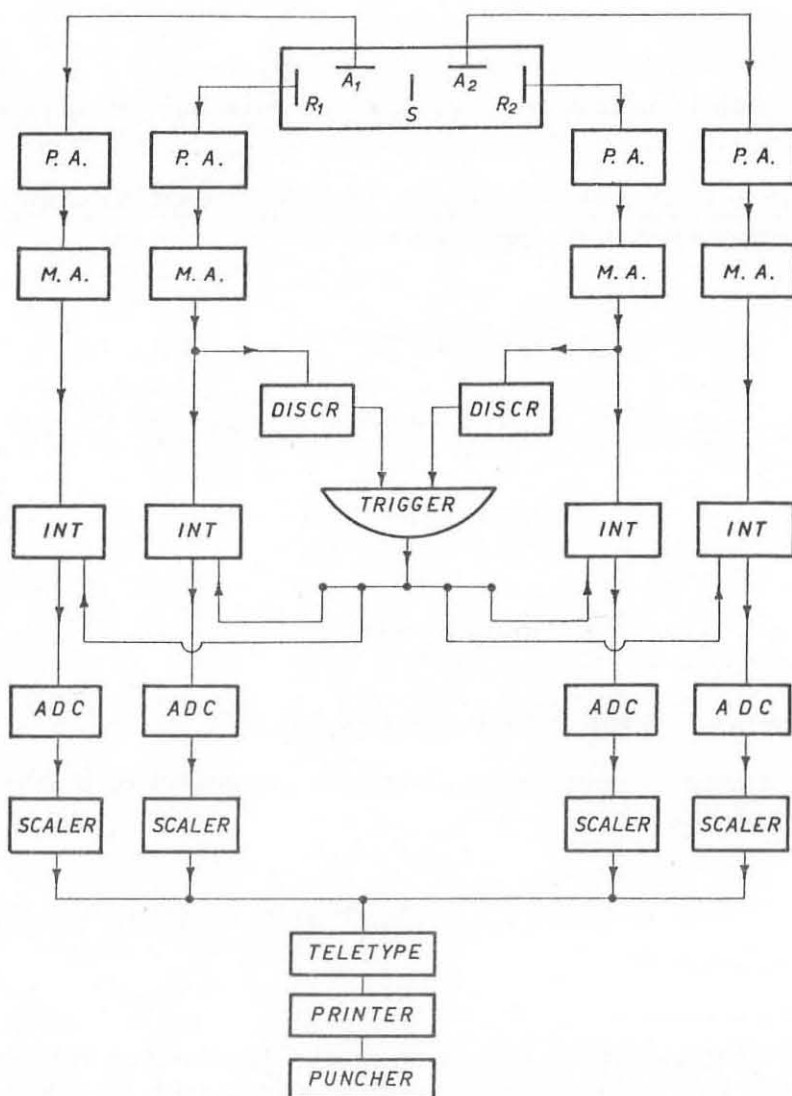

FIG. 3 - Block diagram of the electronics.

The main function of this circuitry was to describe one fission event by digitalizing the corresponding four signals R_1, R_2, A_1, A_2 . Such operation was performed as follows:

i) the pulses outcoming from the two-section ionization chamber and from the two solid-state detectors were separately amplified by standard electronics, and then sent to four 1000 channels analog-to-digital converters (ADC).

ii) the signals from the solid state detectors were separately sent to a coincidence circuit (TRIGGER coincidence), to supply a gating signal for the ADC circuits, in order to accept only those pulses due to one fission event. The threshold of the discriminators shown in Fig. 3 was adjusted in such a way to eliminate the signals corresponding to the 6.13 MeV alpha particles emitted by the ^{252}Cf source.

iii) the digitalized signals selected in this way were then sent to the SCALERS, and punched on paper tape. The TRIGGER coincidence started the data recording and supplied a proper paralysis signal to the SCALERS, in order to avoid pile-up of pulses while an event was being punched.

The data obtained in this way were then recorded on magnetic tapes for the final computer analysis. A first analysis is being devoted to examine the total spectra of the fragments, whereas in a second step the events will be analyzed in detail to extract out the masses and ionization energy losses of each fragment.

3. - THE EXPERIMENT. -

The measurements of the residual energy and of the energy loss for the fission fragments in the gaseous mixture were periodically repeated varying the gas pressure inside the ionization chamber by steps of 1 cm Hg in the range from 2 to 20 cm Hg. These limits were chosen taking into account the data by Lassen⁽¹⁾ on the range of median-heavy and median-light fission fragments from ^{235}U in Argon. For each pressure about 40,000 fission events have been recorded up to date. An approximate calculation shows that such statistics correspond to an error of about 2 mass units in the values of the determined masses.

To calculate the total energy of the fragments from the signals A_i, R_i , it has to be taken into account that they lost their energy into two different media (i. e. the gaseous mixture of the ionization chamber section and the silicon in the solid state detector). The energies required to release one pair of carriers in the used gas mixture and in the silicon detectors were about 28 eV⁽⁶⁾ and 3.5 eV respectively. A calibration by a pulse generator was then performed to adjust the amplification of the electronics chains to get an approximately equal energy response in

6.

the ionization chamber sections and in the solid state detectors. The linearity of the four electronics chains was also tested by artificial pulses, and no threshold was found (see for instance Fig. 4).

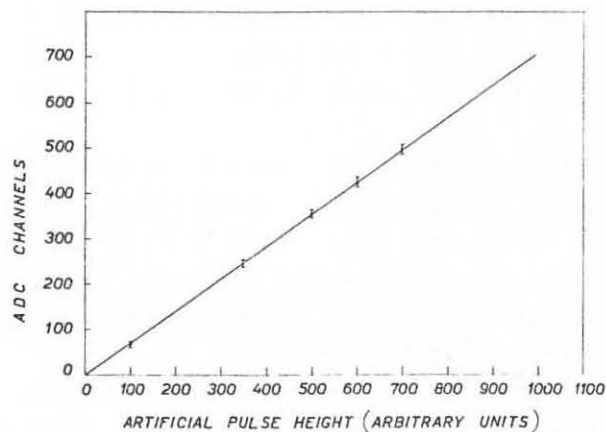

FIG. 4 - Typical response of the electronics to artificial pulses in the range corresponding to the conditions of present measurement. Similar results were obtained for the other channels (A_1 , A_2 and R_2 signals).

A more refined equalization of the energy response of the ionization chamber and of the solid state detectors was finally achieved as follows: before and after each measurement at a given pressure, the total energy distribution of the fission fragments was recorded under a vacuum of about 10^{-4} cm Hg (see Fig. 5), i. e. using only the solid state detectors; the total energy distributions recorded at any pressure, i. e. obtained by Equation (1), were then normalized to the ones obtained under vacuum. Fig. 6 shows a partial spectrum of the so-normalized energies of the fission fragments at a pressure of 4 cm Hg.

The stability of the apparatus was frequently checked by recording the spectra of the 6.13 MeV alpha-particles emitted by ^{252}Cf both in the ionization chamber section and in the solid state detector of one chain at a time.

The total energy of the fission fragments obtained by Equation (1) has to be corrected to take into account the energy loss due to nuclear scattering: this can be done using a standard formula by Schmitt et al.⁽⁵⁾.

As is well known, moreover, one fission event is closely followed by the emission of neutrons. Also from this standpoint, therefore, the energies obtained by Equation (1) and (2) can be considered only a first approximation of the actual ones. Taking account of the neutron emission, Equation (3) becomes

$$(5) \quad M_1 + M_2 + \nu_1 m_n + \nu_2 m_n = m_t$$

where m_n is the neutron mass, and M_1 and M_2 are the masses of the fragments after the emission of neutrons as calculated by Terrel⁽⁴⁾; ν_1 and

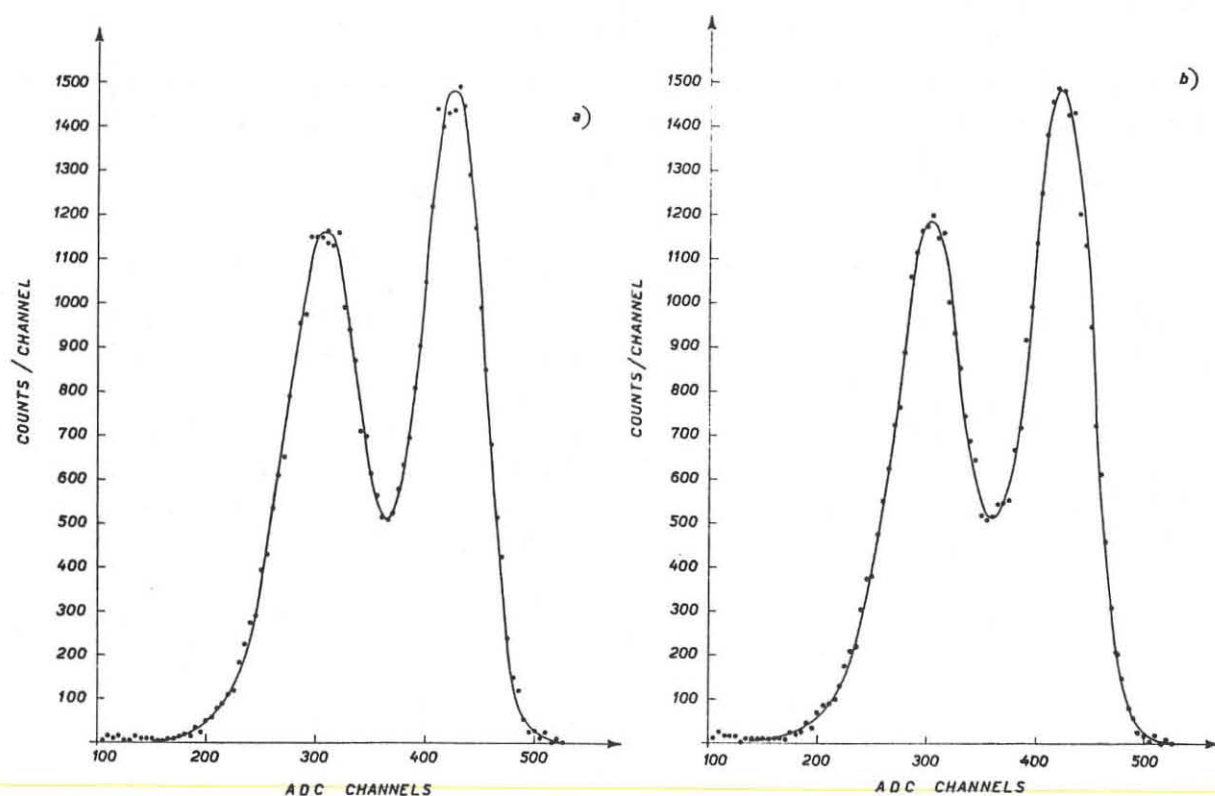

FIG. 5 - Energy spectra of fission fragments from ^{252}Cf recorded under vacuum condition by: a) R_1 detector; b) R_2 detector.

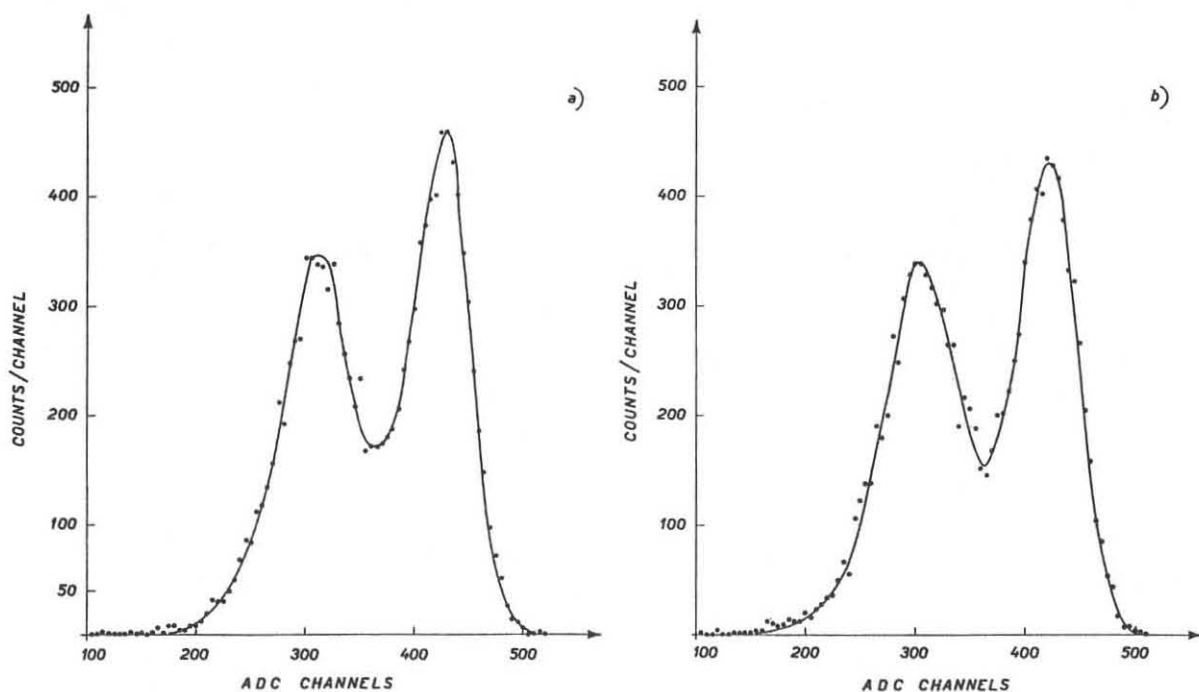

FIG. 6 - Total energy spectra of ^{252}Cf fission fragments obtained through Equation (1) from the data corresponding to a pressure of 4 cm Hg: a) $(A_1 + R_1)$ signals; b) $(A_2 + R_2)$ signals.

8.

ν_2 are the number of neutrons emitted with fragments 1 and 2 respectively. Since ν_1 and ν_2 are also function of the masses of fragments 1 and 2, an interative process of approximation will be used to calculate m_1 and m_2 .

The data analysis is proceeding with two successive aims:

i) to determine the specific energy loss of the median light and median heavy fragments for ^{252}Cf , in order to compare these results to the one by Lassen (see Fig. 1);

ii) to obtain the maximum number of curves describing the ionization energy loss of ^{252}Cf fission fragments having different masses. With the statistics of the present data, we hope to get such curves for a number of different masses of the order of ten.

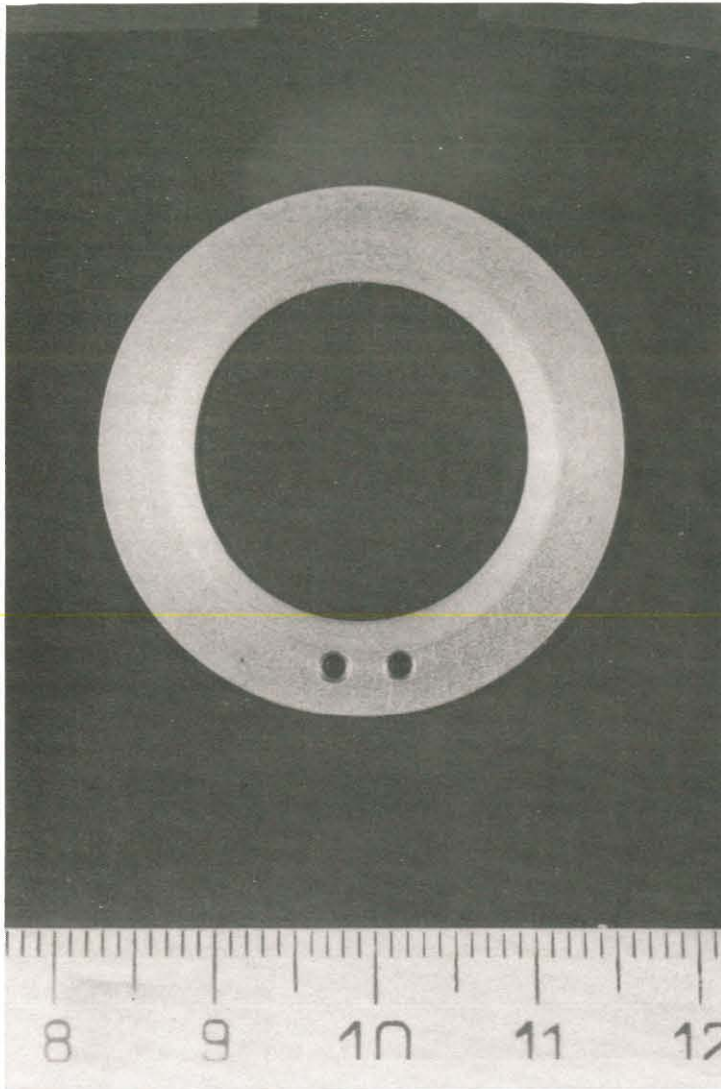

FIG. 7 - Aluminium ring used to hold the VYNS layer in the prepared ^{252}Cf source.

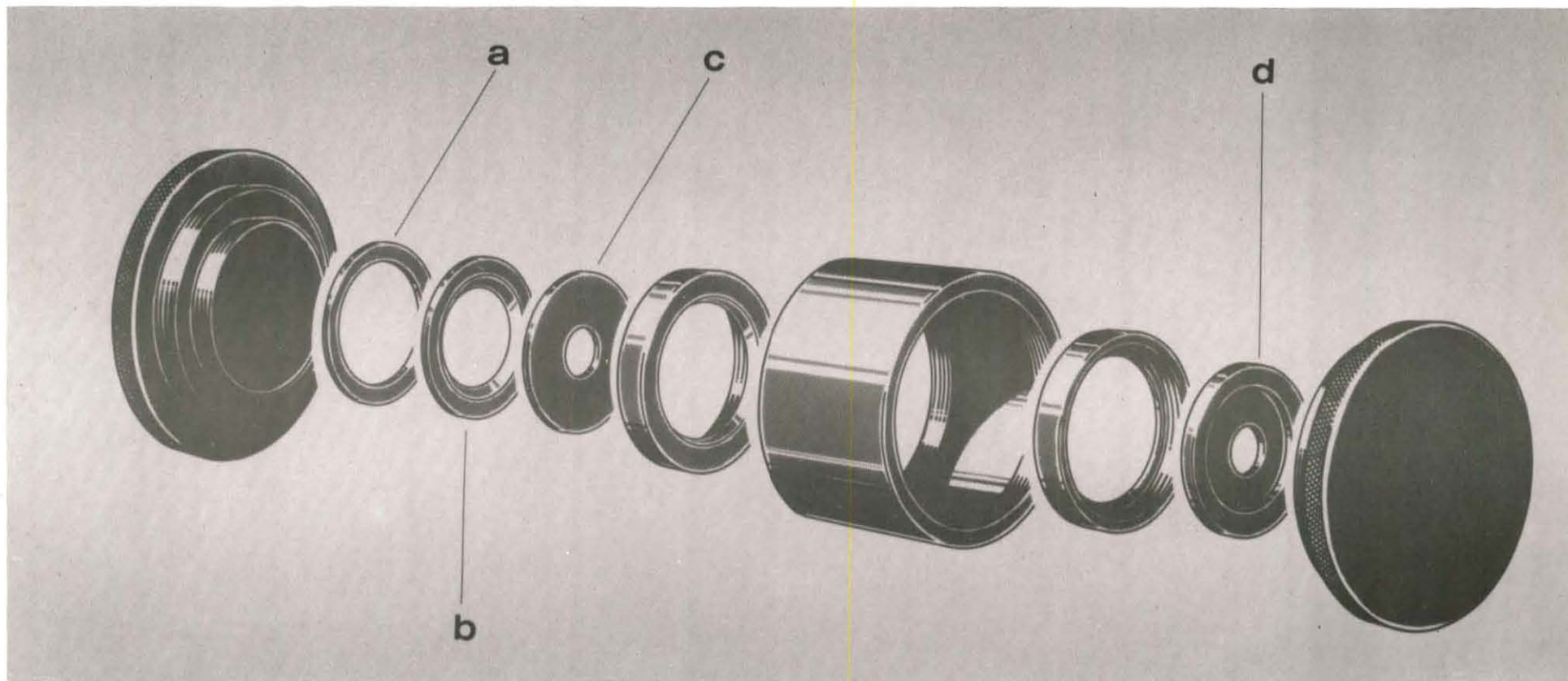

FIG. 8 - Stainless-steel container used to transfer ^{252}Cf atoms from the parent source to the prepared backing; a) is a diaphragm which was set to avoid contact between the VYNS layer and the stainless-steel cover; b) is the supporting ring shown in Fig. 7; c) is a collimating diaphragm; d) is a collimating holder for the parent source.

APPENDIX: THE 4π -SOURCE OF ^{252}Cf . -

^{252}Cf was chosen for the present measurement since there are practically no data on the ionization energy loss of fission fragments for this element, and especially due to the fact that it undergoes spontaneous fission with a fairly long lifetime ($\tau_{\alpha} = 2.2$ years and $\tau_f = 66$ years, τ_{α} and τ_f being the α -decay and fission-decay lifetimes respectively).

The ^{252}Cf source used in the present experiment was asked to fulfill the following requirements:

- i) to emit fission fragments over a solid angle of $2 \times 2\pi$, i. e. to be lodged on a very thin backing;
- ii) to have a conducting backing, so that the source could be held at the same electric potential as the walls of the ionization chamber, and then did not perturb the working conditions of the ionization chamber;
- iii) to supply about 1 fission per sec over the solid angle subtended by the silicon detectors, in order that the described electronics could deal with a suitable counting rate; the source had then to supply about 250 fissions per sec of the whole solid angle.

The source backing was made of VYNS (a polyvinylchloride acetate copolymer which can be prepared on very thin films by standard procedure⁽⁷⁾), held by a thin conducting ring (see Fig. 7). The chosen film thickness, in order that the fission fragments might lose less than 1% of their initial energy, was about 10 micrograms/cm². The superficial density of the film was measured by a method of optical reflection⁽⁷⁾.

A layer of gold of about 10 micrograms/cm² was evaporated on the VYNS film. The thickness of such layer was measured by the multiple beam interferometry method⁽⁸⁾. From the data by Lassen⁽²⁾ one can easily infer that the initial energy loss of the fission fragments in 10 micrograms/cm² of gold is practically negligible compared to the corresponding energy loss in the prepared VYNS film. The resistance of the gold layer was found to be about 100 ohms.

The ^{252}Cf was deposited on the backing by a self-transfer technique⁽⁹⁾. As is well known, this is based on the fact that, due to the local heating produced by fission fragments in a parent source, a few thousand atoms may escape together with it, and be deposited onto a proper backing. Satisfactory uniformity of the deposited ^{252}Cf layer can be achieved in this way. The isotopical purity of the prepared source, moreover, is essentially given by the one of the parent sample.

The source used for the present experiment was prepared by transferring under vacuum the requested number of atoms from the parent source to the prepared backing, using the metal container shown

in Fig. 8. The parent source had the following characteristics: 0.25 inches diameter, 0.5 micrograms ^{252}Cf (total weight), 2×10^{-4} Curie activity, i. e. 2×10^5 fissions per sec.

The activity of the prepared source was found by counting the alpha-particles emitted by the source itself, knowing that for ^{252}Cf , $\lambda_{\alpha} = \sim 30 \lambda_f$, where λ_{α} and λ_f are respectively the rates for alpha-decay and for fission of such nucleus. A daughter source supplying about 250 fissions/sec was obtained in this way within one week's exposure.

ACKNOWLEDGEMENTS.

The authors are indebted to Dr. A. Vitale for his interest and stimulating arguments, and to Prof. M. Forte for some useful discussions.

REFERENCES. -

- (1) - O. Lassen, Kgl. Danske Videnskab. Selskab, Mat. Fys. Medd. 25, 11 (1949).
- (2) - M.S. Moore and L.G. Miller, Phys. Rev. 157, 1049 (1967).
- (3) - M. Forte, Colloque International sur l'electronique nucleaire Versailles 1968.
- (4) - J. Terrel, Phys. Rev. 127, 880 (1962).
- (5) - H.W. Schmitt et al., Phys. Rev. 137, B837 (1965).
- (6) - U. Facchini, M. Forte, A. Malvicini and T. Rossini, Energia Nucleare 3, 182 (1956).
- (7) - Pate and Yaffe, Can. J. Chem. 33, 15 (1955).
- (8) - S. Tolansky, Multiple beam interferometry of surfaces and films (Clarendon Press, 1949).
- (9) - B.V. Ershler and F.S. Lapteva, Atomnaya Energiya 1, 4, 63 (1956) (Engl. Transl.: J. Nuclear Energy 4, 471 (1957)).