



**ISTITUTO NAZIONALE DI FISICA NUCLEARE**

**Sezione di Catania**

---

**INFN/AE-05/07**  
**July 18 2005**

**AN INEXPENSIVE COINCIDENCE CIRCUIT FOR  
THE PASCO GEIGER SENSORS**

Filippo Fichera<sup>2</sup>, Paola La Rocca<sup>1</sup>, Francesco Librizzi<sup>2</sup>, and Francesco Riggi<sup>1,2</sup>

<sup>1</sup>*Dipartimento di Fisica e Astronomia, Università di Catania, Via Santa Sofia 64,  
I-95123 Catania, Italy*

<sup>2</sup>*INFN-Sezione di Catania, Catania, Italy*

**Abstract**

A simple coincidence circuit was devised to carry out educational coincidence experiments involving the use of Geiger counters. The system was tested by commercially available Geiger sensors from PASCO, and is intended to be used in collaboration with high school students and teachers.

PACS.: 01.40.Ej, 29.40.-n, 96.40.-z

*Published by SIS-Pubblicazioni  
Laboratori Nazionali di Frascati*

Educational experiments involving the detection of cosmic rays at sea level by the use of simple detectors are a powerful means of introducing high-school students and teachers to the wonderful world of research in high energy physics. Recording cosmic ray intensities even by simple Geiger counters may introduce to several aspects of detection techniques and data analysis [1].

The potential of such experiments may be largely improved by the use of coincidence techniques, which allow the investigation of those events where one has the simultaneous firing of two or more detectors. While fast detectors, such as scintillators, could require the use of sophisticated electronics in the nanosecond timing range, which is beyond the scope and possibilities of self-construction, especially at the high-school level, Geiger counters provide signals in the order of microseconds, which allow to use simple AND circuits to build up a coincidence set-up.

To support a series of educational cosmic rays experiments with the involvement of high-school teams, our Institution has devised and used an inexpensive circuit for the study of coincident events from commercially available Geiger counters. The PASCO [2] Geiger sensors (Mod. SN7928) were used to test the system. Each Geiger sensor may be individually connected to a PASCO interface (for instance the Mod. 500 or 750) for read-out, control and data analysis, providing a useful ready-made system for experiments on radioactivity and cosmic ray physics. Each Geiger counter produces a TTL-like signal, of amplitude +5V and width around 120  $\mu$ s. Due to the size of such counters, the counting rate at sea level from cosmic rays is about 0.3 Hz. The circuit which was devised is able to provide a signal which is compatible with the expected input from such interfaces, making the connections very simple to handle. Actually, for the purpose of monitoring also the single count rate from detectors, the signal from one of the two Geigers may be split and sent both to one digital input of the PASCO interface and to the coincidence circuit, which in turn triggers a second digital input on the interface. Fig.1 gives a sketch of the possible connections.

The circuit is depicted in Fig.2. Two widely used IC's are used. Two sections of the 74LS123 (a dual retriggerable monostable multivibrator) are used to provide standard signals whose widths may be varied by selection of the external resistors  $R_1$  ( $R_6$ ) and capacitors  $C_8$  ( $C_{12}$ ). In our case, values of 180 k for the resistors and 2.2 nF for the capacitors gave output widths in the order of 150  $\mu$ s. The AND gate was provided by a single section of a quad 2-input CMOS 4081. In such configuration, the output signal was transported with a cable length of a few meters without problems. The circuit was tested also with battery supply (4 x AA 1.5 V); however this solution is suitable only for measurements which last only a few hours. Since quite often coincidence experiments require long runs, and the power consumption is not negligible, an alternative power solution was planned, with an external 12V power supply, and an internal circuit for stabilization, filtering and protection.

In a coincidence experiment, the rate  $R_s$  of spurious coincidences is given by

$$R_s = 2 \tau R_1 R_2$$

where  $R_1$  and  $R_2$  are the individual rates of the two detectors, and  $\tau$  is the coincidence window. For typical rates  $R_1, R_2$  of 0.3 Hz and  $\tau = 150 \mu\text{s}$ , one obtains a rate  $R_s$  of about  $2.7 \times 10^{-5} \text{ s}^{-1}$ , i.e. about one spurious coincidence every 10 hours. This is not a serious problem for the measure of the muon angular distribution, where a single muon must traverse both detectors. However one may reach this limit for more sophisticated experiments, such as the investigation of the decoherence curve, where one requires the detection coincidence rate of two individual muons as a function of the relative distance between the two Geigers.

The circuit is actually in use since several months to carry out cosmic ray experiments involving the coincidence between two Geiger sensors. The physical results of such experiments will be discussed in forthcoming notes.

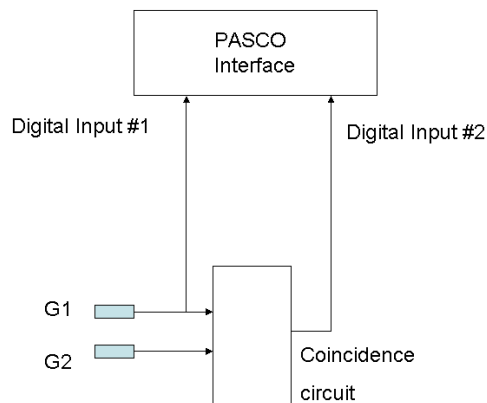

Fig. 1: Sketch of the connections to the PASCO interface.

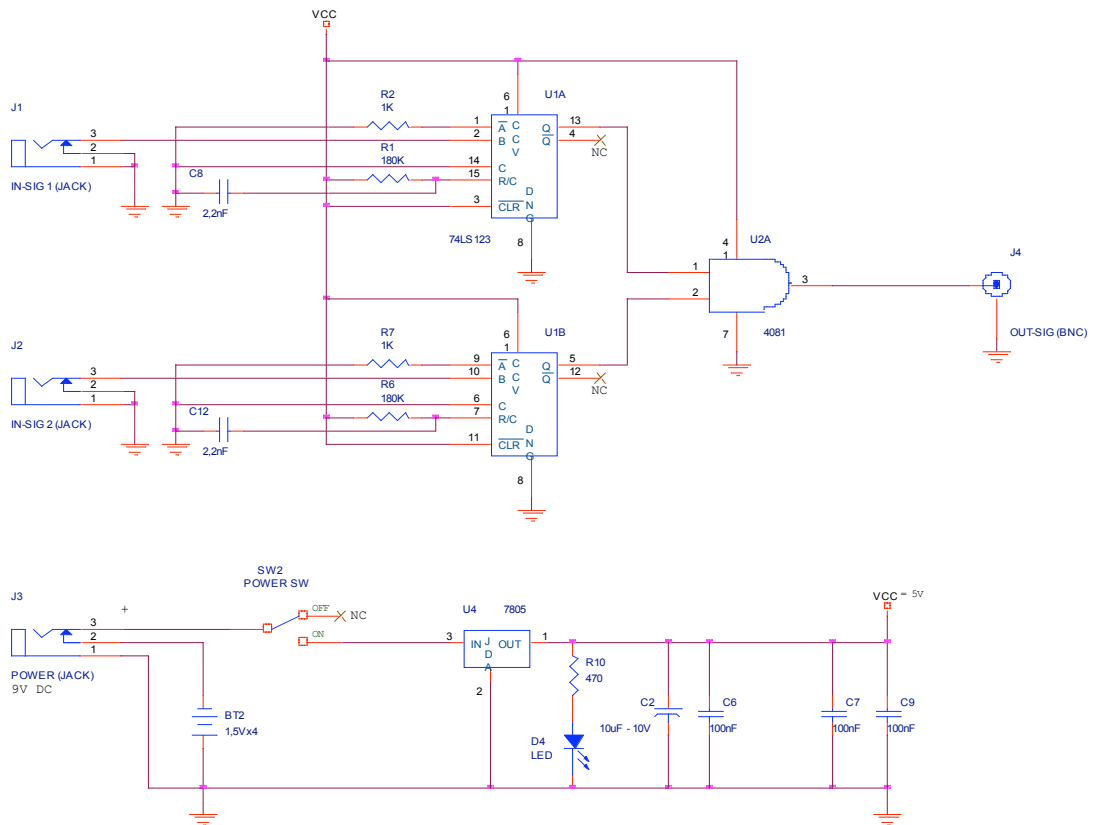

Fig.2: Lay-out of the coincidence circuit which may be used with two Geiger sensors to provide an output signal compatible with PASCO interfaces. Also shown is an optional power supply.

## REFERENCES

- [1] Famoso B, La Rocca P, and Riggi F, Physics Education **40**(2005) in press, and references therein.
- [2] PASCO Science Workshop Probeware, <http://www.pasco.com>