



ISTITUTO NAZIONALE DI FISICA NUCLEARE

Laboratori Nazionali di Frascati

INFN-23-27-LNF

25-10-2023

Manufacture of a MoO₃ coated copper made device

S. Macis^{1,2}, A. D' Elia^{2,3}, L. Mosesso¹
J.S. Rezvani⁴, B. Spataro, S. Lupi^{1,2} and A. Marcelli^{2,3}

¹*Department of Physics, Università Sapienza, P.le Aldo Moro 5, 00185 Rome, Italy*

²*INFN, Laboratori Nazionali di Frascati, Via Enrico Fermi 54, 00044, Frascati (Rome), Italy*

³*Rome International Centre for Materials Science Superstripes, Via dei Sabelli 119A, 00185 Rome, Italy*

⁴*INFN–Sezione di Roma, P.le Aldo Moro 2, Roma 00185, Italy*

⁴*Sezione Fisica, Scuola di Scienze e Tecnologie, Università di Camerino, via Madonna delle Carceri, Camerino (MC) 62032, Italy.*

Abstract

We describe the procedure to manufacture a model of a cylindrical RF cavity made in copper and coated with a 100 nm thick layer of molybdenum trioxide. The device is 100 mm long, has an internal diameter of 60 mm and an external diameter of 80 mm. The cylindrical device was carefully divided into four sections to make possible the coating on the internal curved surfaces polished to a roughness < 10 nm. The molybdenum trioxide has been deposited utilizing a thermal evaporation technique with a dedicated high vacuum chamber equipped with a high-temperature Alumina crucible working in the temperature range of 400° - 600° C.

1. Introduction

One of the most exciting areas of research and development in the rapidly advancing field of technology is the improvement of the performances of RF cavities. This technological research is primarily driven by the need to operate accelerators at higher gradients [1]. RF devices functioning at gradients exceeding 100 MV/m or higher hold great promise for the forthcoming generation of linear accelerators intended for research purposes. Moreover, they have significant potential for designing more compact and cost-effective industrial equipment, particularly in sectors like biomedical and security.

To enhance well-established RF technologies based on copper devices, our research focus shifted towards improving the properties of OFHC copper coated with Transition Metal Oxides (TMO) layers. Among these oxides, our studies were focused on MoO₃ oxide, a very hard transition metal oxide with one of the highest melting points and highest work functions. The MoO₃ coating has the potential to improve the performances of RF acceleration devices by minimizing field emission, breakdown rates, and thermal damage when subjected to high electric fields [2,3].

In order to reduce the breakdown rate (BDR), different strategies have been proposed. On one hand, there is prospect on engineering the next generation of the electron sources at higher frequencies to reduce the time pulse and thus the pulse heating. The use of non-annealed harder copper alloys (CuAg, CuCr, and CuZr) could also mitigate the surface damage induced by breakdowns. However, the relatively low work function of copper may simply trigger the breakdown. Indeed, it has been demonstrated that dark current beam loading plays a fundamental role in the degradation of Q₀. [4] A possible route to reduce the Fowler-Nordheim (FN) currents [5] consists in using coatings characterized by a high work function (WF). TMO are an interesting option to reduce the FN currents as the possible solution to other fundamental and technological issues related to physical and chemical surface processes. The WF in TMOs is correlated with the average cation oxidation state [6] so subtle deviations on the stoichiometry may tune the WF appreciably. Among TMOs, the molybdenum trioxide MoO₃, in the form of thin films grown at room temperature on polycrystalline Cu, exhibits interesting properties for coating high gradient accelerating structures [2]: (i) they exhibit amorphous orthorhombic phase (α -MoO₃), characterized by a higher WF with respect to copper; (ii) the transport properties may be tuned by varying the film thickness. While coating layers of (30 to 300) nm show metallic behaviour, thicker films behave as semiconductors or insulators.

In previous works we studied the impact of a high electric field on RF devices on coated surfaces. We tested coatings using intense, coherent THz radiation by using the ISIR Free Electron Laser (FEL) at Osaka [3,7]. With the ISIR we applied to coated and uncoated samples electric fields as high as 5 GV/m. In this research, we showed that the damage increases for increasing incidence angles with multiple shots ($>10^3$) and the fluence of 12.7 J/cm² per pulse. We estimated the increase of the temperature of the copper surface pointing out that the increase in absorption at high incidence angles may cause damage and oxidation and for incidence angles $>20^\circ$, the temperature can be higher than the melting temperature of copper, in agreement with previous reports in the optical frequency range [8,9]. We also showed for the first time the occurrence of an angular dependent reproducible damage induced by THz multiple high-intensity pulses on metallic copper surfaces, a damage explained in terms of a fast local temperature increase, neglecting electric-related effects,

e.g., discharges and/or breakdowns occurring in air due to the strong electric field applied [10]. This work also pointed out the need to characterize better the observed damage patterns and their dynamics following multiple irradiation procedures. This innovative method to test in a reliable and controlled way the damage induced on a smooth surface offers the way to test accelerating cavities and RF devices like that described in this note for a cylindrical device coated with a thin molybdenum oxide layer.

2. Experimental layout

Cylindrical cavity coating

In our study we started with a copper cylindrical device, similar to the body of a typical RF cavity, measuring 100 mm in length, with an internal diameter of 60 mm and an external diameter of 80 mm. The cavity was carefully cut into four identical sections (90° each) to facilitate the coating procedure. We have to underline here that the cutting reduces the dimension of the structure of few mm. Reassembling the device, i.e, welding the four sections together you cannot reproduce the original cylindrical shape. However, there are solutions, e.g, starting from two identical cylinders cut with different dimensions to obtain four identical parts suitable to obtain by welding a device with the precise internal and external diameters.

Prior to coating, each section underwent an accurate surface preparation procedure. Initially, surface imperfections were eliminated through polishing. Subsequently, diamond milling was employed to achieve a surface roughness < 10 nm, a critical parameter for the use of this device as cavity with high performance (Figure 1).

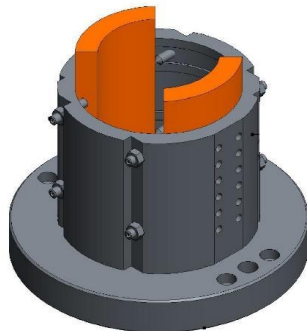

Figure 1: Left: CAD draft of the mount device used for the milling process of the copper sections. Right: Photo of one of the copper sections after the polishing and the diamond milling processes.

Polished polycrystalline Cu substrates with a nominal roughness < 25 nm were first cleaned with acetone and isopropanol sonic baths for 10 min each. Pure MoO_3 (99.999%) powder from Sigma Aldrich was used to grow the MoO_3 oxide films. Powder was heated up to 600 °C in a tungsten crucible inside the evaporation chamber with a base pressure of 10^{-5} mbar. In order to anneal the coating without oxidizing the copper substrate, a heat treatment in a low vacuum environment was performed, with a base pressure of 5×10^{-1} mbar. Our setup allowed us to reach a temperature of up to 500 °C in less than 10 minutes, with a constant heating rate of ~ 1 °C/sec. After a brief

temperature decrease, the samples were exposed to air at 200 °C to increase the amount of oxygen in the film [11]. The copper sections (with flat or curved surfaces) were loaded in the upper part of the chamber with the internal surfaces facing the crucible at the distance of ~400 mm. A mechanical shutter inside the HV chamber allows the control of the evaporation flux. The method ensured a uniform coating across the surfaces, providing a transparent metallic layer to the copper substrate, with a WF higher than that of the copper surface. [6] The chamber has been tested it has reached a limit vacuum of $8 \cdot 10^{-6}$ mbar and has been tested at a maximum temperature of 600° C.

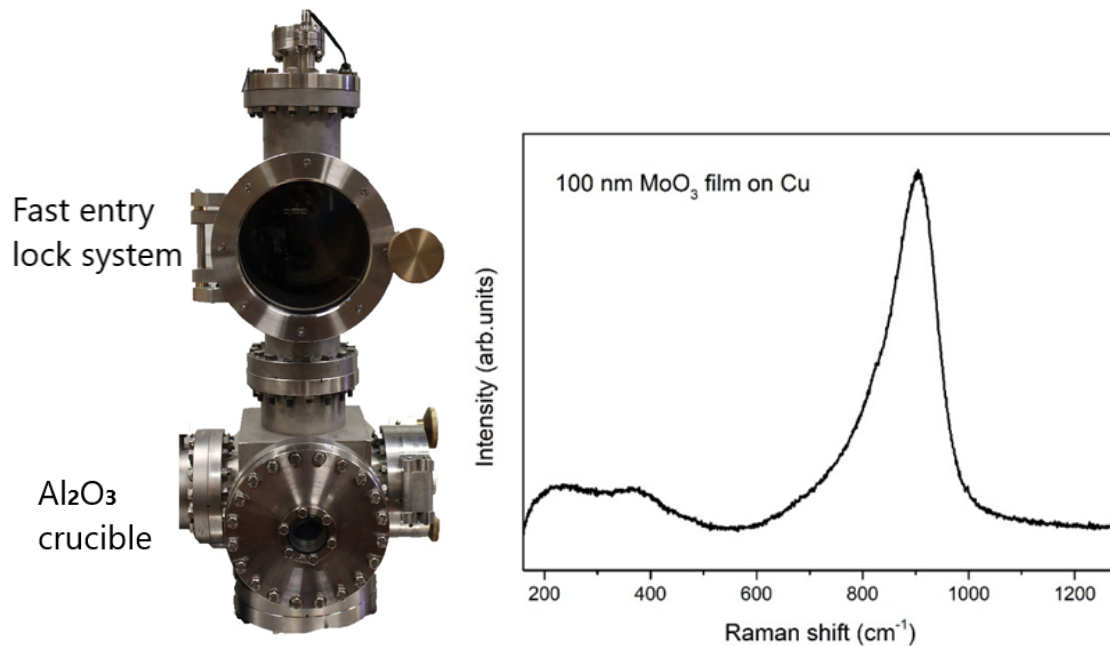

Figure 2. Left: Photo of the system used to evaporate MoO₃ layers. The HV deposition chamber in the bottom hosts the solid phase Al₂O₃-crucible, while in the top are mounted the substrates to be evaporated. Right: Typical Raman spectrum of a MoO₃ film (100 nm thick) deposited on a copper substrate.

In order to check the quality of the evaporated films, sections were characterized by Raman spectroscopy, an easy and reliable technique to identify the chemical composition of a surface. Measures were performed with a green laser (532 nm) with a 20x magnification objective and a 5 μm diameter spot on several point of (flat and curved) surfaces. In Figure 2 (right panel) is showed the Raman spectra of the MoO₃ deposited on one of the copper sections. The spectra with a wide Raman peak at about 800 cm⁻¹ is characteristic of a disordered phase of the MoO₃. Following the successful application of the MoO₃ coating, the four sections were reassembled. The Tungsten Inert Gas (TIG) welding procedure was employed to fuse the edges of the sections together, a process crucial for maintaining the device's structural integrity. During the assembly procedure, the temperature control was of paramount importance to prevent any potential damage to the device induced by temperature. Indeed, we evaporated the oxide at ~600 °C, but evaporations of MoO₃ can start also at temperatures between 500° to 550° C. As a consequence, to avoid the evaporation of the oxide film deposited on the internal surface of the device and relevant additional annealing, the entire welding process has been performed at a much lower temperature. As shown in Figure 3 a type K thermocouple was attached to the copper sections to provide real-time temperature feedback. The welding process was executed while ensuring the copper device's temperature remained below 150° C.

As clear from the graph in Figure 4, where it is shown the temperature evolution during the welding process, the temperature measured near the welded sections rose up to 148° C and was kept around that value during the entire procedure, which lasted around 20 s.

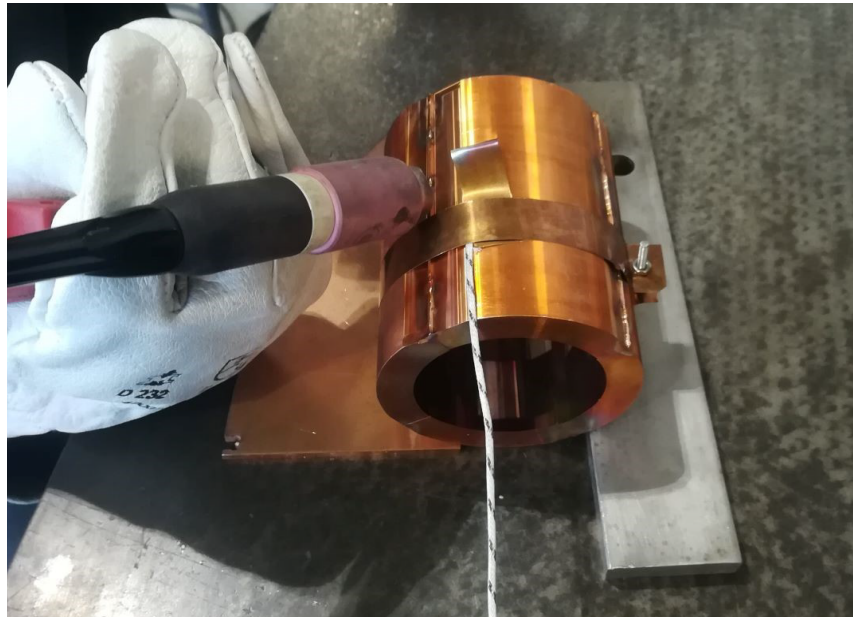

Figure 3. Photo showing the TIG welding process of the copper coated sections realized with the support of Co.Me.B.. A thermocouple near the welded part monitors the temperature increase during the welding process.

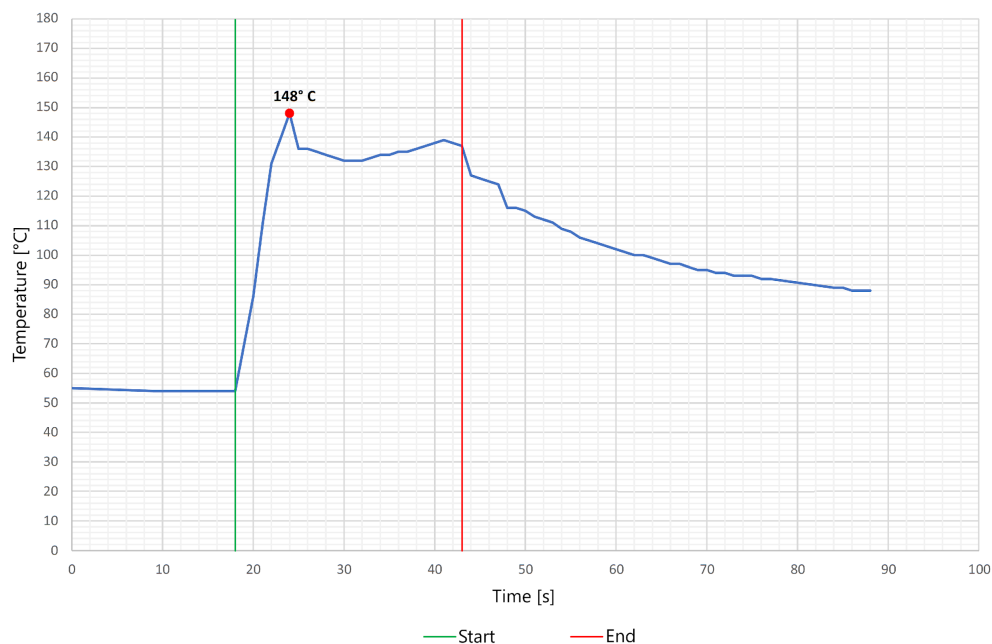

Figure 4. Plot showing the temperature evolution of the welding process measured in the location showed in Figure 3.

All of four sections were successfully welded together to obtain the original cylindrical structure with the internal surface coated by the thin layer of molybdenum oxide.

The two images in Figure 5 clearly show the assembled device where it is possible to recognize the welded regions on the external surface of the copper device and the mirror-like finish of the internal surfaces due to the transparent oxide films that was preserved during the welding procedure. It is clear that this device is not a cavity, but the entire procedure, from the evaporation to the welding

has been tested and the success of the different steps guarantees the feasibility of the procedure to assembly a closed copper-based RF cavity with internal surfaces coated by MoO₃.

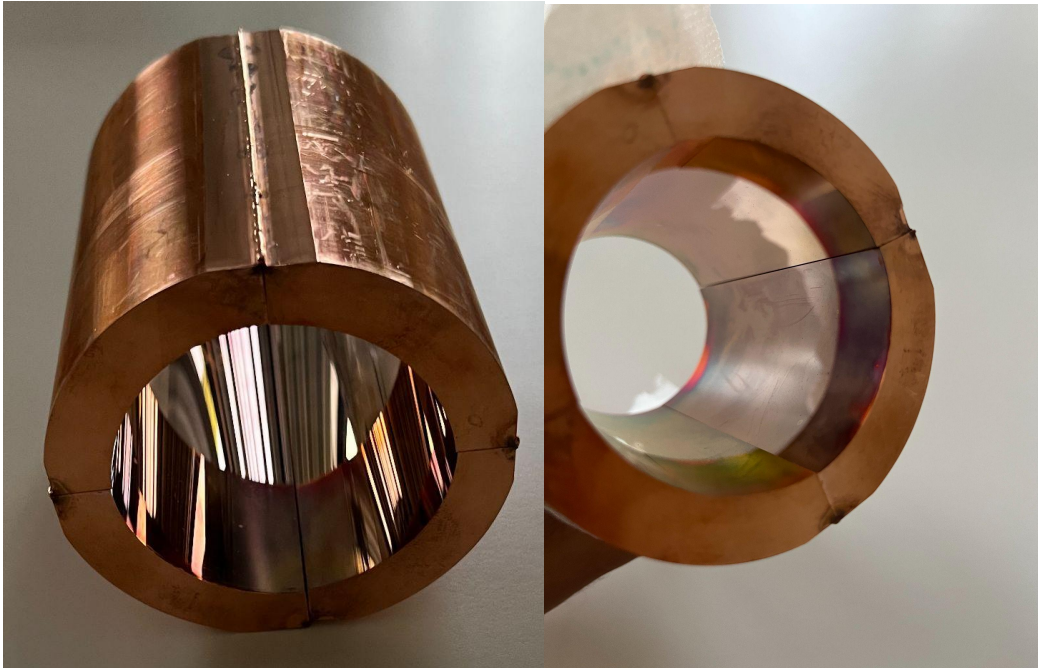

Figure 5. Two photographs of the cylindrical device 100 mm long after the welding procedure.

Conclusions

In this report we describe the procedure that allowed to manufacture a model of a cylindrical RF cavity made in copper coated with a thin layer of transparent metallic molybdenum trioxide film ~ 100 nm thick. The device showed in Fig. 5 is 100 mm long and has an internal diameter of 60 mm. To allow the evaporation the device was cut into four sections later polished to a roughness < 10 nm. The molybdenum trioxide has been deposited on the four curved sections by thermal evaporation using a dedicated HV chamber and Alumina crucible working at the temperature greater than 450°C .

The described methodology and the mirror-like images of the coatings on the internal surface of the copper device, i.e., with a roughness higher of the copper surface, show that mechanical and thermal processes can be combined to manufacture a coated copper cavity in order to enhance the performance of a foreseen RF device. Analysis recently published [12] demonstrated the potential effectiveness of molybdenum thin films, which only slightly affects the accelerating cavity quality factor, with a very low sensitivity to thickness and resistivity inhomogeneities.

This research demonstrates that the combination of accurate substrate polishing, controlled coating deposition, and careful mechanical cut and welding, together with a stringent temperature control may guarantee the robustness and efficacy of the entire procedure.

Acknowledgments

We acknowledge the *Ministero degli affari esteri e della Cooperazione Internazionale* for support, within the framework of the Italian-Chinese collaborative research in 3D graphene and Italian-

Japanese bilateral project *Spettroscopia THz lineare, non lineare e risolta in tempo con sorgenti di radiazione di ultima generazione*.

We acknowledge Ivan Davoli of Tor Vergata University for the evaporation setup. We also acknowledge the Osaka University for providing beamtime at the ISIR facility and Prof. Akinori Irizawa for the support during the experimental runs. A special thanks is due to Co.Me.B. for the setup and test of the welding procedure.

References

- [1] R.B. Palmer, Acceleration theorems, AIP Conference Proceedings 335, 90–100 (2008) <https://doi.org/10.1063/1.48253>.
- [2] S. Macis, C. Aramo, C. Bonavolontà, G. Cibin, A. D’Elia, I. Davoli, M. De Lucia, M. Lucci, S. Lupi, M. Miliucci, A. Notargiacomo, C. Ottaviani, C. Quaresima, M. Scarselli, J. Scifo, M. Valentino, P. De Padova, and A. Marcelli, MoO₃ films grown on polycrystalline Cu: Morphological, structural, and electronic properties, J. Vacuum Science & Technology A 37(2), 021513 (2019)
- [3] S. Macis, L. Tomarchio, S. Tofani, S.J. Rezvani, L. Faillace, S. Lupi, A. Irizawa, A. Marcelli, Angular Dependence of Copper Surface Damage Induced by an Intense Coherent THz Radiation Beam. Condens. Matter 5, 16 (2020)
- [4] Cahill, A.D.; Rosenzweig, V.A.; Dolgashev, V.A.; Li, Z.; Tantawi, S.G.; Weathersby, S. rf losses in high gradient cryogenic copper cavity. Phys. Rev. Accel. Beams 2018, 21, 061301. <https://doi.org/10.1103/PhysRevAccelBeams.21.061301> 231
- [5] Fowler, R.H.; Nordheim, L. Electron Emission in Intense Electric Fields. Proc. R. Soc. A 1928, 119, 173–181. 232, <https://www.jstor.org/stable/95023>
- [6] Greiner, M.T.; Chai, L.; Helander, M.G.; Tang, W.-M.; Lu, Z.-H. Transition Metal Oxide Work Functions: The Influence of Cation Oxidation State and Oxygen Vacancies. Adv. Funct. Mater. 2012, 22, 4557–4568. <https://doi.org/10.1002/adfm.201200615> 241
- [7] A. Irizawa, S. Suga, T. Nagashima, A. Higashiya, M. Hashida and, S. Sakabe, Laser-induced fine structures on silicon exposed to THz-FEL. Applied Physics Letters, 111, 251602 (2017)
- [8] A.Y. Vorobyev and C. Guo, Reflection of femtosecond laser light in multipulse ablation of metals. J. Appl. Phys. 110, 043102 (2011).
- [9] Y. Miyasaka, M. Hashida, T. Nishii, S. Inoue, S. Sakabe, Derivation of effective penetration depth of femtosecond laser pulses in metal from ablation rate dependence on laser fluence, incidence angle, and polarization. Appl. Phys. Lett. 106, 013101 (2015).
- [10] A. Grudiev, S. Calatroni, W. Wuensch, New local field quantity describing the high gradient limit of accelerating structures. Phys. Rev. Spec. Top. Accel. Beams 12, 102001 (2009).
- [11] S. Macis, Deposition and Characterization of Thin MoO₃ Films on Cu for Technological Applications. Ph.D. Thesis, Roma Tor Vergata University, Roma, Italy, 2019.
- [12] P. Vidal García, S. Sarti, M. Carillo, L. Giuliano, A. Marcelli, B. Spataro, A. Alimenti, K. Torokhtii, E. Silva, N. Pompeo, Effect of Molybdenum Coatings on the Accelerating Cavity Quality Factor: A Numerical Study, Instruments 7, 33 (2023); <https://doi.org/10.3390/instruments7040033>